

### 1. PRODUCT

**16 OZ. 473ML GLASS BOTTLE - 2.90 x 6.88 Long**

### 2. PRODUCT CAPACITY

**28 PER COLUMN - 72", 32 PER COLUMN - 79"**

### 3. SET UP GUIDE UNIVENDOR-2

Product	CAM POSITION	BACK SPACER	GAGE BAR	Sold out Lever	SIDE SPACER	GAGE BAR CLIP	
						Part No.	Position
GLASS 16 OZ.	2	6	1	389242 SHORT	NONE	1066104	1
						1066112	2

**Note:** To properly vend 16 Oz. Glass. The Univendor-2 must have the columns setup correctly.

### 4. GAGE BAR CLIP SET UP.

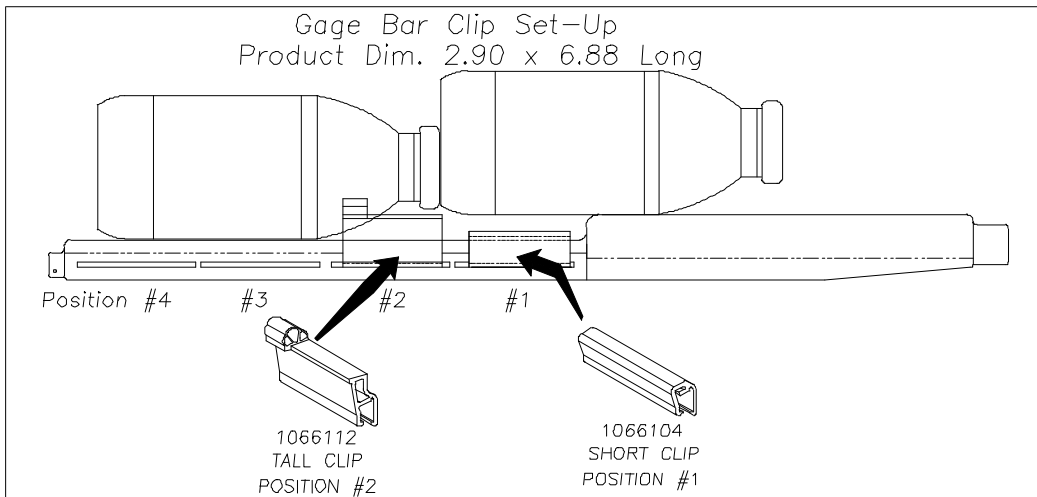

### 5. SET UP GUIDE.

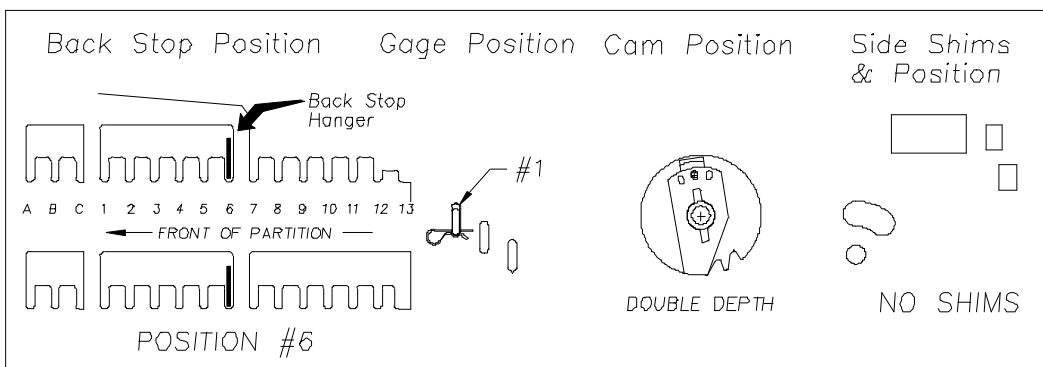

### 6. SOLD-OUT LEVER TO BE SHORT STYLE WITH FRONT SPACER. SPRING TO BE LOCATED ON THE RIGHT SIDE (LOW PRESSURE SETTING).