

10/29/97

1. PRODUCT

10 OZ. NR GLASS - 2.57 x 5.80 Long

2. PRODUCT CAPACITY

48 PER COLUMN - 72", 57 PER COLUMN - 79"

3. SET UP GUIDE UNIVENDOR-2

Product	CAM POSITION	BACK SPACER	GAGE BAR	Sold out Lever	SIDE	GAGE BAR CLIP	
					SPACER	Part No.	Position
10 oz NR GLASS	3	13	2	389242 SHORT	1060686	1066104	1 & 2

Note: To properly vend 10oz. NR Glass. The Univendor-2 must have the columns setup correctly.

4. GAGE BAR CLIP SET UP.

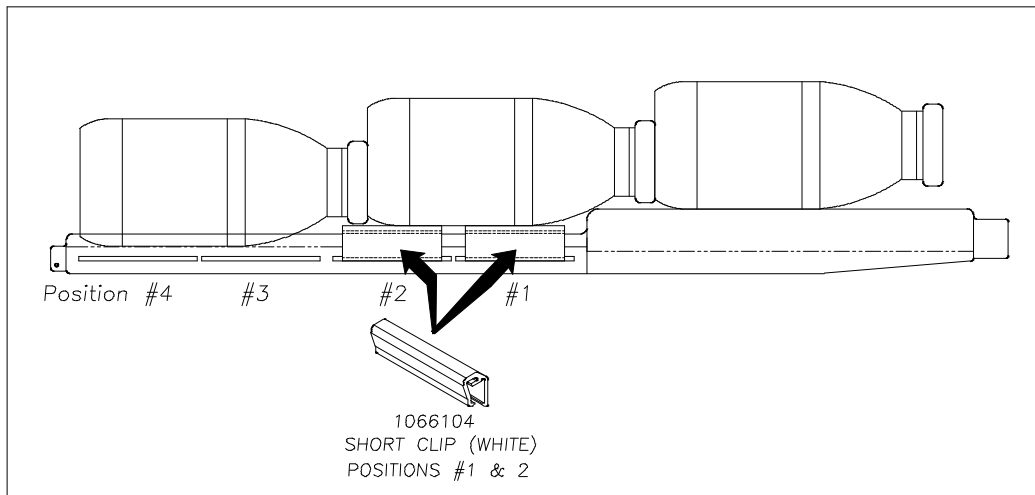

5. SET UP GUIDE.

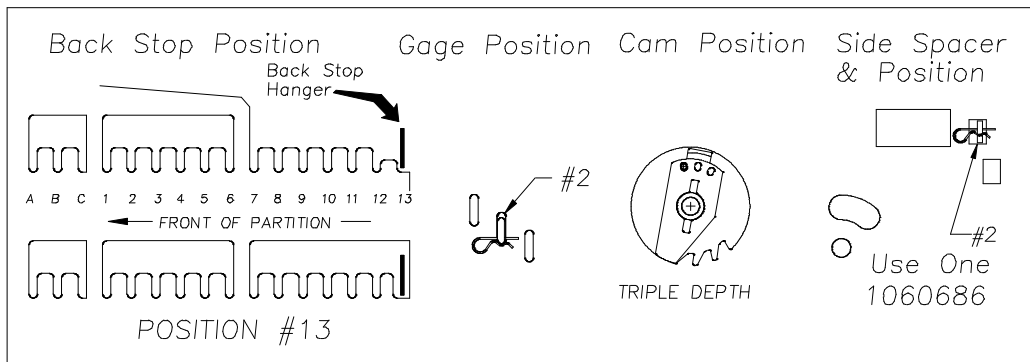

**6. SOLD-OUT LEVER TO BE SHORT STYLE WITH FRONT SPACER.
SPRING TO BE LOCATED ON THE RIGHT SIDE (LOW PRESSURE SETTING).**

6. FOR OTHER PRODUCT SET UP GUIDES CONTACT THE VENDO COMPANY.

TEL: (209) 439-1770 FAX: (209) 439-2083.