

**CONLUX**

**\$1 BILL VALIDATOR**

# **NB2-10** SERIES

## **Service Manual**



### **Contents**

Warranty .....	2
1. General Specifications .....	3
2. Quick Model Reference Chart for NB2-10 Series .....	4
3. Operation Warning .....	5
4. How to Use .....	6
5. Structure and Movement .....	8
6. Signals and Timing Charts .....	11
7. Signals of Connector and Wiring Diagram .....	14
8. Disassembly and Assembly Point .....	16
9. Cleaning .....	19
10. Inspection .....	19
11. Trouble-shooting .....	20
12. Exploded View and Parts List .....	24
13. External Measurements Diagrams .....	34

**CONLUX USA CORPORATION**

- \* The NB2-10 series has various types, differentiated according to application and location of use.
- \* When a \$1 bill is inserted with Black side up and lengthwise, 1 direction (Insert from the left side for the portrait) into the Bill insertion opening the bill is automatically drawn in and discriminated.
- \* If the bill is authentic, it will be automatically accepted and stacked; if judged to be counterfeit it will be returned. Stacker Capacity is 200 and 400 bills.

# Warranty

CONLUX USA CORPORATION warrants all new equipment sold by it to be free from defective material and workmanship. Conlux will repair or replace (at its option) any part of the equipment which proves to be defective in materials or factory workmanship within a period of twelve (12) months from the date of manufacture. In addition, printed circuit board assemblies will be warranted for a period of thirty-six (36) months from the date of manufacture of the equipment containing the printed circuit board.

Other conditions applying to this warranty are as follows:

## CONDITIONS

1. This warranty will not apply to any equipment which has been, in Conlux's opinion. Subject to: accident, abuse, misuse, neglect, improper installation, or improper maintenance or repair by unauthorized service personnel.
2. Conlux will not be responsible for any expense incurred by the purchaser incidental to the repair or replacement of equipment covered by this warranty.
3. Freight charges to send the equipment to Conlux or an Independent Authorized Service Center for warranty service will be the responsibility of the purchaser.
4. This warranty is in lieu of all other warranties oral or written, expressed or implied, including without limitation, warranties of merchantability, warranties of fitness of purpose, and all other obligations or liabilities on Conlux. Conlux neither assumes nor authorizes any person to assume for it, any other obligation or liability in connection with the sale thereof. No other obligation or liability is assumed, nor is any person authorized to make any other liability not strictly in accordance with this warranty policy.
5. Liability to Conlux USA and its independent authorized service center is limited to the repair or replacement, at their option, of defective parts and does not include incidental and consequential damages.

**CONLUX USA CORPORATION**  
9334 Highway BB  
Hillsboro, Missouri 63050

## 1. GENERAL SPECIFICATIONS

## 1. GENERAL SPECIFICATIONS

Acceptable currency	U.S. \$1 Bill
Acceptance Rate	more than 90%
Cycle duration	approx. 5.1 sec. (up to vend signal risen)
Bill insertion & return opening	one
Direction for inserting bills	black side up lengthwise, 1 direction (Insert from the left side for the portrait)
Method and condition for validation	
Shape judgement	Capability (Yes)
Graphics judgement	Capability (Yes)
Validation method	Combined by optic and magnetic
Prevention from Pull-Out	Capability (by lever system)
Power source	AC117V $\pm$ 10V, 60Hz
Temperature Range	+14°F ~ +122°F (-10°C ~ 50°C)
Weight	
200-bills stacker Main body	approx. 2.4kgs
400-bills stacker Main body	approx. 2.5kgs
Rated electricity consumption	Less than 15W during stand-by 20W up to 40W on running (When full)

**Additional Specifications**

## ☆When a bill is found authentic:

- If the inserted bill is judged to be a U.S. \$1 bill, a "Vend" signal is sent out.
- If the inserted bill is judged to be a U.S. \$1 bill, a "Counter" signal is sent out.

## ☆When a bill is not found authentic:

The following bills are ejected automatically from the insertion port after they have been inserted.

- If less than 146mm or more than 166mm lengthwise.
- If the magnetization pattern is not clear.

## ☆When inserted bill is not accepted:

Bills will not be accepted in the following conditions:

- 1) Power cut-off occurs.
- 2) "Inhibit" signal is sent out.

## 2. QUICK MODEL REFERENCE CHART FOR NB2-10 SERIES

There are the following model names. Please choose the one which you require.

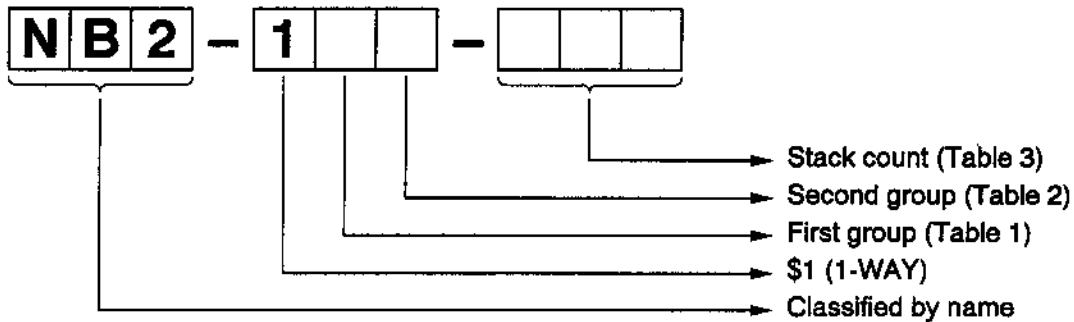

Table 1

Sign	Decal (1) Decal (2)	
	Yes	None
0		○
5	○	

Table 2

Sign	Mounting plate Decal	
	Yes	None
A		○
L	○	

Table 3

Symbol	Stacker capacity
200	200
400	400

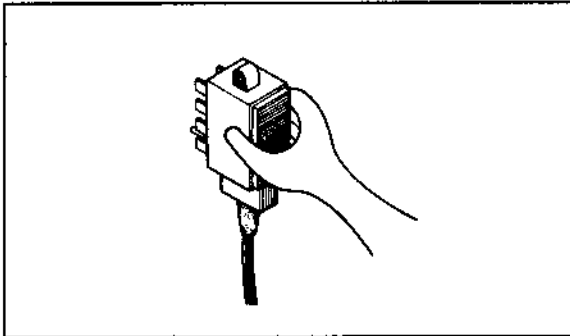
**3. OPERATION WARNING****3. OPERATION WARNING****ELECTRIC POWER SOURCE**

Use at AC 117V  $\pm$  10V. 60Hz

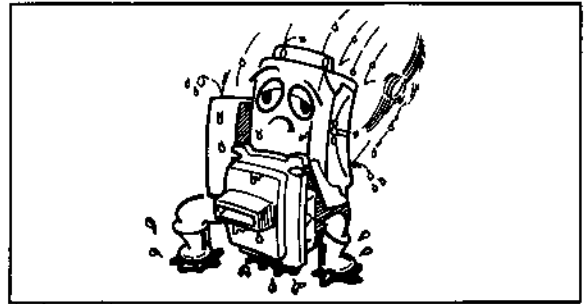
**KEEP FREE FROM DIRT AND RAIN-WATER**

Exposure to dirt and rain will cause breakdown.

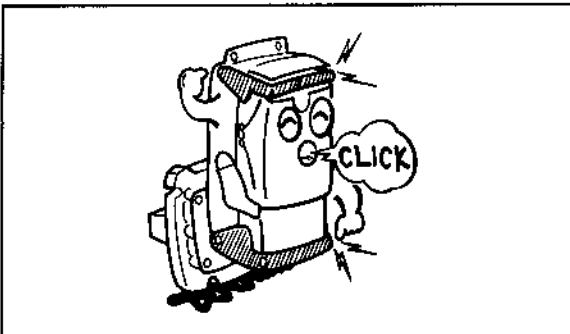
**LATCH ENGAGEMENT**

Push in the stacker firmly until it latches.

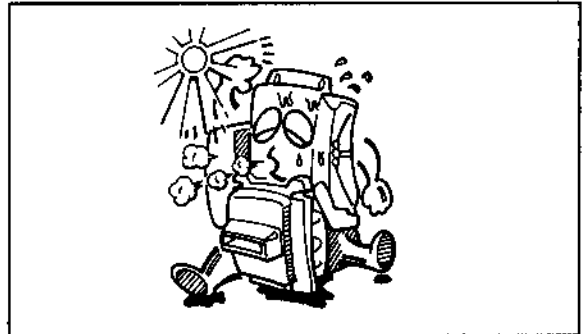
**STORAGE**

Do not place where exposed to extremes of heat, humidity, and dust.

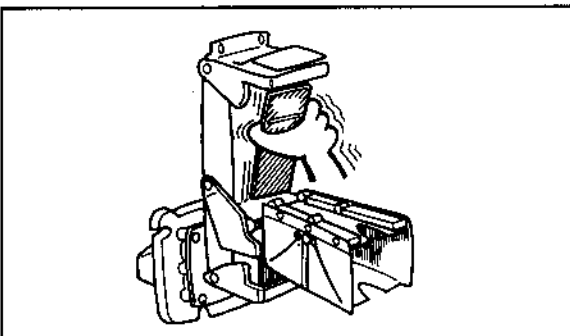
**DO NOT PULL OUT LIFT BASE**

Please refrain from moving or pulling by hand.

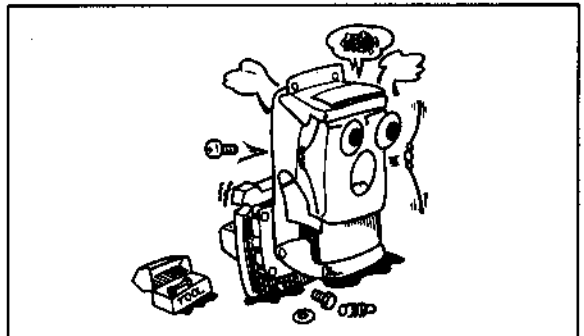
**DO NOT TAKE APART**

Taking apart will result in breakdown and we will be unable to guarantee its performance, so refrain from taking apart.

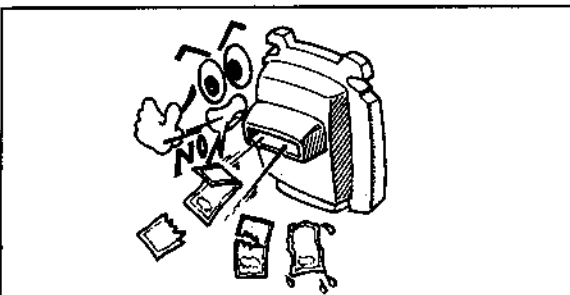
**BILLS USED**

Be careful with wet, wrinkled and torn bills. Their use leads to jamming.

**4. HOW TO USE**  
**4-1 INSTALLATION AND CONNECTION**  
**4-2 INSERTING BILLS**  
**4-3 HOW TO WITHDRAW \$1 BILL**

**4. HOW TO USE**

**4-1 INSTALLATION AND CONNECTION**

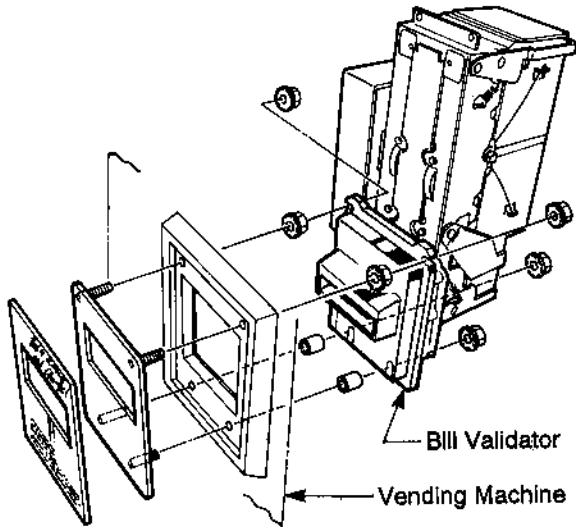

After installing this unit in an automatic vending machine, connect the connectors. Switch on the unit after connecting the power supply (AC 117V).

**4-2 INSERTING BILLS**

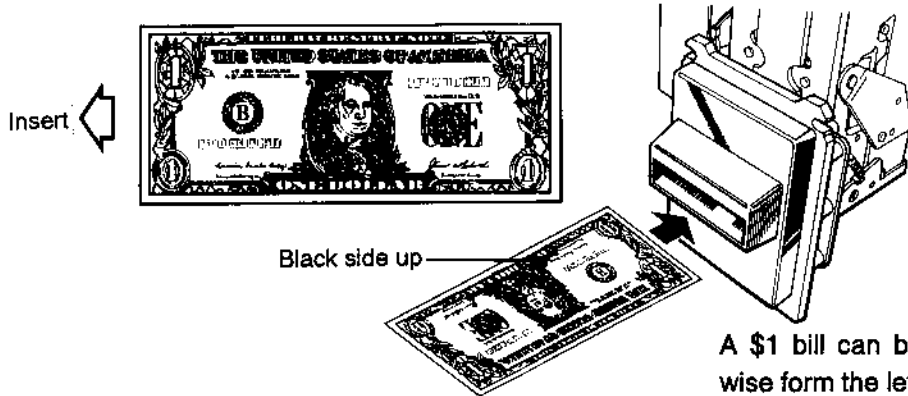

A \$1 bill can be inserted black side up length wise from the left side for the portrait.

**4-3 HOW TO WITHDRAW \$1 BILL**

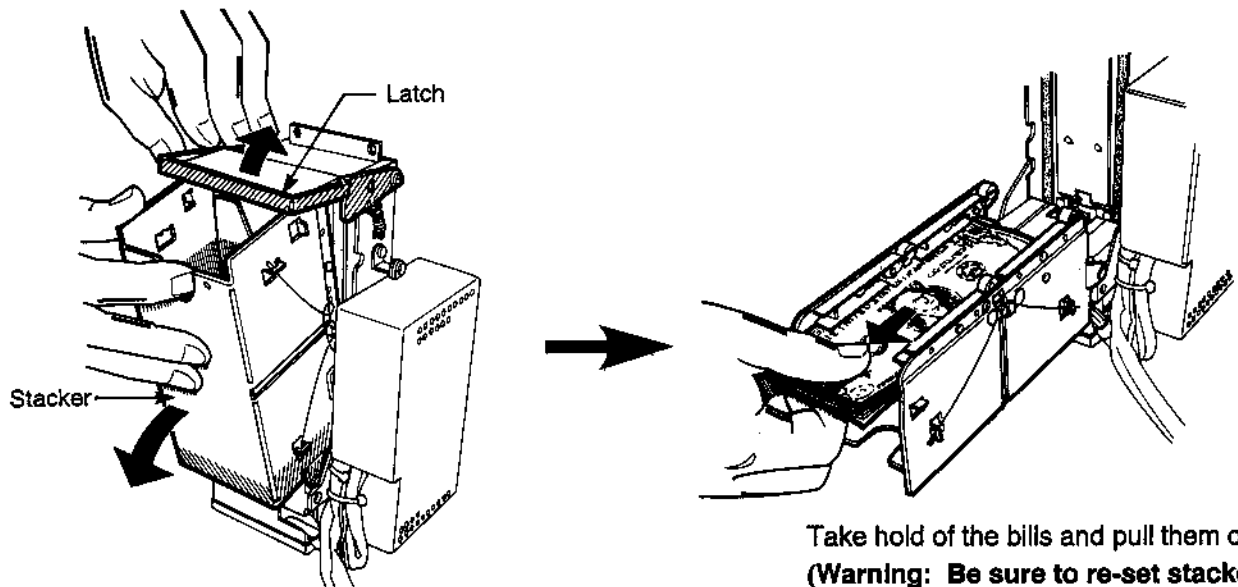

Push up the latch and pull down the stacker.

Take hold of the bills and pull them out.  
**(Warning: Be sure to re-set stacker to original position.)**

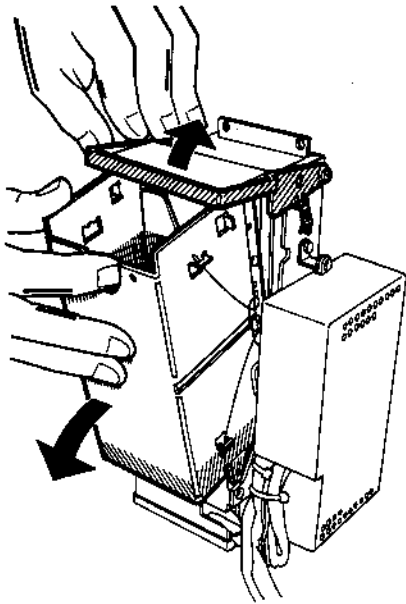
**4-4 INSPECTION: If Authentic \$1 bill will not Accept or Is Rejected after Insertion**

Push up the latch and pull down the stacker.  
If full of bills, withdraw them.  
Remove any bills or foreign matter clogging the stacker.

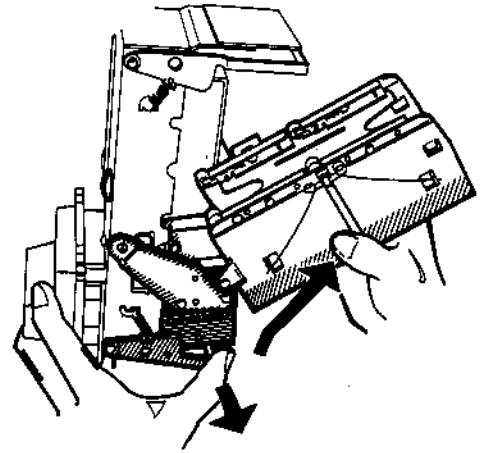

Press down the latch and pull up the stacker.

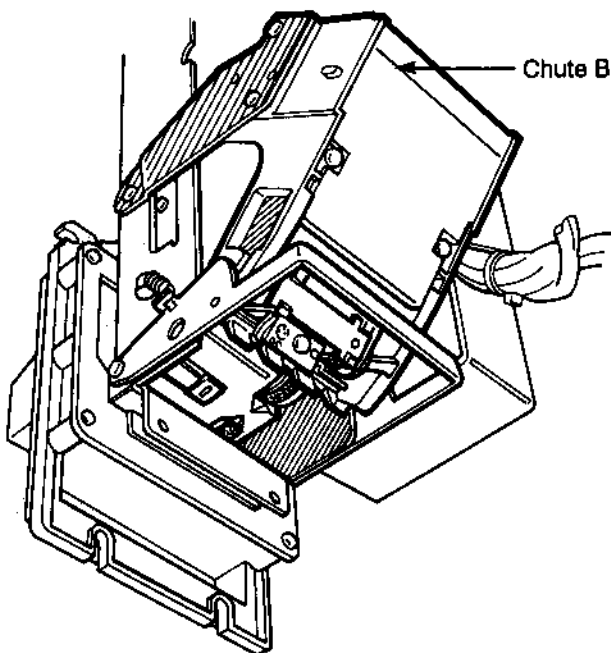

Remove any bills or foreign matter clogging the stacker.

Cut the power off and turn it on again.

**(Warning: Be sure to return stacker to original position.)**

If Authentic \$1 bill is still not received:

- \* Is the stacker and/or chute B separated from machine body? Reattach them properly using the latch.
- \* Are the photo-sensors and magnetic head dirty? Clean them.
- \* Is the "Full" signal being output? Withdraw \$1 bills.
- \* Is the "Inhibit" signal being input? Inspect the vending machine.

## 5. STRUCTURE AND MOVEMENT

## 5-1 MODULE AND COMPONENT LOCATION

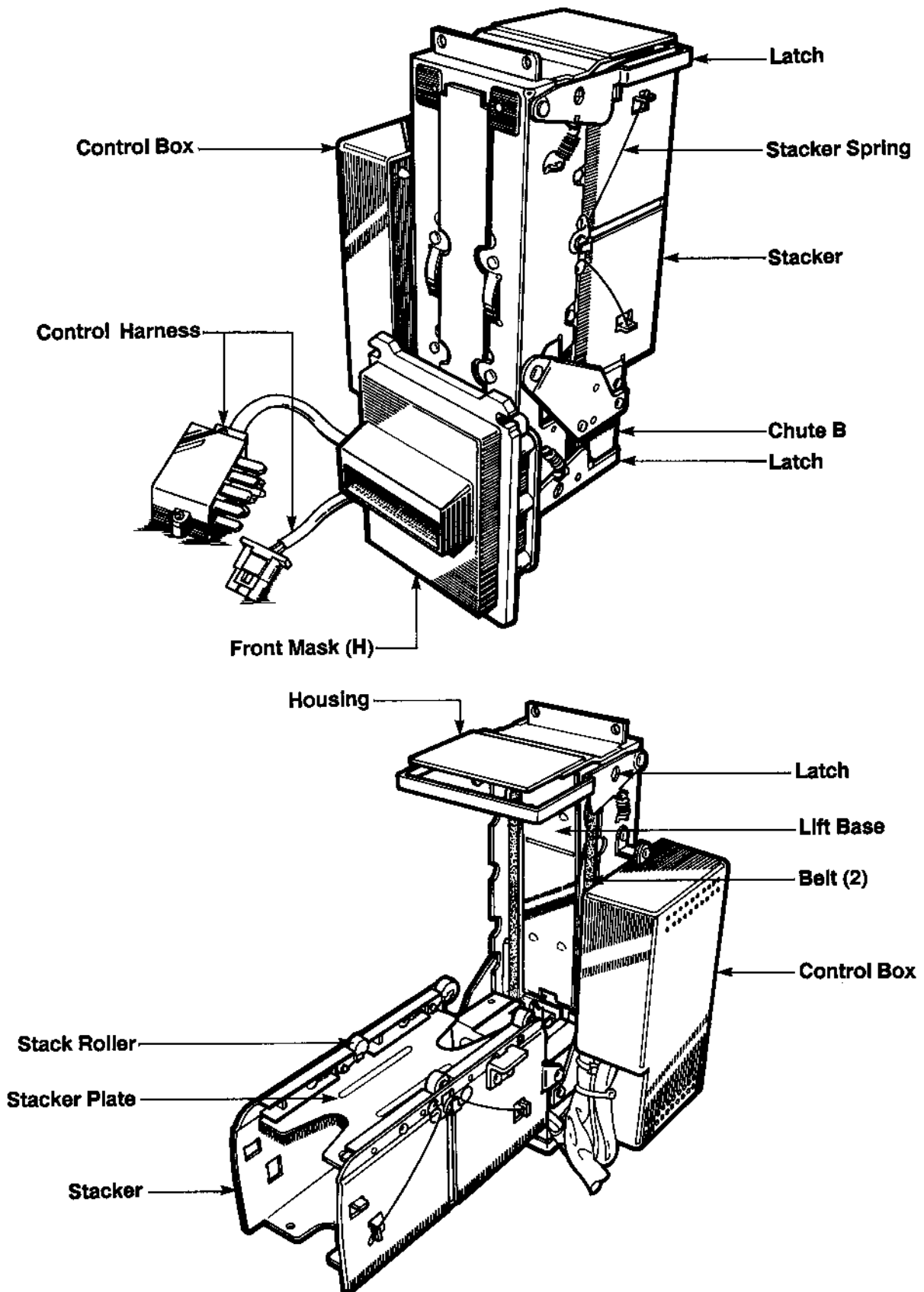



**5-2 PASSAGE OF BILL AND EQUIPMENT OPERATION**

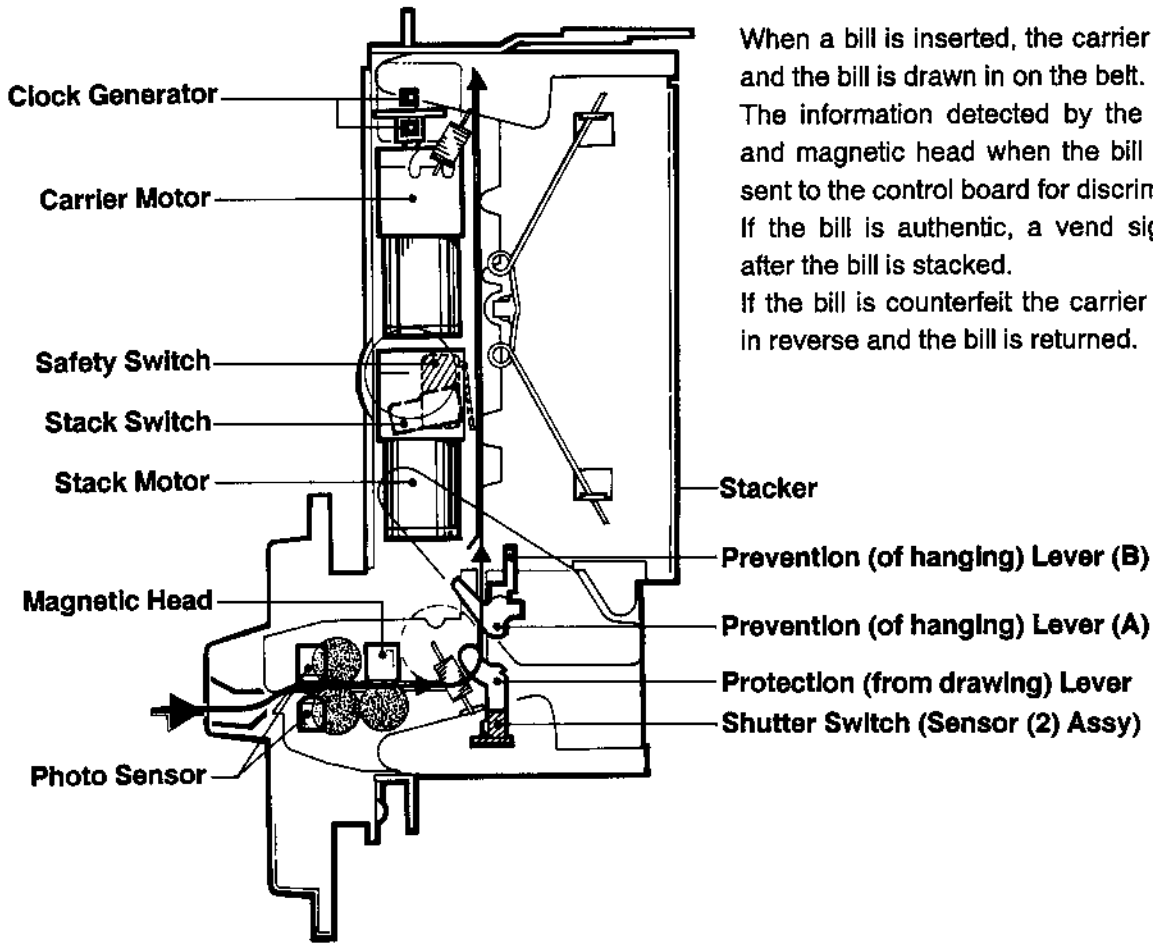

When a bill is inserted, the carrier motor rotates and the bill is drawn in on the belt. The information detected by the photo sensor and magnetic head when the bill is drawn in is sent to the control board for discrimination. If the bill is authentic, a vend signal is output after the bill is stacked. If the bill is counterfeit the carrier motor rotates in reverse and the bill is returned.

**5-3 STACKER OPERATION**

When the stack motor rotates, the lift base is pressed by the lift lever and the bill is stacked between the stacker plate and stack guide.

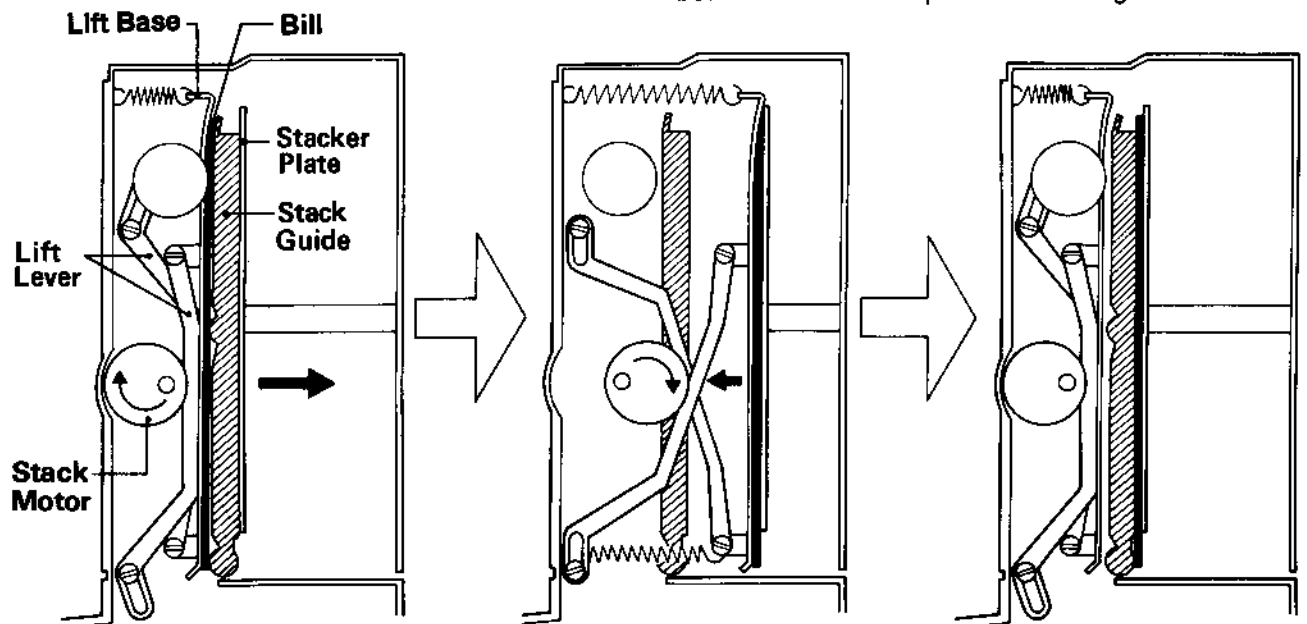

**5-4 SEQUENTIAL FLOW DIAGRAM**

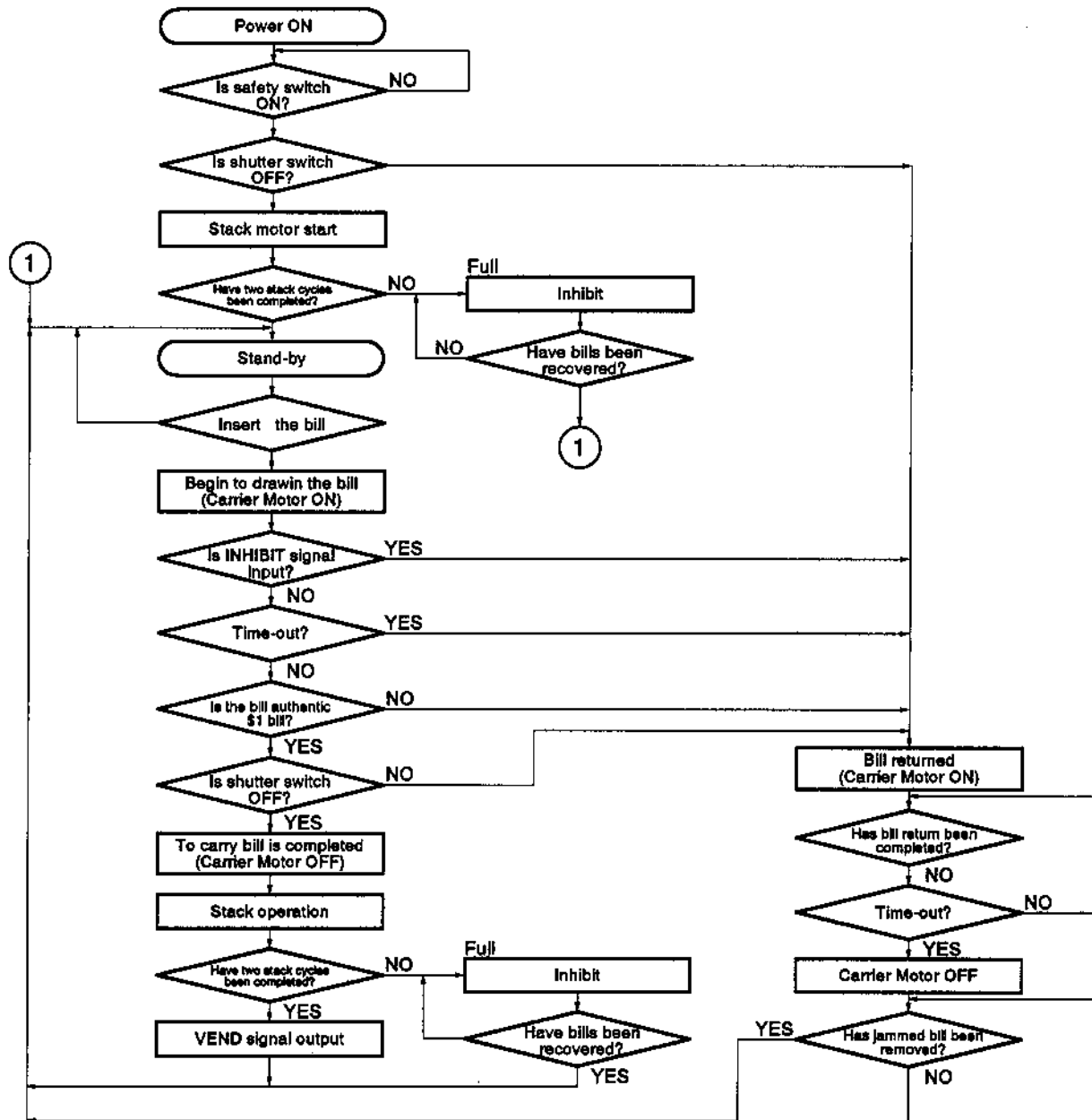

**5-5 INPUT/OUTPUT SIGNAL CONDITION (seen from Control Board)**

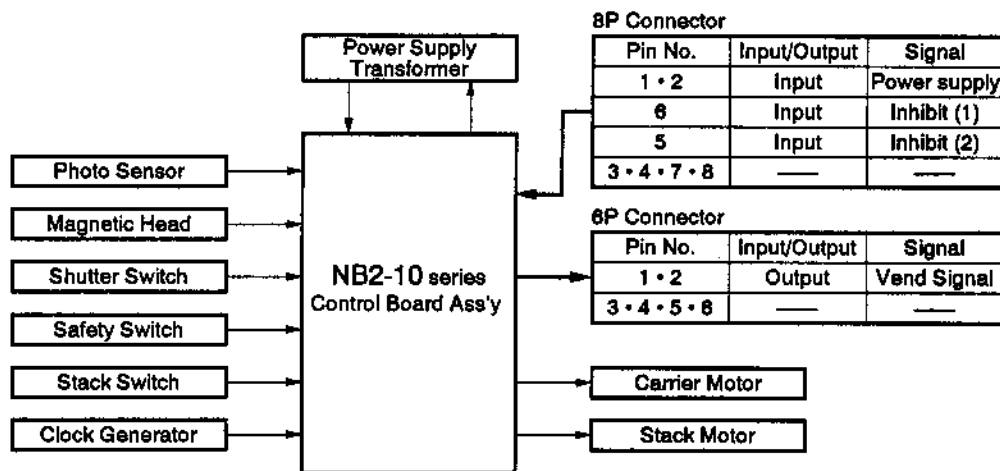

## 6. SIGNALS AND TIMING CHARTS

6-1 8P CONNECTOR

6-2 6P CONNECTOR

6-3 9P CONNECTOR (Option)

NB2-10series

① 91-3

11

## 6. SIGNALS AND TIMING CHARTS

### 6-1 8P CONNECTOR

Pin #	Designation of signals	Input/Output	Conditions
1, 2	Power Source	Input	Usually AC 117 V $\pm$ 10 V supplying 60 Hz
6	"Inhibit" Signal (1)	Input	Usually supply power is the #1 pin power source of the 8 pin connector. Signal should be cut off during "Inhibit".
5	"Inhibit" Signal (2)	Input	Usually cut off. During "Inhibit" power is supply by the #2 pin power source of the 8 pin connector.
3, 4, 7, 8	NC	—	—

### 6-2 6P CONNECTOR

Pin #	Designation of signals	Input/Output	Conditions
1, 2	"Vend" Signal	Output	When a signal is sent, the relays make contact for approx. 150 msec.
3, 4, 5, 6	NC	—	—

### 6-3 9P CONNECTOR (Option)

Pin #	Designation of signals	Input/Output	Conditions
1,4	Power Source	Output	Supplies a constant DC24V
3	Counter Signal	Output	Sends minus 24VDC from the power supply for 150 msec when an authentic bill signal is sent.
6	Full Signal	Output	Sends minus 24VDC from the power supply when the stacker is full.
2,5,7, 8,9	NC	—	—

6-4 INPUT/OUTPUT CIRCUIT

(1) Counter Signal and Full Signal Terminal

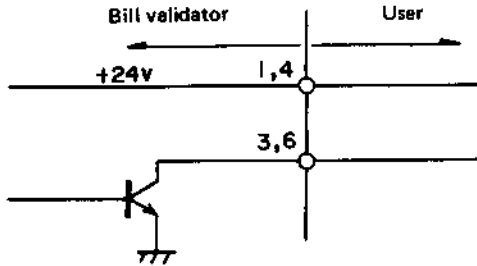

Example

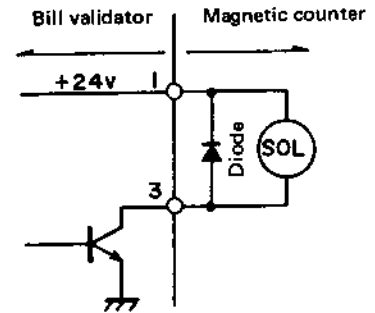

Caution:

Please insert a diode to prevent damage to transistors by a counter electromotive force when attachments such as the magnetic counter are made (see right diagram).

6-5 TIMING CHART

(1) Normal mode of operation

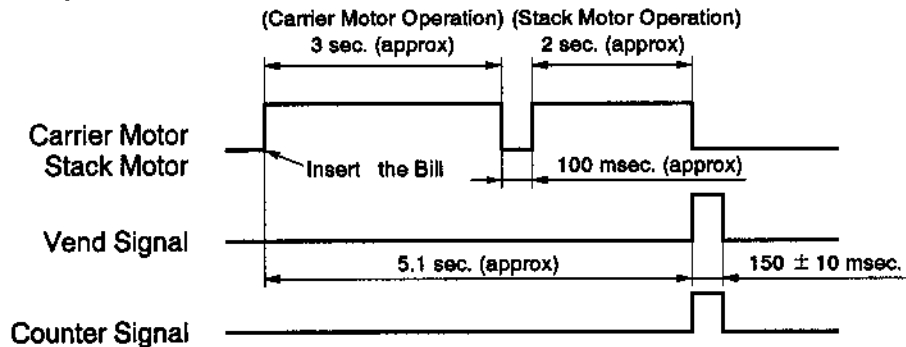

(2) Return mode of operation

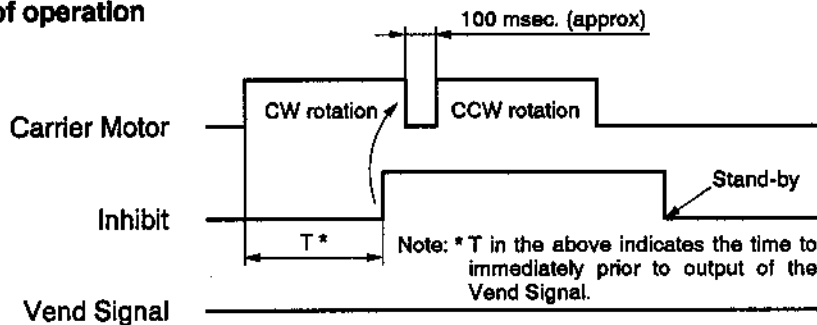

(3) When the stacker is full

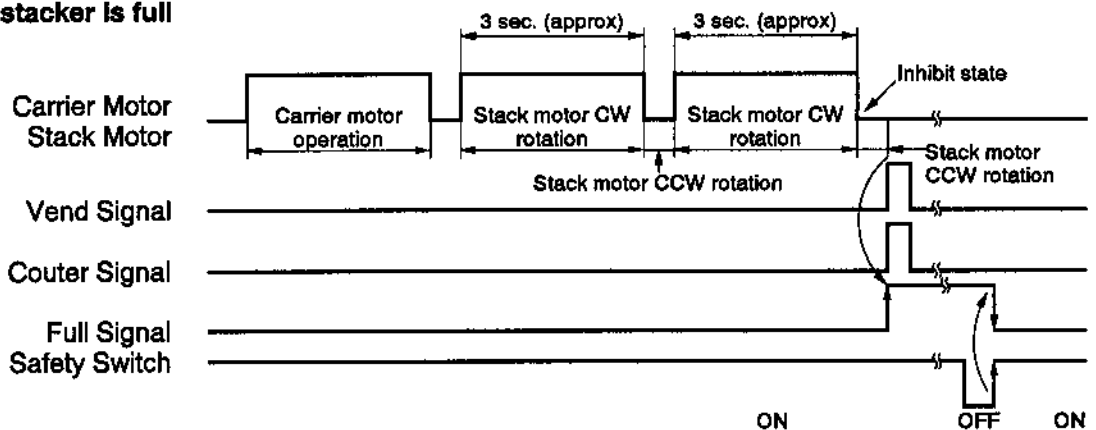

\* VOLTAGE MEASUREMENT

(1) AC voltage measurement

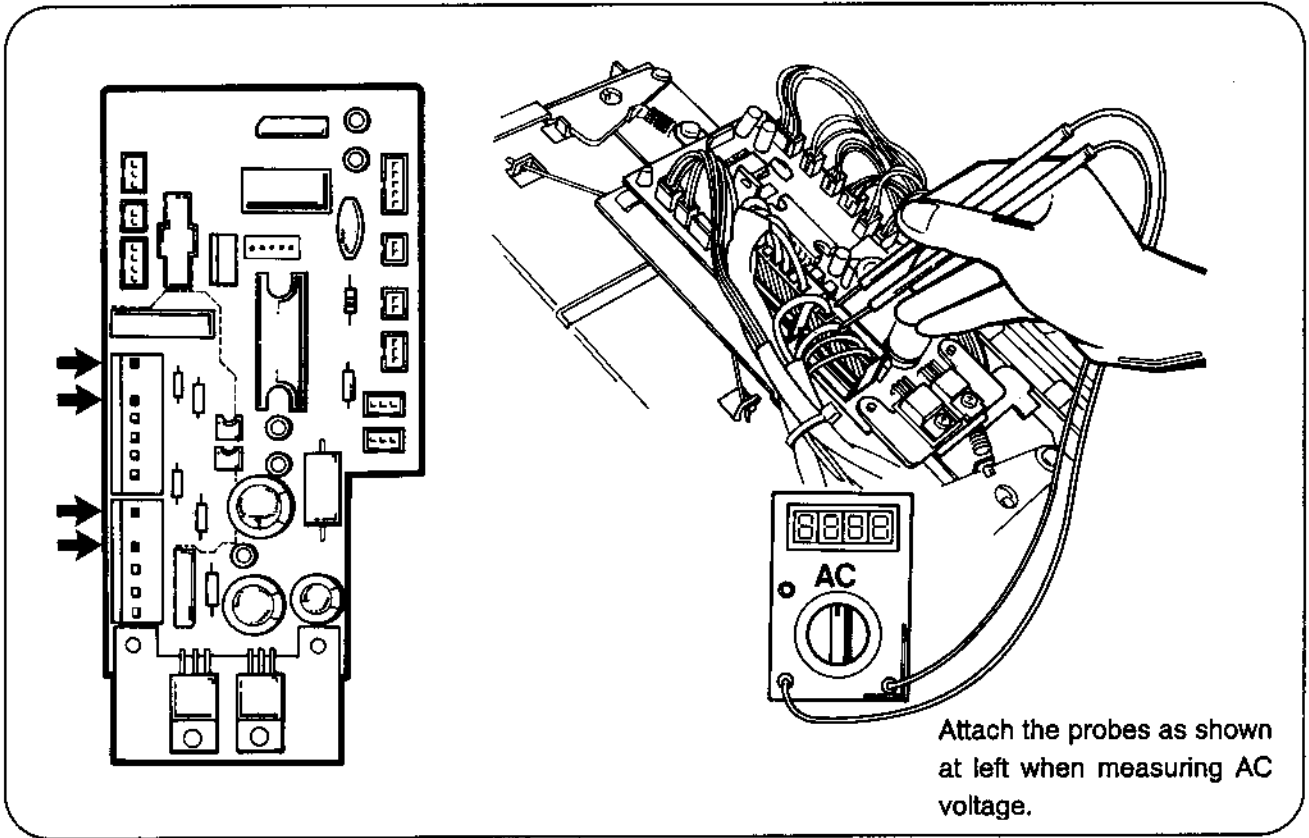

Attach the probes as shown at left when measuring AC voltage.

(2) DC voltage measurement

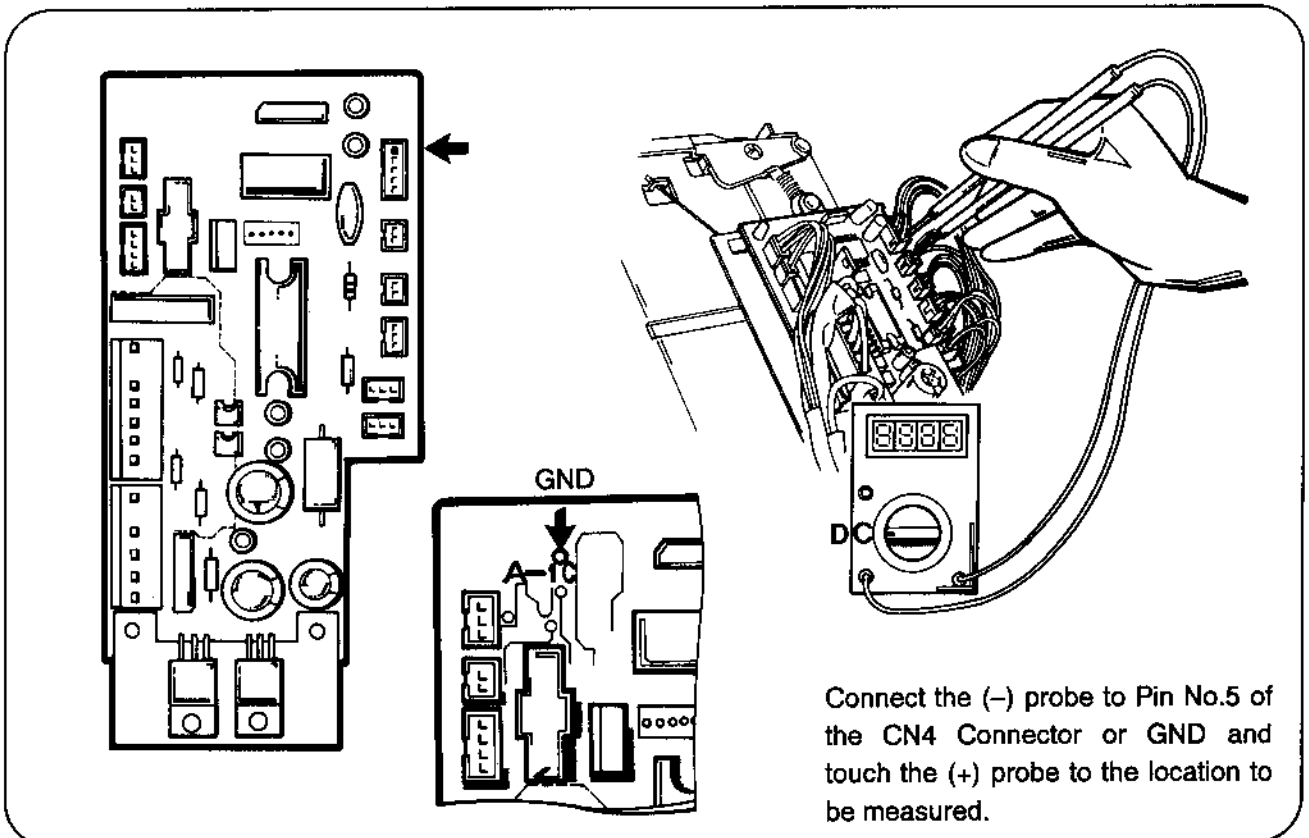



Connect the (-) probe to Pin No.5 of the CN4 Connector or GND and touch the (+) probe to the location to be measured.

## 7. SIGNALS OF CONNECTOR AND WIRING DIAGRAM

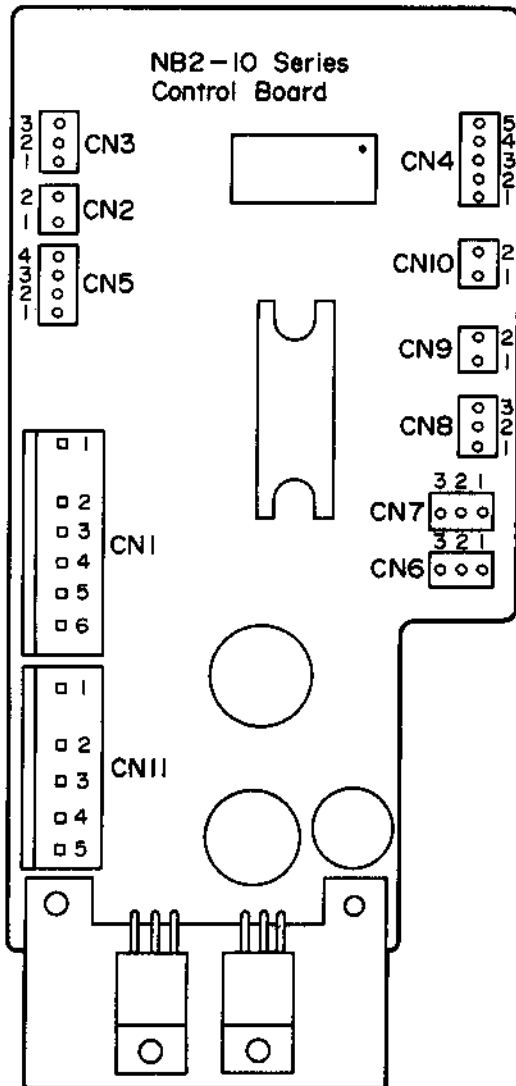
## 7-1 SIGNALS



Pin No.	Wire color	Input/Output	Signal	Voltage (V) during stand-by position	Voltage (V) during operation position	M. P.
<b>CN1 6P post</b>						
1	Blue	Input	Power supply	AC 117	AC 117	CN1-2
2	Red	Input	Power supply	AC 117	AC 117	CN1-1
3	Green	Input	"Inhibit" signal (1)	AC 117	0	CN1-2
4	—	—	—	—	—	—
5	Purple	Input	"Inhibit" signal (2)	0	AC 117	CN1-1
6	—	—	—	—	—	—
<b>CN2 2P post</b>						
1	Black	Output	"Vend" signal	Relay contacts closed for 150msec (approx.) at signal output		CN2-2
2	White			CN2-1		
<b>CN3 3P post</b>						
1	Brown	Output	+5V	DC 5	DC 5	0V DC (CN4-5)
2	Red	Input	Sensor (2) (shutter switch)	0	DC 5	0V DC (CN4-5)
3	Orange	Output	0V	0	0	0V DC (CN4-5)
<b>CN4 5P post</b>						
1	Brown	Input	Magnetic head (magnetic sensor)	0		0V DC (CN4-5)
2	Red	Output	0V DC GND	0	0	0V DC (CN4-5)
3	Green	Input	Magnetic head (magnetic sensor)	DC 4.2	DC 2.0	0V DC (CN4-5)
4	Orange	Input	Detector (Photo-interrupter)	DC 20	DC 20	0V DC (CN4-5)
5	Yellow	Output	0V DC GND	0	0	0V DC (CN4-5)
<b>CN5 4P post</b>						
1	Yellow	Output	"Full" signal	DC 24	0	0V DC (CN4-5)
2	Brown	Output	Power supply (+24V)	DC 24	DC 24	0V DC (CN4-5)
3	Red	Output	Power supply (+24V)	DC 24	DC 24	0V DC (CN4-5)
4	Blue	Output	"Counter" signal	DC 24	0	0V DC (CN4-5)
<b>CN6 3P post</b>						
1	Brown	Output	Carrier motor (CCW rotation)	0	DC 24	0V DC (CN4-5)
2	—	—	—	—	—	—
3	Orange	Output	Carrier motor (CW rotation)	0	DC 24	0V DC (CN4-5)
<b>CN7 3P post</b>						
1	Brown	Output	Stack motor (CCW rotation)	0	DC 24	0V DC (CN4-5)
2	—	—	—	—	—	—
3	Orange	Output	Stack motor (CW rotation)	0	DC 24	0V DC (CN4-5)
<b>CN8 3P post</b>						
1	Brown	Output	+5V	DC 5	DC 5	0V DC (CN4-5)
2	Red	Input	Sensor (1) (clock generator)	0		0V DC (CN4-5)
3	Orange	Output	0V	0	0	0V DC (CN4-5)
<b>CN9 2P post</b>						
1	Brown	Input	Safety switch	0	DC 5	0V DC (CN4-5)
2	Red	Output	0V DC power supply	0	0	0V DC (CN4-5)
<b>CN10 2P post</b>						
1	Brown	Input	Stack switch	DC 5	0	0V DC (CN4-5)
2	Red	Output	0V DC power supply	0	0	0V DC (CN4-5)
<b>CN11 5P post</b>						
1	Blue	Output	Power supply	AC 117	AC 117	CN11-2
2	Red	Output	Power supply	AC 117	AC 117	CN11-1
3	—	—	—	—	—	—
4	White	Input	Power supply secondary side	AC 24	AC 24	CN11-5
5	Black	Input	Power supply secondary side	AC 24	AC 24	CN11-4
<b>CN12 2P post</b>						
1	Red	Output	0V	0	0	0V DC (CN4-5)
2	Brown	Output	LED (photo-interrupter)	DC 1.2	DC 1.2	0V DC (CN4-5)

7-2 WIRING DIAGRAM

7-2 WIRING DIAGRAM

Option

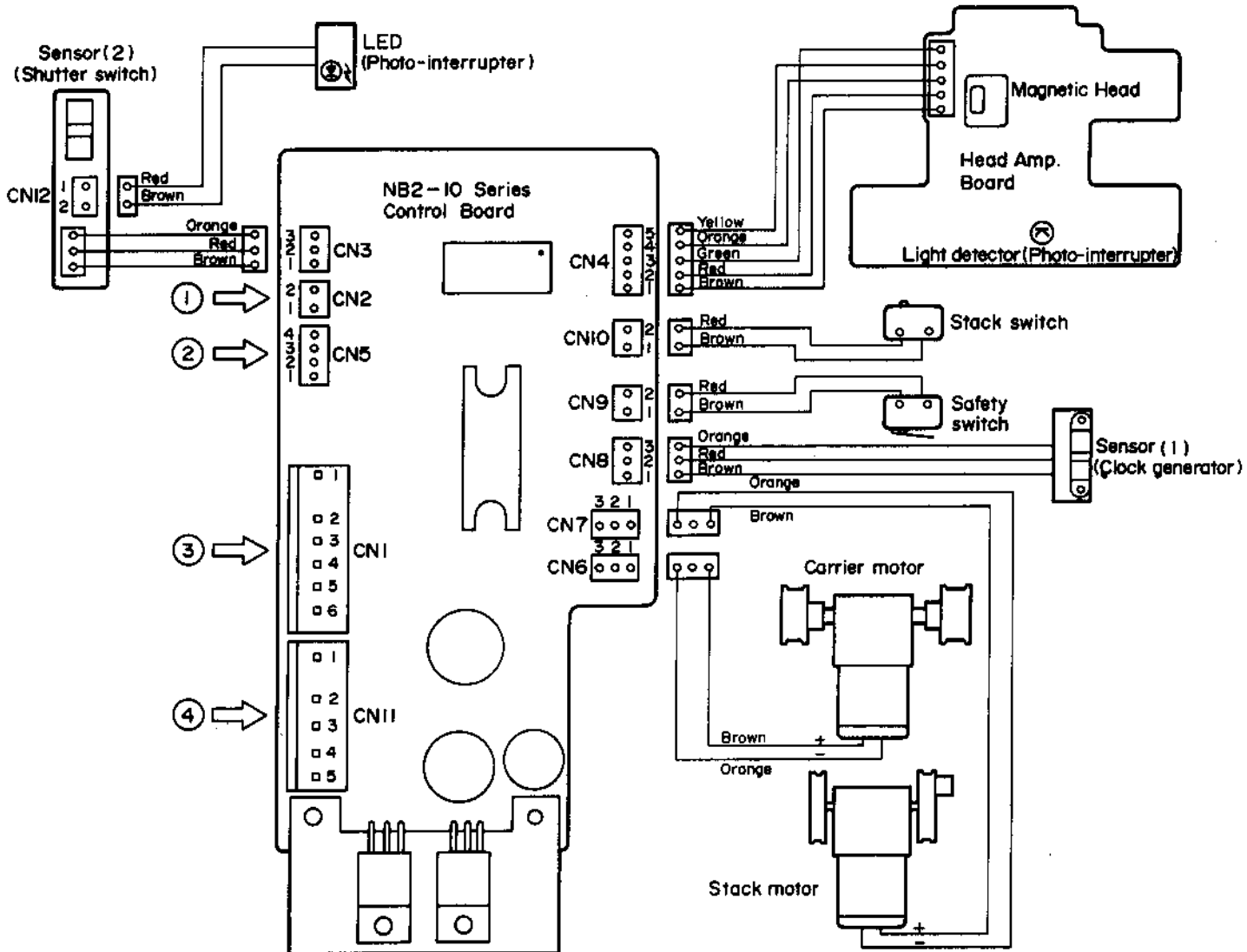
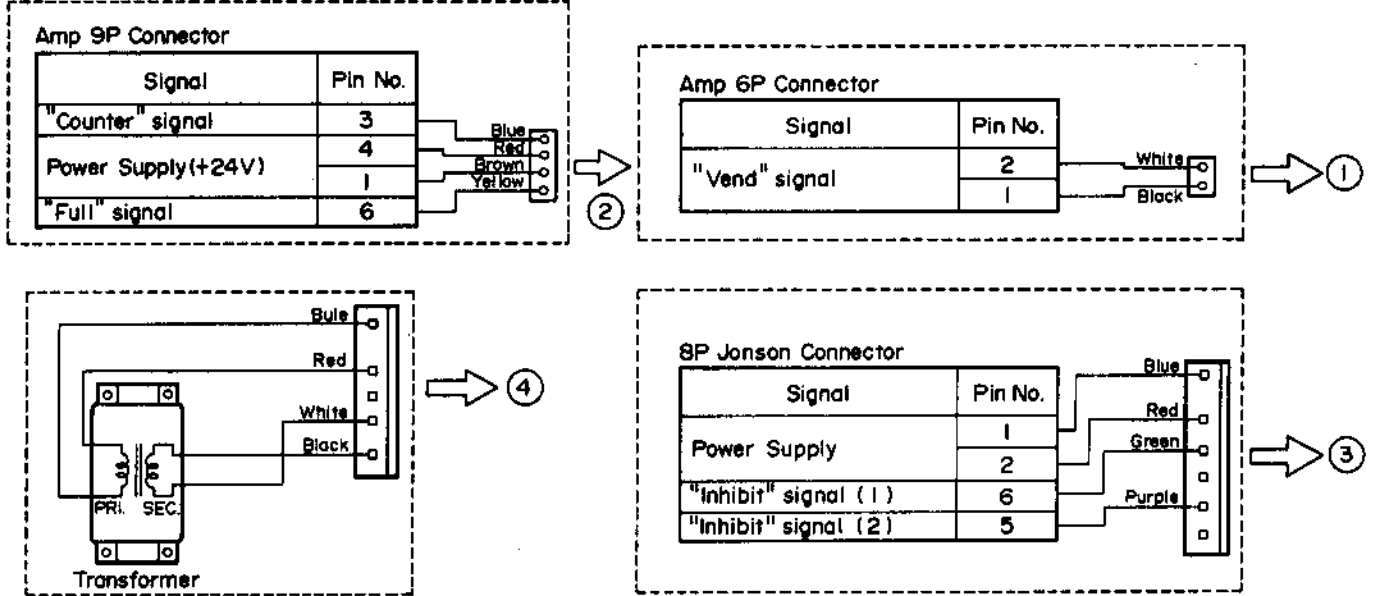

### 8. DISASSEMBLY AND ASSEMBLY POINT

#### 8-1 ASSEMBLY COMPOSITION

Chute (A) assembly

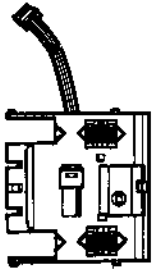

Chute (B) assembly

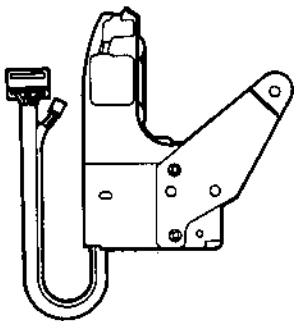

Front mask (H)

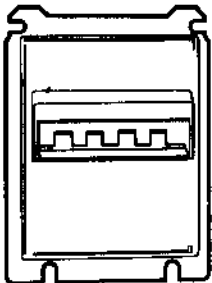

Mask base

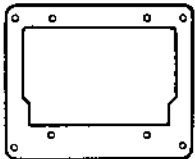

Housing assembly

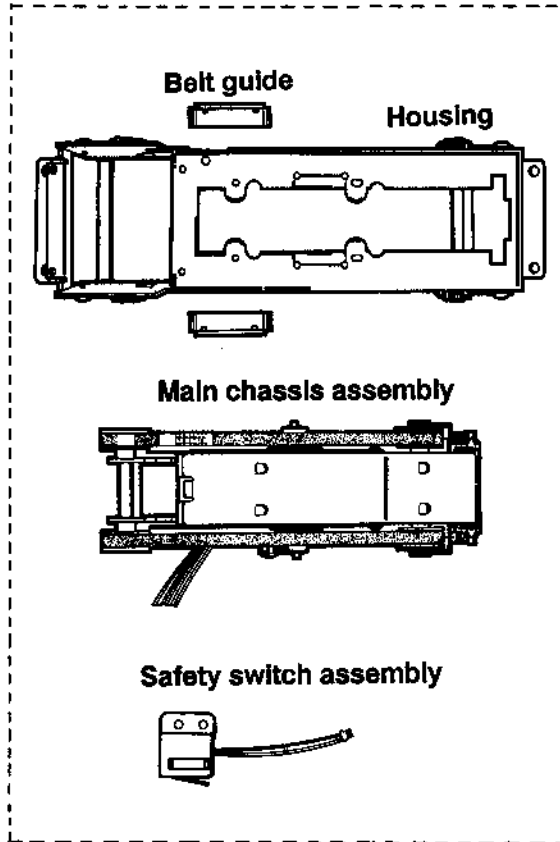

Control assembly

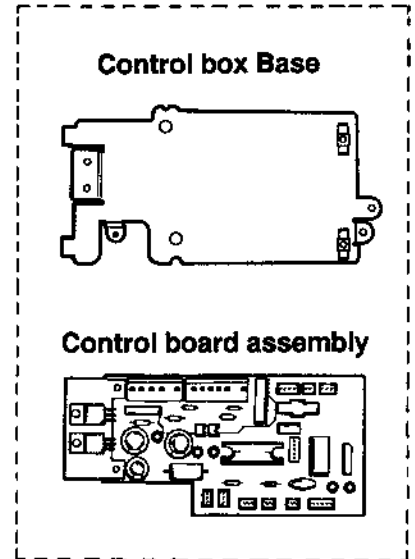

Control box Base

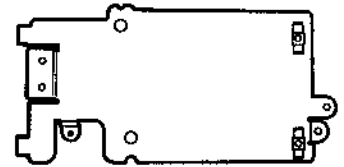

Control board assembly

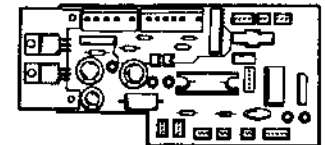

Control box cover

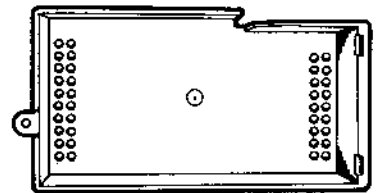

Stacker (G) assembly

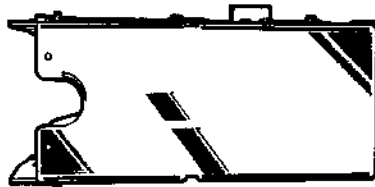

Harness 1 assembly

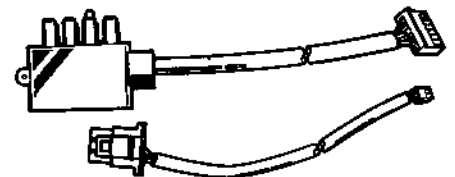

Harness 2 assembly





**8-2 DISASSEMBLY AND ASSEMBLY PROCEDURE**

(assembly in reverse order to disassembly)

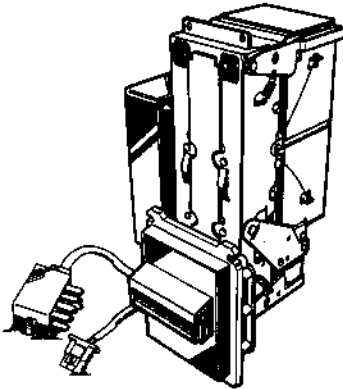
**(1) Overall view of NB2-10 Series****(2) Removing the control box cover**

Remove the one screw holding the control box.

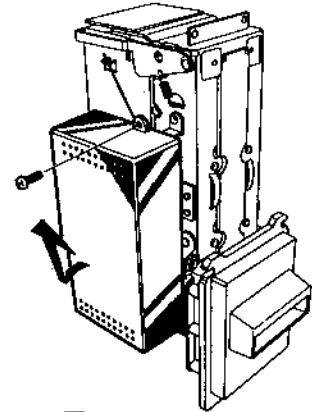
**(3) Removing the control board assembly**

- 1) Gently remove the connectors plugged into the control board assembly.
- 2) Cut the tie wrap and remove the harnesses from the control base.
- 3) Remove the control board assembly from the the control base.
- 4) Remove the two screws holding the control base.

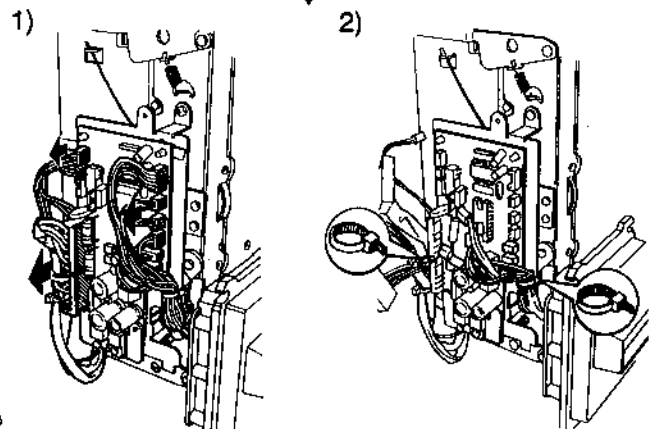
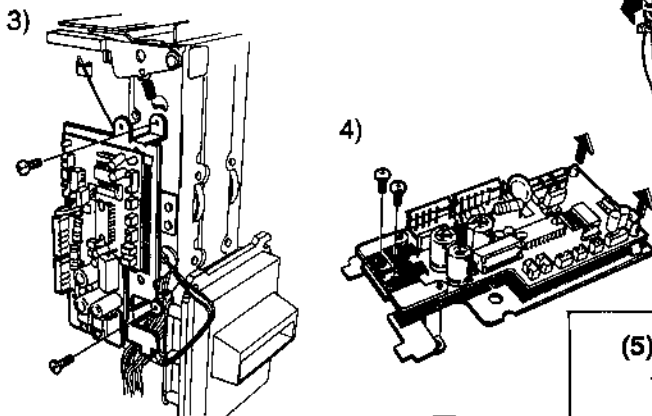
**(4) Removing the stacker assembly**

Lift the stacker, and remove the two arm shafts (B).

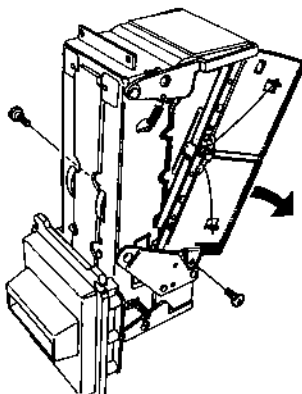
**(5) Removing the front mask (H) and the mask base**

- 1) Remove the 4 screws holding the front mask (H).  
※ 3 × 1.06 × 12 Tapping screws
- 2) Remove the 4 screws fixing the mask base and remove the mask base.

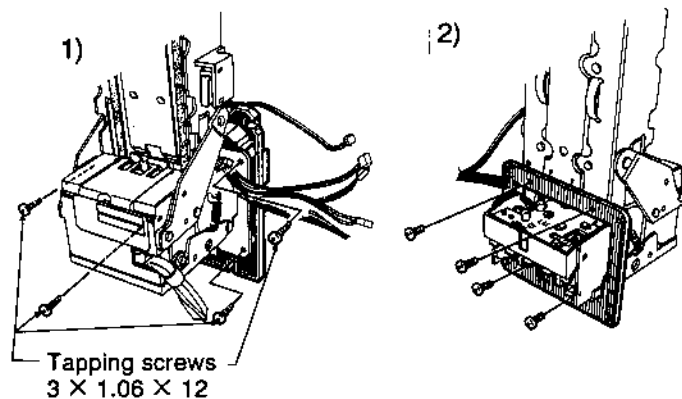
Tapping screws  
3 × 1.06 × 12

- (6) Removing the chute (B) assembly**  
Remove the two arm shafts (A).

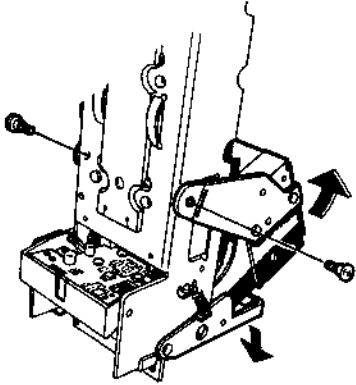

- (7) Removing the chute (A) assembly**  
Disengage the latch at the front with a flat screwdriver, and then hold at the top and disengage the latch at the rear.

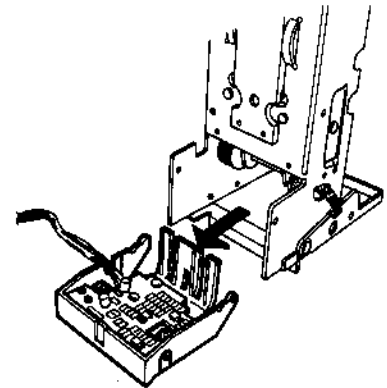
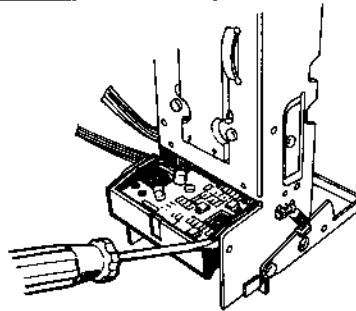
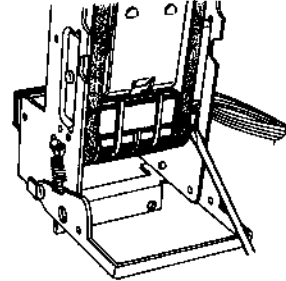

- (8) Removing the main chassis assembly**  
1) Cut the tie wrap and remove the two belt guides.  
2) Remove the 4 screws holding the main chassis assembly.

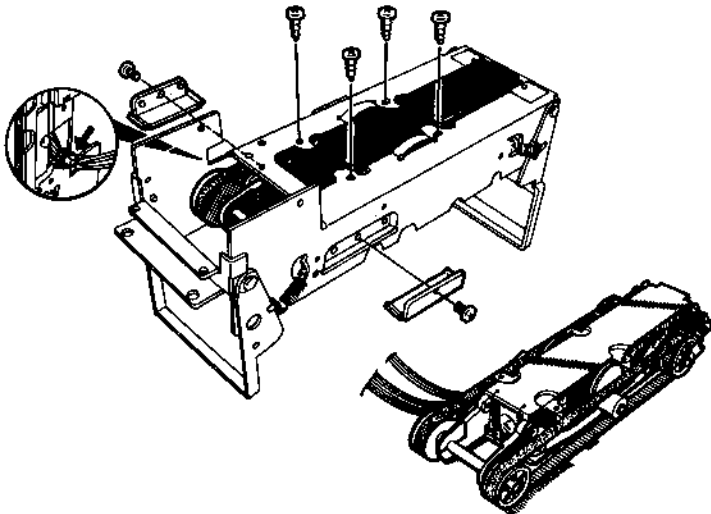

- (9) Removing the safety switch assembly**  
Removing the two screws holding the safety switch assembly.

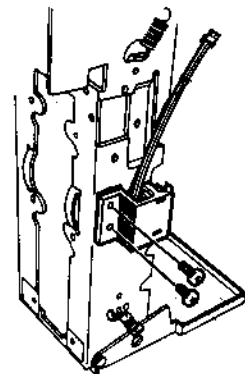

## 9. CLEANING

If the moving parts become dirty, get wet, or are stuck with foreign particles, proper operation cannot be maintained. Clean according to the requirements of the situation.

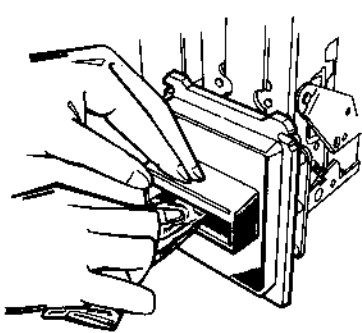

Wipe Bill Insertion Opening with a soft cloth.

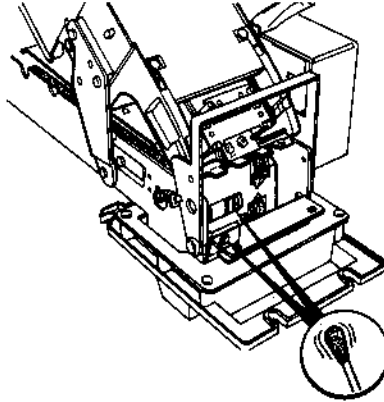

Clean the photo-sensor and magnetic head with an applicator.

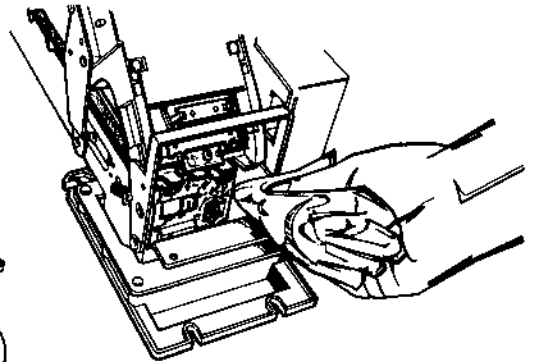

Wipe clean the chute roller, and belt with a soft cloth.

### Back Side View

Clean the belt and the rubber roller with a cotton swab moistened with alcohol.

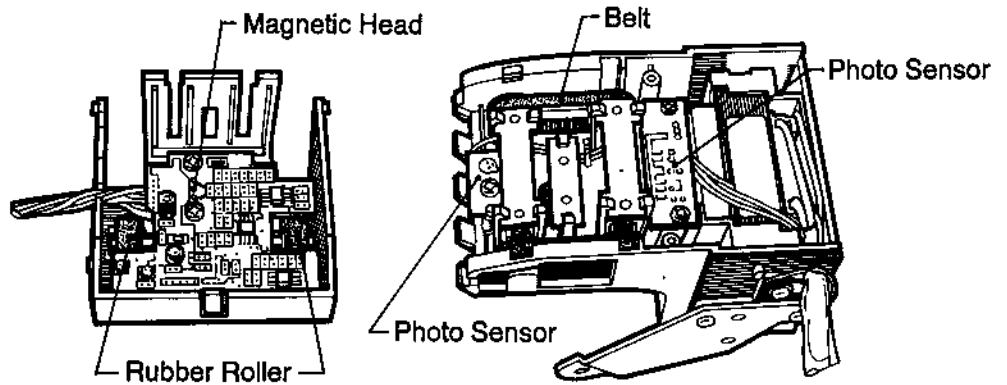

## 10. INSPECTION

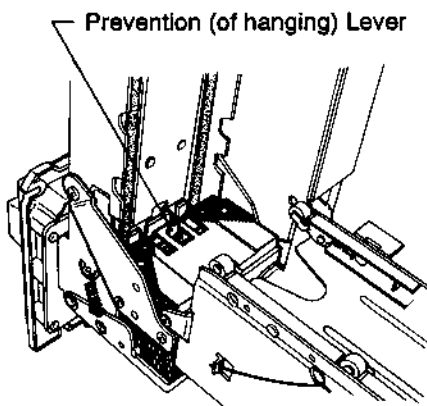

- Prevention (of hanging) Lever  
It should pull out easily and when released, return smoothly without sticking.

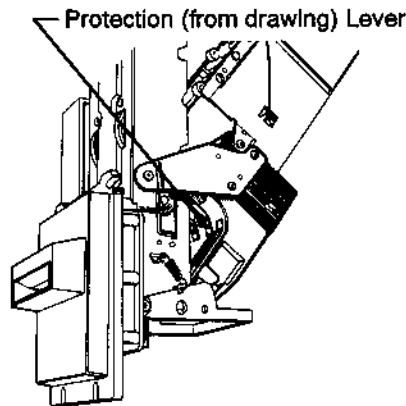

- Protection (from drawing) Lever  
It should push easily, and when released, return smoothly without sticking.

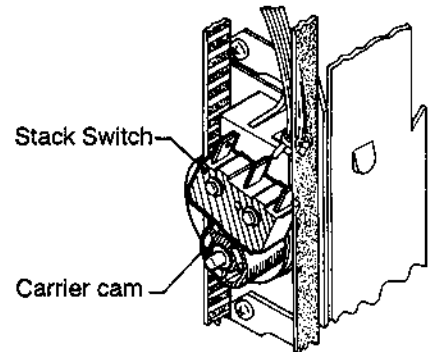

- Carrier cam and switch  
Confirm the operation condition of carrier cam and switch.

## 11. TROUBLE-SHOOTING

### A Guide to the Diagnosis of Faults

Broken parts and faulty wiring are not included.

- (1) No Movement When the Power is Turned On
- (2) When the Power is Turned On, the Motor Continues to Run in Reverse
- (3) No Stacking Operation or Stacking Operation is Slow.
- (4) Stacking Operation Continues When Power is Turned On
- (5) The Motor Continues to Run After the Stacking Operation
- (6) The Bills are Returned Part Way Through the Operation
- (7) The Bills are Not Received When they are Inserted
- (8) The "Authentic Bill" Signal is not sent out

#### (1) No Movement When the Power is Turned On

Main Causes 1. Stacker installation 2. Safety switch 3. Power supply  
4. Control board 5. Transformer 6. Carrier motor

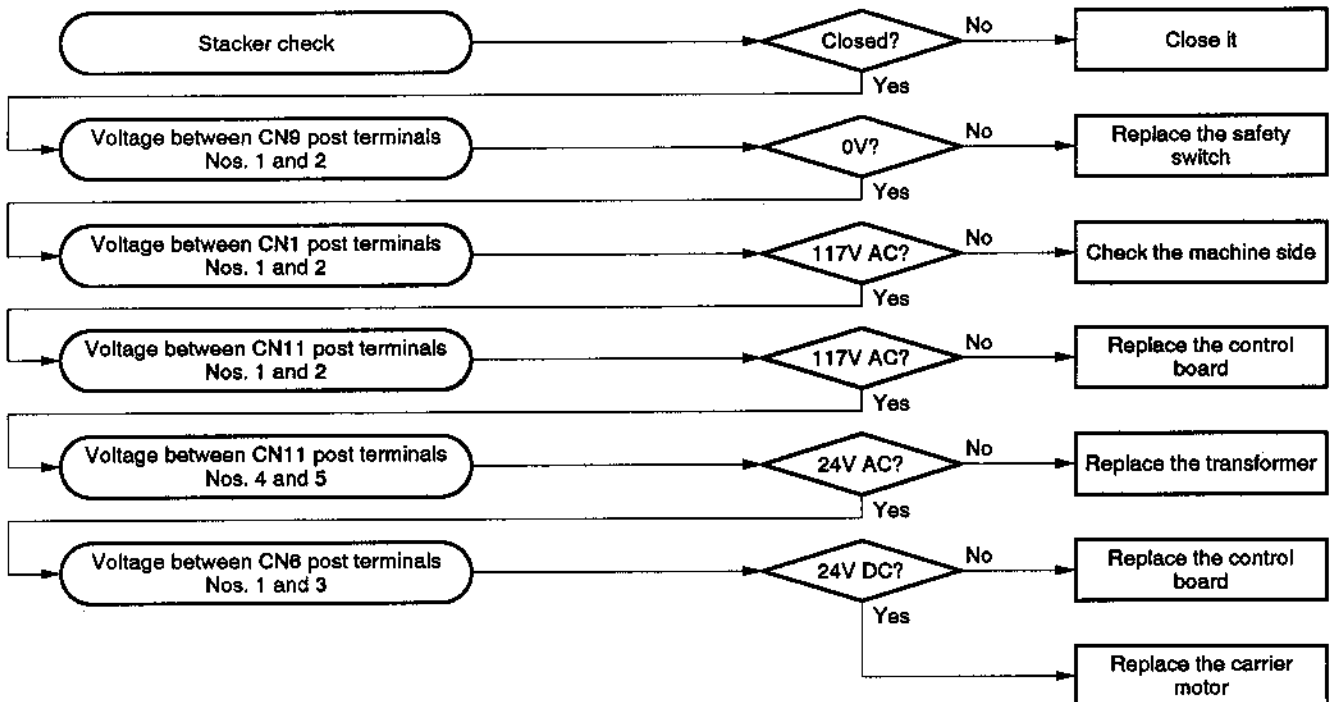

#### (2) When the power is Turned On, the Motor Continues to Run in Reverse

Main Causes 1. Control board 2. Pull out protection lever 3. Sensor (2) (Shutter switch)

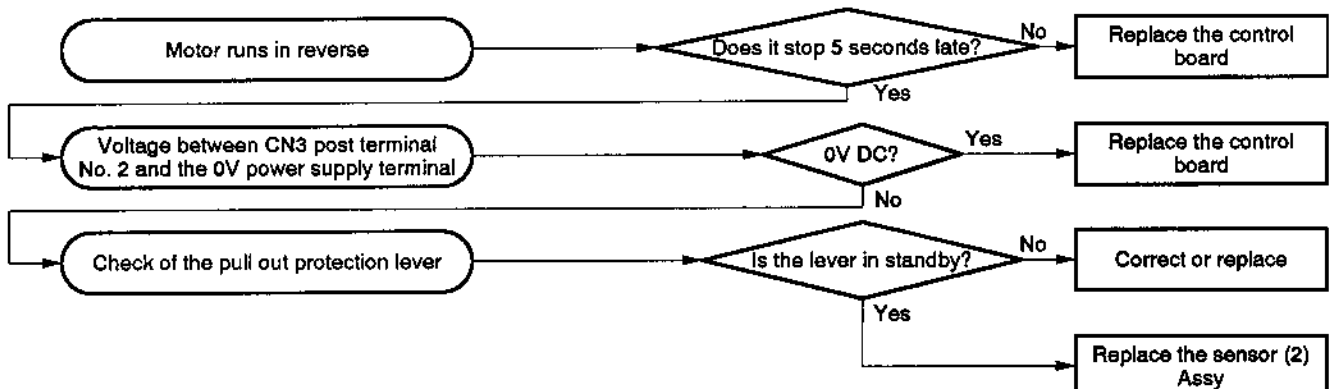

# 11. TROUBLE-SHOOTING

### (3) No Stacking Operation or Stacking Operation is Slow.

Main Causes 1. Stack motor 2. Control board 3. Sensor (1) (Clock generator)  
4. Sensor (2) (Shutter switch) 5. Stack switch

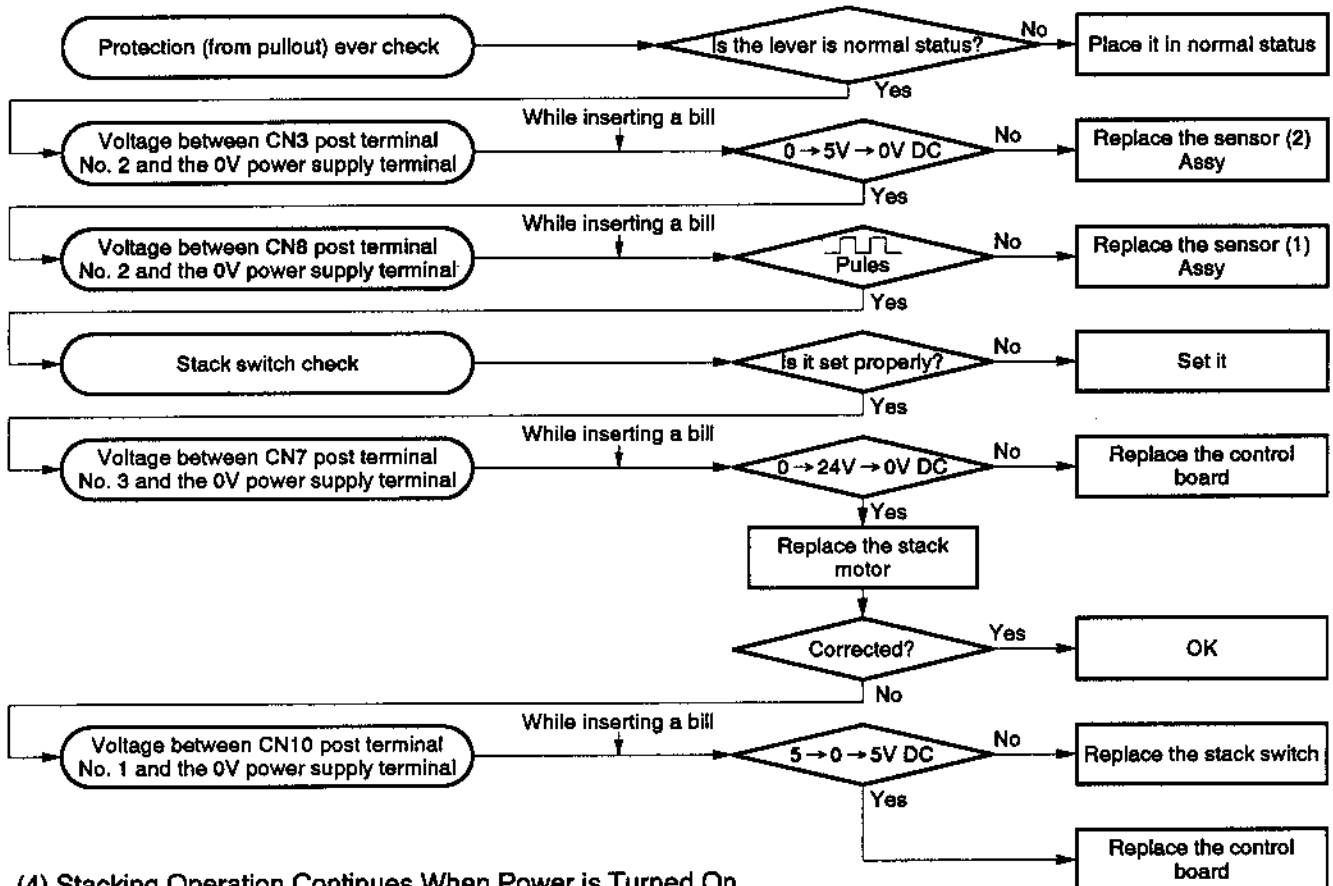

### (4) Stacking Operation Continues When Power is Turned On

Main Causes 1. Control board 2. Stack switch

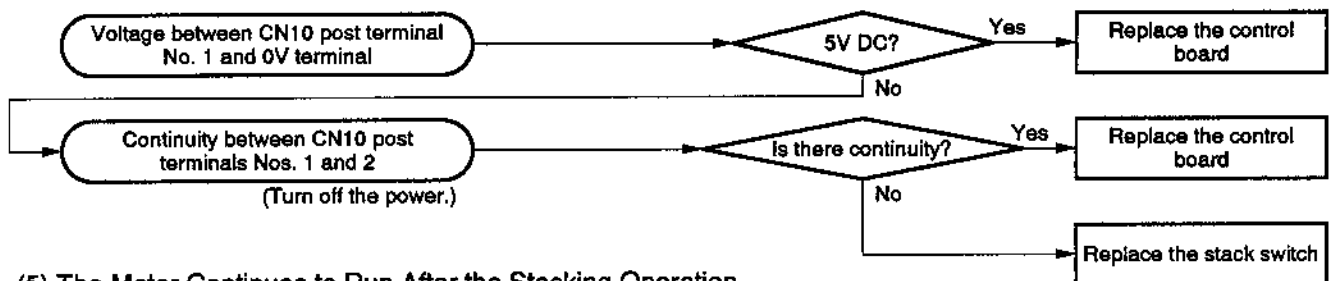

### (5) The Motor Continues to Run After the Stacking Operation.

Main Causes 1. Control board 2. LED Assy (Photo-interrupter) 3. Head Amp. board Assy (Photo-interrupter)

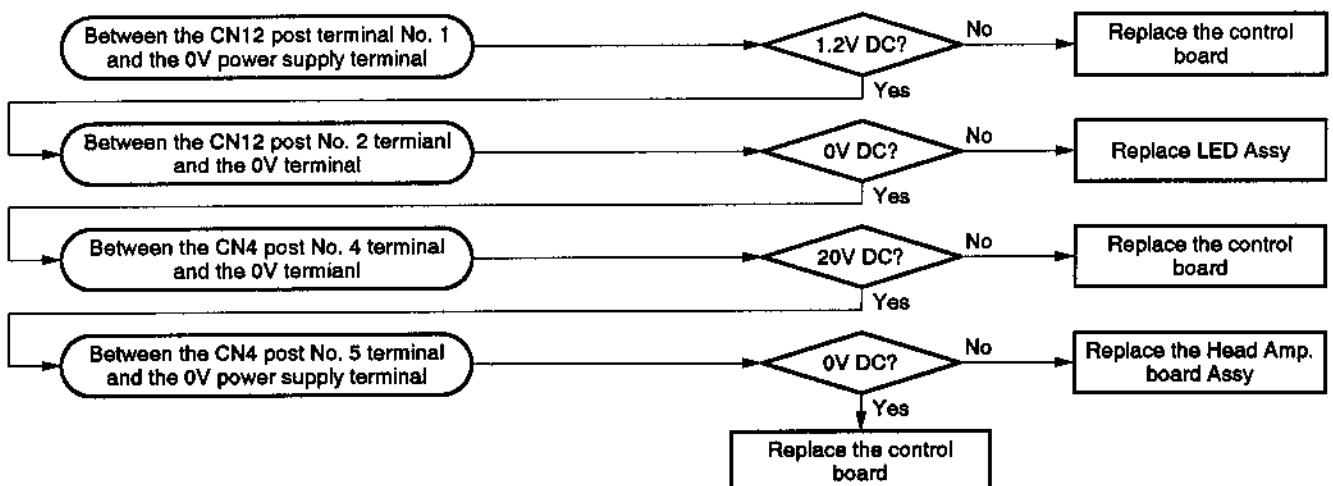

(6) The Bills are Returned Part Way Through the Operation

Main Causes 1. Pull out protection lever 2. Sensor (2) Assy (Shutter switch) 3. Control board  
4. Head Amp. board Assy (Magnetic head)

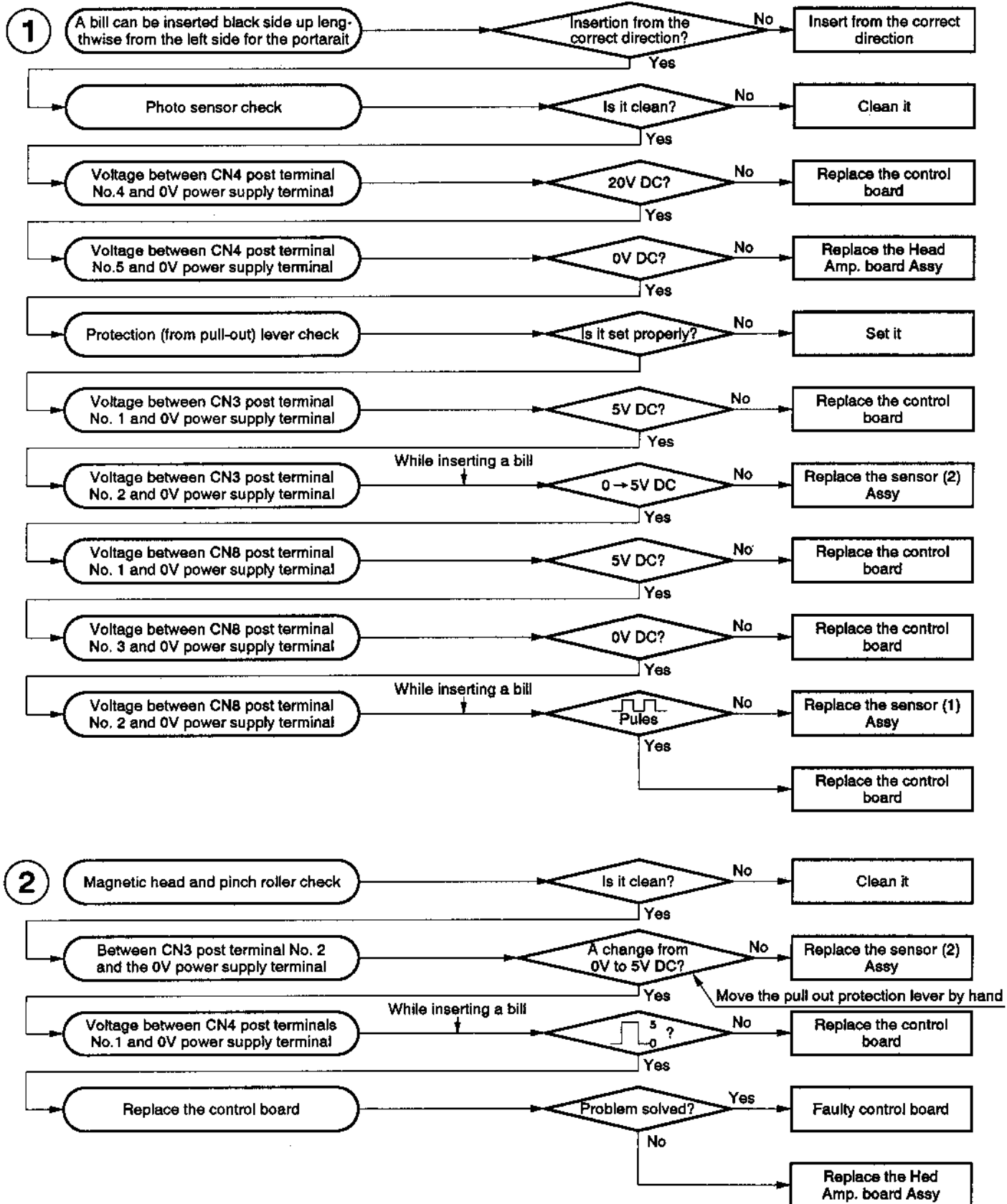

# 11. TROUBLE-SHOOTING

## (7) The Bills are Not Received When they are Inserted

Main Causes 1. Reception inhibition signal 2. Control board 3. Head Amp. board Assy (Magnetic head)

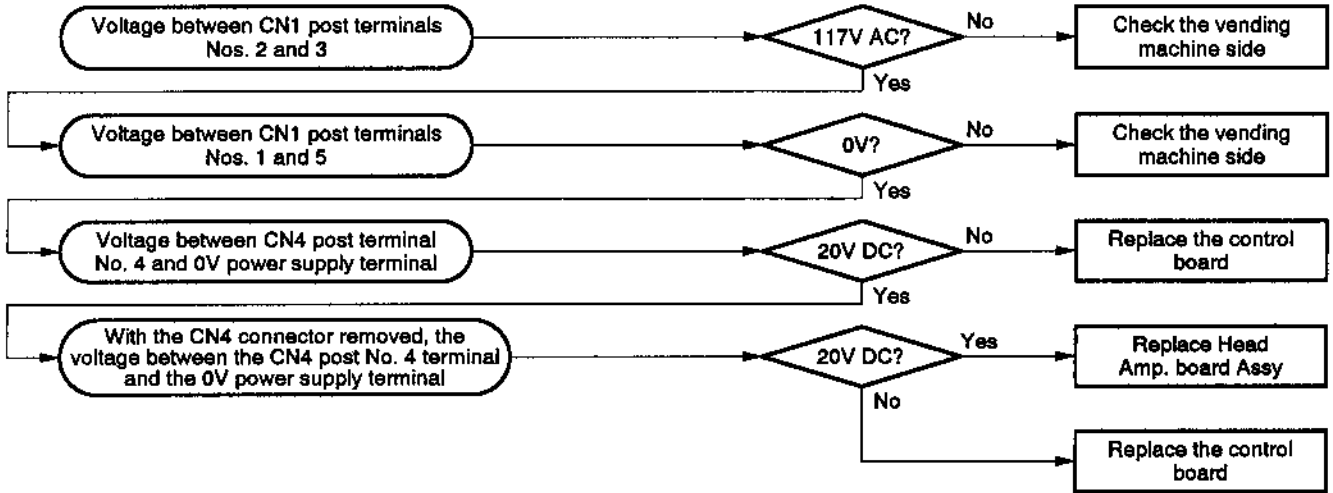

## (8) The "Authentic Bill" signal is not sent out.

- When the "Authentic Bill" signal is not sent out.  
Pull the AMP 6P plug.

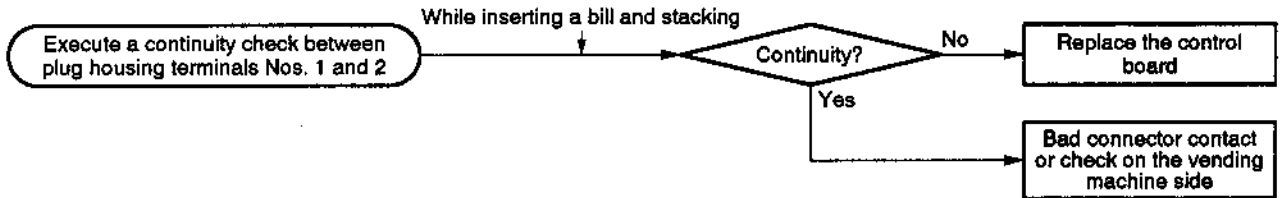

- No output the counter signal.

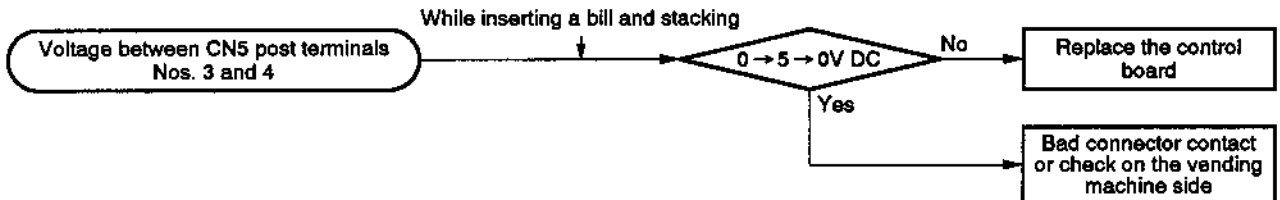

- The "Full" signal is not sent out.

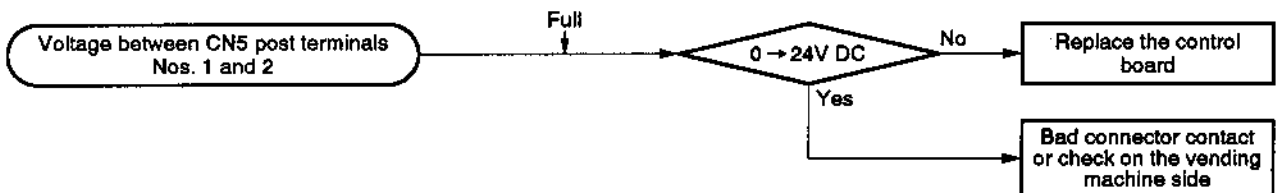

12. EXPLODED VIEW AND PARTS LIST

12-1 NB2-10 SERIES COMPOSITION

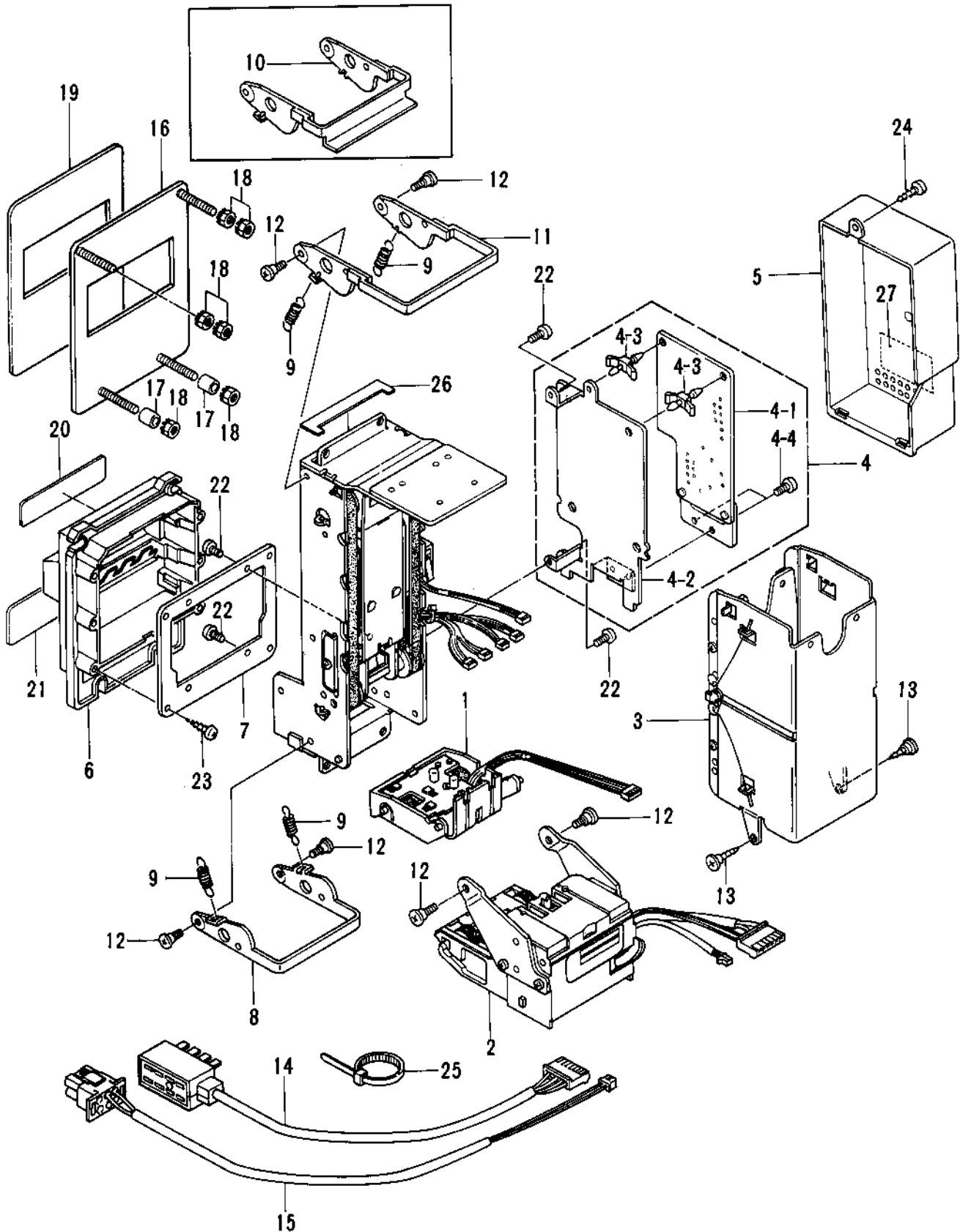



## 12-1 NB2-10 SERIES COMPOSITION

INDEX NO.	PARTS NO.	DESCRIPTION	Q'TY	REMARKS	A	B	C	D
1	457105	Chute (A) ASSY	1		○	○	○	○
2	457106	Chute (B) ASSY	1		○	○	○	○
3	440704	Stacker ASSY 200	1		○		○	
	440128	Stacker ASSY 400	1			○		○
4	457108	Control ASSY	1		○	○	○	○
4-1	457203	Control Board ASSY	1		○	○	○	○
4-2	457504	Control Box Base	1		○	○	○	○
4-3	994128	Board Supporter	2		○	○	○	○
4-4	905103	Self Tapping Screw (+) Pan-head 3 × 8	2		○	○	○	○
5	457403	Control Box Cover	1		○	○	○	○
6	457404	Front Mask (H)	1		○	○	○	○
7	440820	Mask Base	1		○	○	○	○
8	440506	Latch	1		○	○	○	○
9	440576	Latch Spring	4		○	○	○	○
10	440902	Latch 200	1		○	○	○	
11	440584	Latch (G)	1			○		○
12	447514	Arm Shaft (A)	6		○	○	○	○
13	447515	Arm Shaft (B)	2		○	○	○	○
14	457301	Harness 1	1		○	○	○	○
15	457302	Harness 2	1		○	○	○	○
16	100053	Mounting Bracket	1		○	○		
17	100023	Bracket Spacer	2		○	○		
18	100005	Nut with Toothed Washer	6		○	○		
19	100074	Decal (Yellow-background)	1		○	○		
20	440818	Decal (1)	1				○	○
21	457801	Decal (2B)	1				○	○
22	900018	Screw (+/-) Pan-head M3 × 5	6		○	○	○	○
23	904317	Self Tapping Screw (+) Pan-head 3 × 12	4	The same screw as No. 905004	○	○	○	○
24	905103	Self Tapping Screw (+) Pan-head 3 × 8	1		○	○	○	○
25	994047	Tie Wrap	2		○	○	○	○
26	440951	Seal (A)	1		○	○	○	○
27	440931	U. S. PATENT Seal (1)	1		○	○	○	○

12-2 CHUTE (A) ASSY

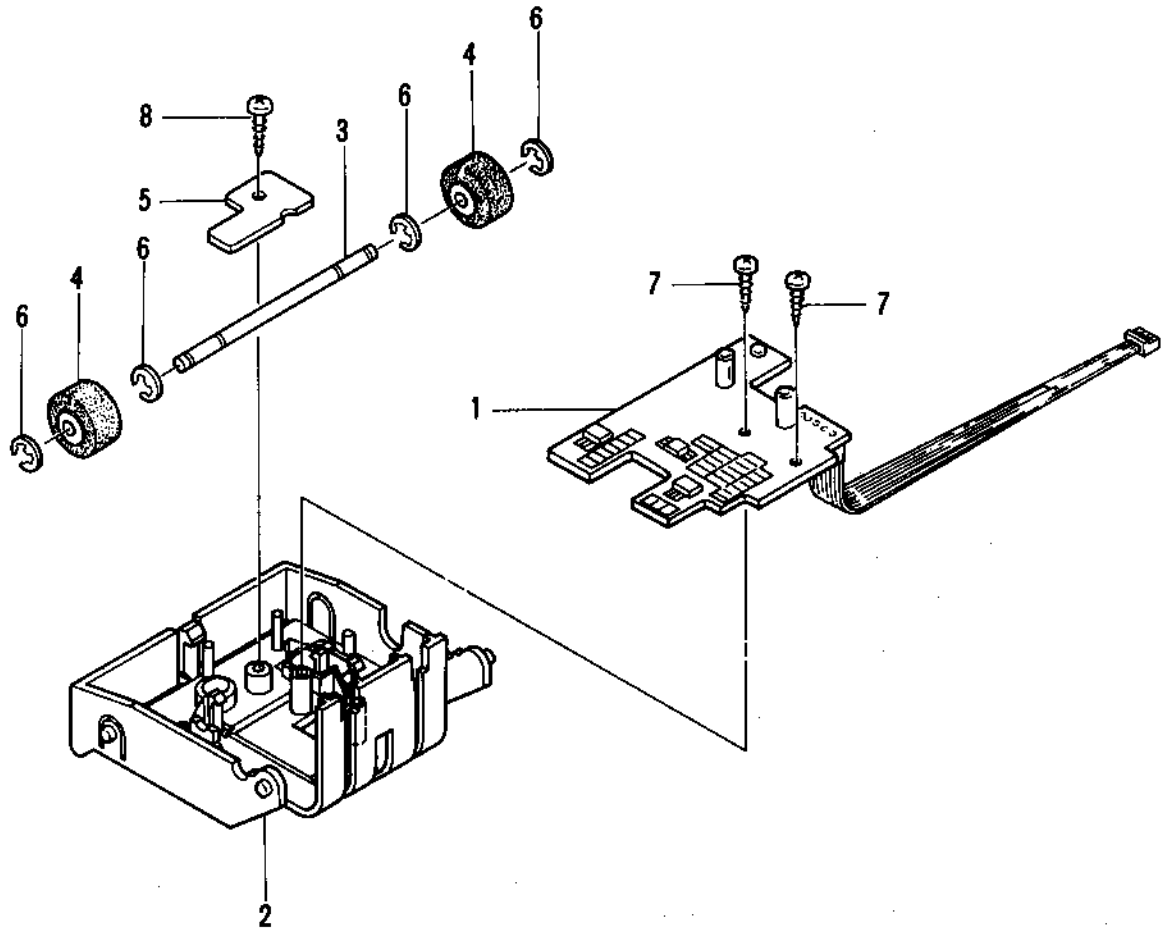

INDEX NO.	PARTS NO.	DESCRIPTION	Q'TY	REMARKS	A	B	C	D
	457105	Chute (A) ASSY	1		○	○	○	○
1	457207	Head Amp. Board ASSY	1		○	○	○	○
2	457401	Chute (A)	1		○	○	○	○
3	440894	Carrier Roller Pin	1		○	○	○	○
4	412418	Pinch Roller	2		○	○	○	○
5	457516	Plate	1		○	○	○	○
6	907403	E-ring φ 2	4		○	○	○	○
7	904209	Self Tapping Screw (+) Pan-head 3 × 8	2	The same screw as No. 905011	○	○	○	○
8	904806	Self Tapping Screw (+) Bind 3 × 6	1		○	○	○	○

12-3 HOUSING ASSY

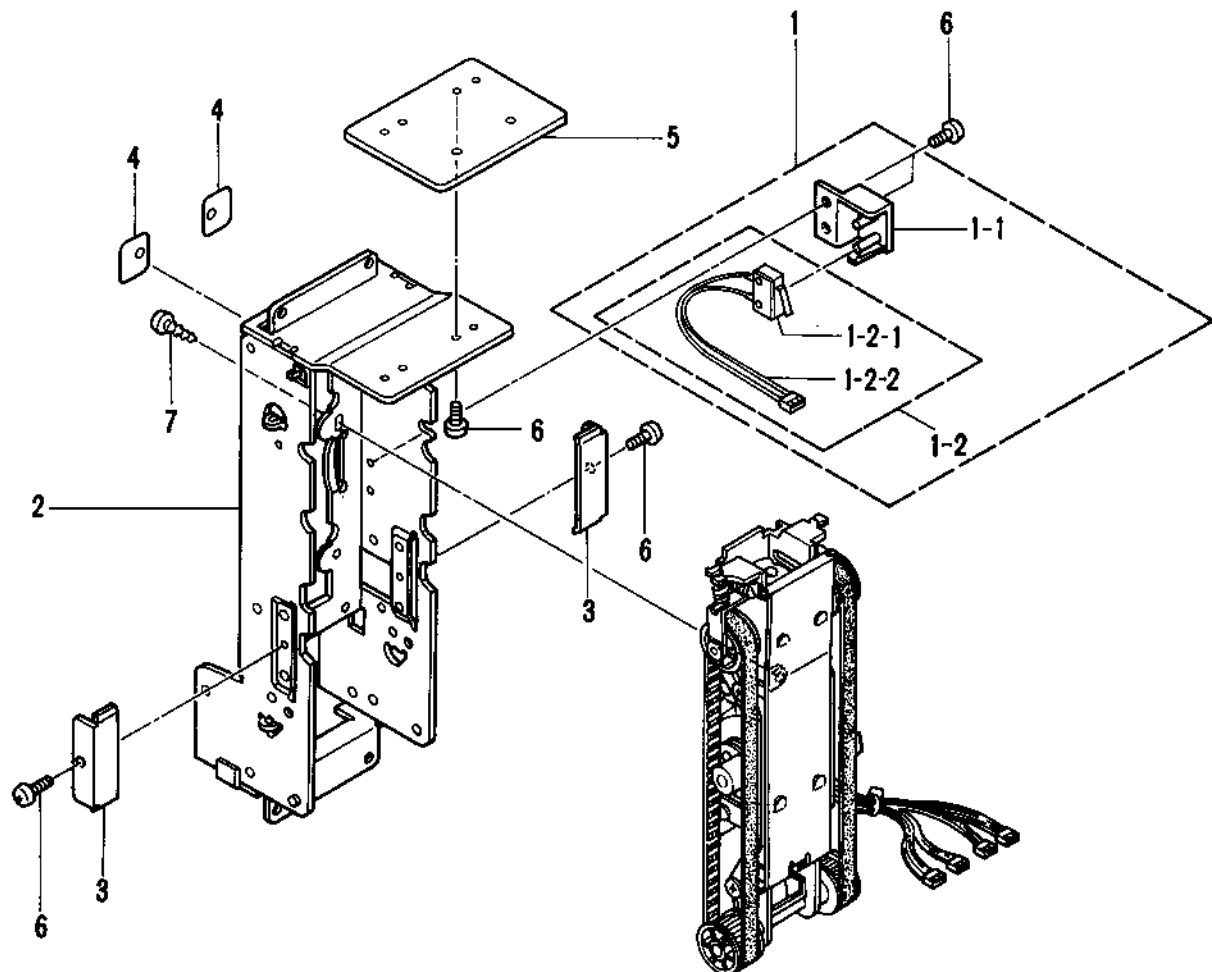

INDEX NO.	PARTS NO.	DESCRIPTION	Q'TY	REMARKS	A	B	C	D
1	457103	Safety Switch ASSY	1		○	○	○	○
1-1	457409	Safety Switch Mounting Plate	1		○	○	○	○
1-2	457217	Safety Switch Harness ASSY	1		○	○	○	○
1-2-1	993026	Safety Switch	1		○	○	○	○
1-2-2	457309	Harness 9	1		○	○	○	○
2	440868	Housing	1		○	○	○	○
3	457411	Belt Guide	2		○	○	○	○
4	440590	Lift Spring Seal	2		○	○	○	○
5	440585	Stacker Roof (G)(for 400 bills)	1			○		○
6	900018	Screw (+/-) Pan-head M3 × 5	4		○	6	○	6
7	904208	Self Tapping Screw (+) Pan-head 3 × 6	4		○	○	○	○

A: NB2-10L-200, B: NB2-10L-400, C: NB2-15A-200, D: NB2-15A-400

12-4 MAIN CHASSIS ASSY

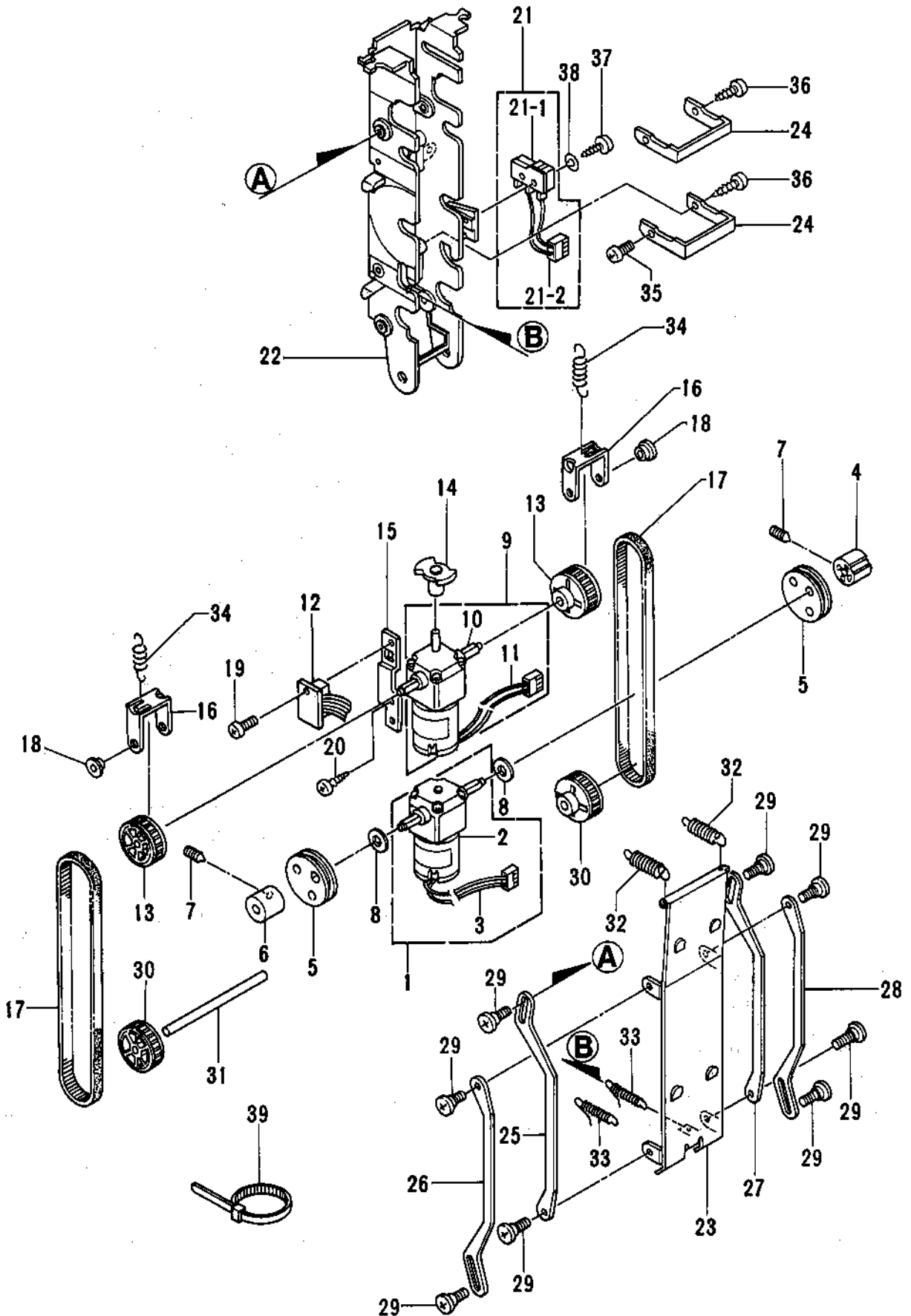

## 12-4 MAIN CHASSIS ASSY

① 91-3

INDEX NO.	PARTS NO.	DESCRIPTION	Q'TY	REMARKS	A	B	C	D
1	457218	Stack Motor Harness ASSY	1		○	○	○	○
2	440130	Stack Motor ASSY	1		○	○	○	○
3	457307	Harness 7	1		○	○	○	○
4	440406	Carrier Cam	1		○	○	○	○
5	440535	Lift Cam	2		○	○	○	○
6	443598	Cam Stopper	1		○	○	○	○
7	906007	Set Screw Flat tip M3 × 4	2		○	○	○	○
8	907908	Plastic Washer φ 5	2		○	○	○	○
9	457219	Carrier Motor Harness ASSY	1		○	○	○	○
10	440131	Carrier Motor ASSY	1		○	○	○	○
11	457306	Harness 6	1		○	○	○	○
12	457211	Sensor (1) ASSY	1		○	○	○	○
13	440459	Large Pulley (1)	2		○	○	○	○
14	440463	Tachmeter	1		○	○	○	○
15	440516	Tachmeter Bracket	1		○	○	○	○
16	440529	Spring Bracket	2		○	○	○	○
17	440533	Belt (2)	2		○	○	○	○
18	440570	Guide Spacer	2		○	○	○	○
19	900008	Screw (+/-) Pan-head M3 × 6	1		○	○	○	○
20	904209	Self Tapping Screw (+) Pan-head 3 × 8	1	The same screw as No. 905011	○	○	○	○
21	457102	Carrier Switch ASSY	1		○	○	○	○
21-1	993020	Carrier Switch	1		○	○	○	○
21-2	457310	Harness 10	1		○	○	○	○
22	440456	Main Chassis	1		○	○	○	○
23	440504	Lift Base	1		○	○	○	○
24	440514	Motor Bracket	2		○	○	○	○
25	440824	Lift Lever (1) L	1		○	○	○	○
26	440825	Lift Lever (2) L	1		○	○	○	○
27	440530	Lift Lever (1) R	1		○	○	○	○
28	440568	Lift Lever (2) R	1		○	○	○	○
29	440539	Lift Lever Shaft	8		○	○	○	○
30	440460	Large Pulley (2)	2		○	○	○	○
31	440536	Large Pulley Shaft	1		○	○	○	○
32	440542	Lift Spring (1)	2		○	○	○	○
33	440564	Lift Spring (2)	2		○	○	○	○
34	440543	Belt Spring	2		○	○	○	○
35	900018	Screw (+/-) Pan-head M3 × 5	1		○	○	○	○
36	904208	Self Tapping Screw (+) Pan-head 3 × 6	3		○	○	○	○
37	904312	Self Tapping Screw (+) Pan-head 2 × 10	2	The same screw as No. 905002	○	○	○	○
38	907209	Spring Washer φ 2	2		○	○	○	○
39	994047	Tie Wrap	1		○	○	○	○

12-5 CHUTE (B) ASSY

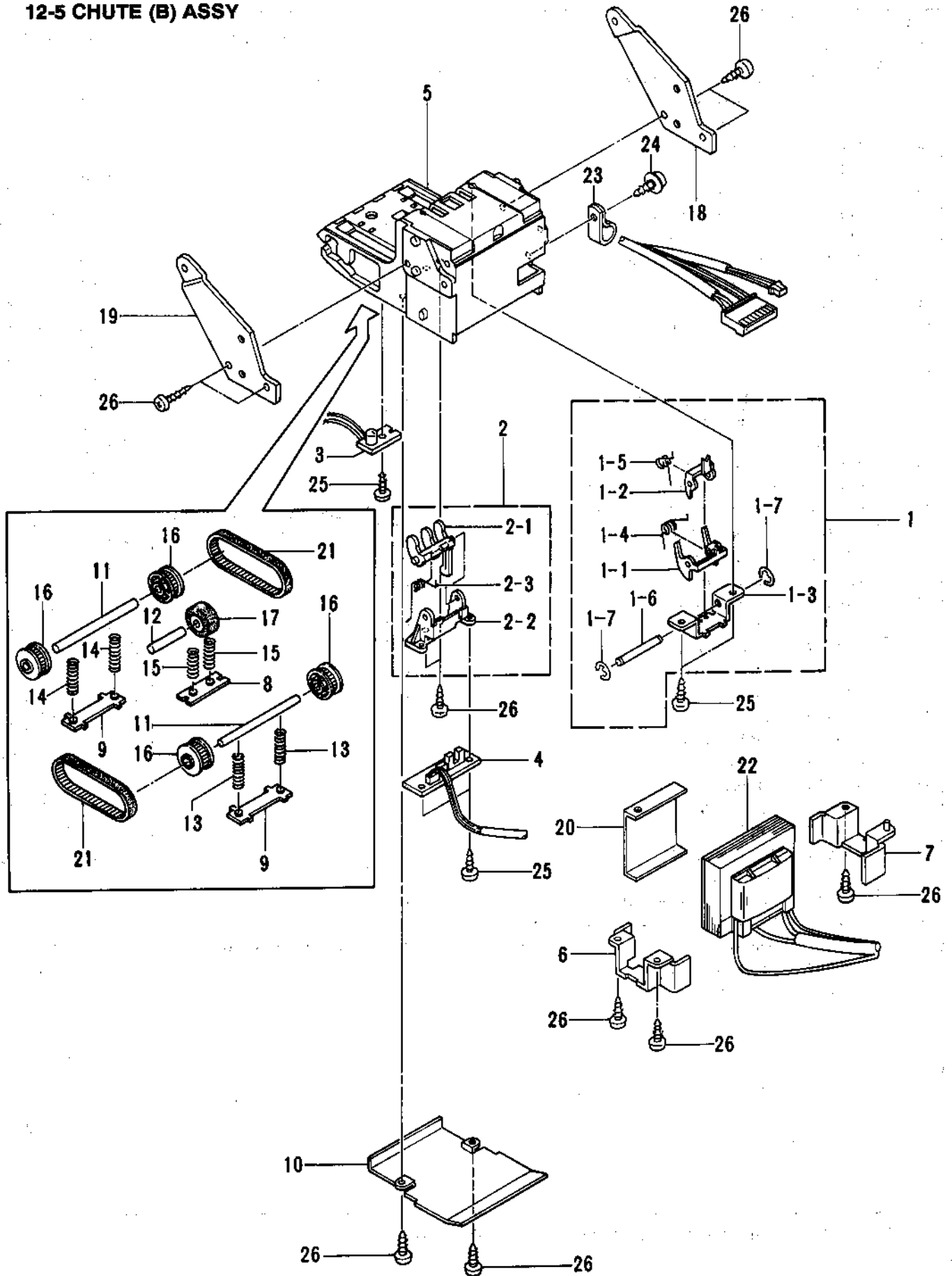

## 12-5 CHUTE (B) ASSY

① 91-3

INDEX NO.	PARTS NO.	DESCRIPTION	Q'TY	REMARKS	A	B	C	D
1	457106	Chute (B) ASSY	1		○	○	○	○
	440957	Lever ASSY (B)	1		○	○	○	○
1-1	440944	Prevention (of hanging) Lever (A)	1		○	○	○	○
1-2	440945	Prevention (of hanging) Lever (B)	1		○	○	○	○
1-3	440946	Prevention (of hanging) Lever Bracket (3)	1		○	○	○	○
1-4	440947	Lever Spring (A)	1		○	○	○	○
1-5	440948	Lever Spring (B)	1		○	○	○	○
1-6	443554	Lever Shaft	1		○	○	○	○
1-7	907403	E-ring $\phi$ 2	2		○	○	○	○
2	457109	Protection (from drawing) Lever ASSY	1		○	○	○	○
2-1	457405	Protection (from drawing) Lever	1		○	○	○	○
2-2	457406	Protection (from drawing) Lever Bracket	1		○	○	○	○
2-3	440554	Protection (from drawing) Lever Spring	1		○	○	○	○
3	457209	LED Board ASSY	1		○	○	○	○
4	457213	Sensor (2) ASSY	1		○	○	○	○
5	457402	Chute (B)	1		○	○	○	○
6	457407	Transformer Bracket	1		○	○	○	○
7	457408	Transformer Bracket (2)	1		○	○	○	○
8	457501	Clamp Plate (A)	1		○	○	○	○
9	457502	Clamp Plate (B)	2		○	○	○	○
10	457503	Bottom Plate	1		○	○	○	○
11	457506	Small Pulley Shaft	2		○	○	○	○
12	457507	Pinch Roller Shaft	1		○	○	○	○
13	457510	Tension Spring (A)	2		○	○	○	○
14	457511	Tension Spring (B)	2		○	○	○	○
15	457512	Tension Spring (C)	2		○	○	○	○
16	412408	Timing Pulley (B)	4		○	○	○	○
17	412418	Pinch Roller	1		○	○	○	○
18	440518	Arm (R)	1		○	○	○	○
19	440519	Arm (L)	1		○	○	○	○
20	440563	Shield Plate	1		○	○	○	○
21	440532	Belt (1)	2		○	○	○	○
22	457101	Transformer Harness ASSY	1		○	○	○	○
23	927014	Nylon Clip	1		○	○	○	○
24	904805	Self Tapping Screw with Washer	1	(+) Pan-head 3 × 8	○	○	○	○
25	904208	Self Tapping Screw (+) Pan-head 3 × 6	5		○	○	○	○
26	904209	Self Tapping Screw (+) Pan-head 3 × 8	11	The same screw as No. 905011	○	○	○	○

12-6 STACKER ASSY

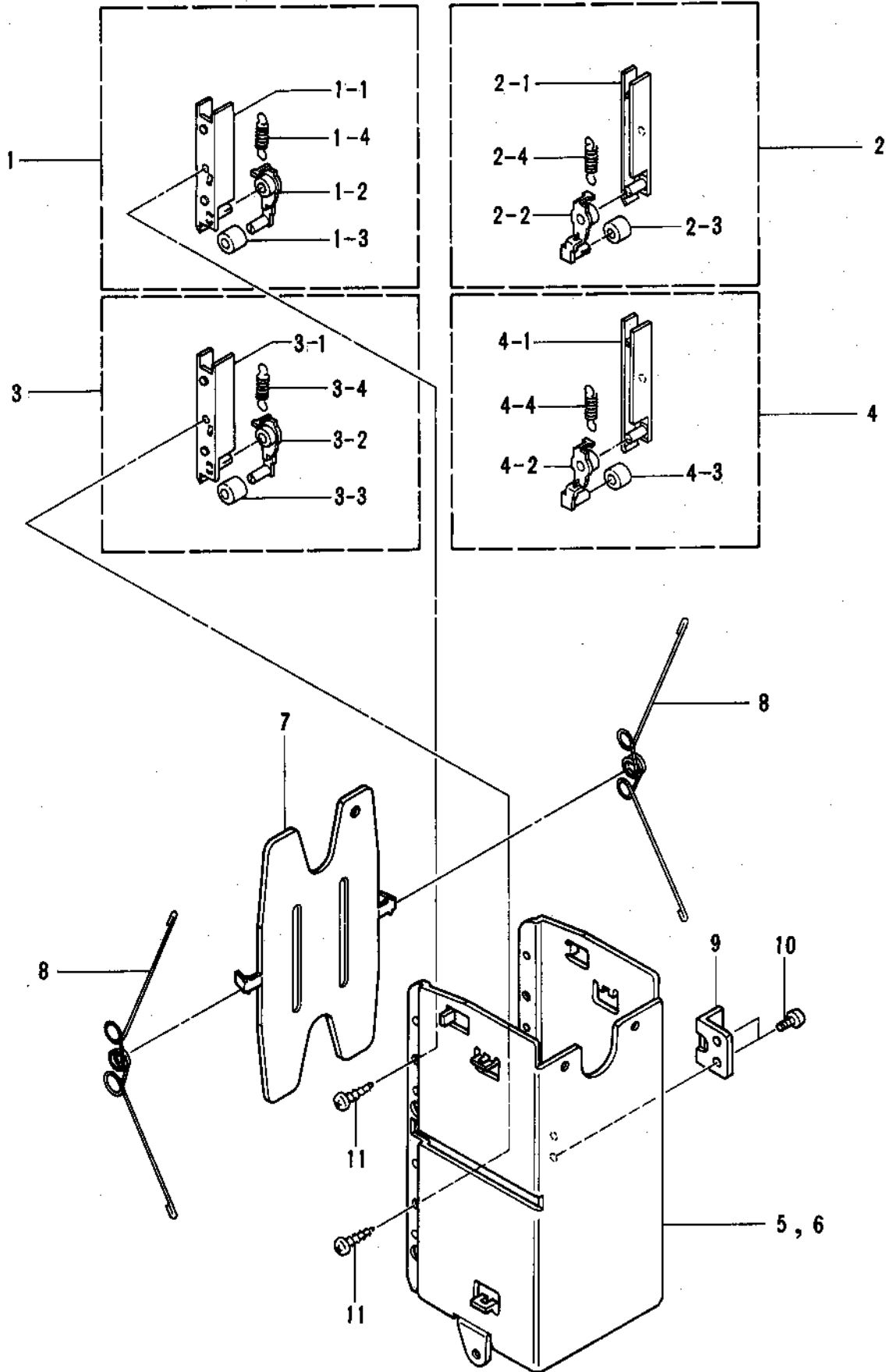



## 12-6 STACKER ASSY

① 91-3

INDEX NO.	PARTS NO.	DESCRIPTION	Q'TY	REMARKS	A	B	C	D
	440704	Stacker ASSY 200	1		○		○	
	440128	Stacker ASSY 400	1			○		○
1	440110	Stack Roller ASSY (1)	1	White	○	○	○	○
1-1	440437	Stack Guide (R)	1	White	○	○	○	○
1-2	440440	Stack Roller Stay (R)	1	White	○	○	○	○
1-3	440441	Stack Roller	1	White	○	○	○	○
1-4	440555	Stack Roller Spring (C)	1		○	○	○	○
2	440111	Stack Roller ASSY (2)	1	White	○	○	○	○
2-1	440438	Stack Guide (L)	1	White	○	○	○	○
2-2	440439	Stack Roller Stay (L)	1	White	○	○	○	○
2-3	440441	Stack Roller	1	White	○	○	○	○
2-4	440555	Stack Roller Spring (C)	1		○	○	○	○
3	440112	Stack Roller ASSY (3)	1	Blue	○	○	○	○
3-1	440475	Stack Guide (R)	1	Blue	○	○	○	○
3-2	440478	Stack Roller Stay (R)	1	Blue	○	○	○	○
3-3	440479	Stack Roller	1	Blue	○	○	○	○
3-4	443560	Stack Roller Spring	1		○	○	○	○
4	440113	Stack Roller ASSY (4)	1	Blue	○	○	○	○
4-1	440476	Stack Guide (L)	1	Blue	○	○	○	○
4-2	440477	Stack Roller Stay (L)	1	Blue	○	○	○	○
4-3	440479	Stack Roller	1	Blue	○	○	○	○
4-4	443560	Stack Roller Spring	1		○	○	○	○
5	440901	Stacker 200	1		○		○	
6	440583	Stacker (G) 400	1			○		○
7	440507	Stacker Plate	1		○	○	○	○
8	440588	Stacker Spring (G)	2		○	○	○	○
9	457410	Safety Switch Lever	1	The same part as No. 440455	○	○	○	○
10	900006	Screw (+/-) Pan-head M3 × 4	2		○	○	○	○
11	904208	Self Tapping Screw (+) Pan-head 3 × 6	4		○	○	○	○

