

1. PRODUCT

VOLVIC WATER 500 ml. SQ PET - 2.41 x 7.98 Long (see Note 5.)

2. PRODUCT CAPACITY

32 PER COLUMN - 72", 40 PER COLUMN - 79"

3.

Product	CAM POSITION	BACK SPACER	GAGE BAR	Sold out Lever	SIDE Spacer		GAGE BAR CLIP	
					LH	RH	Part No.	Position
500 ml Volvic	2	10	2	1083449 SHORT	1115279 LH	1073589 RH	1066112-1	1

4. GAGE BAR CLIP SET UP.

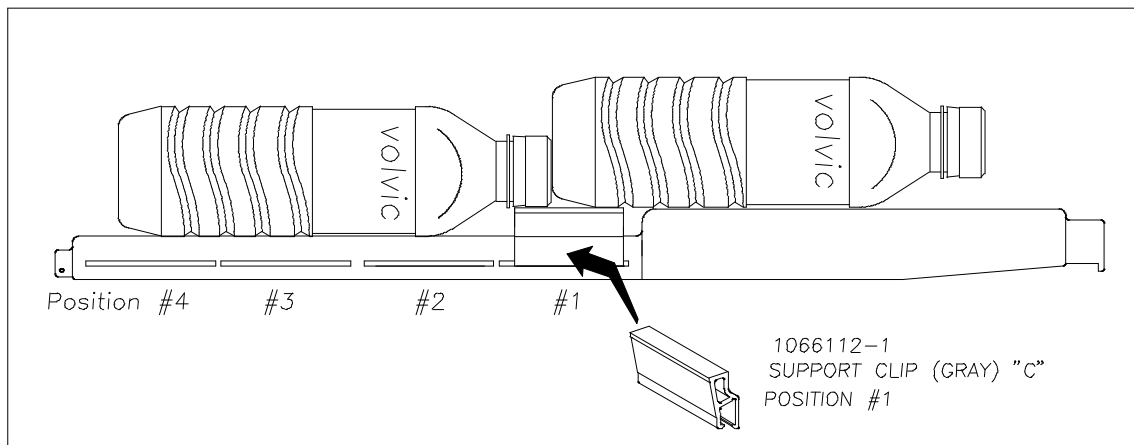

5. SET UP GUIDE.

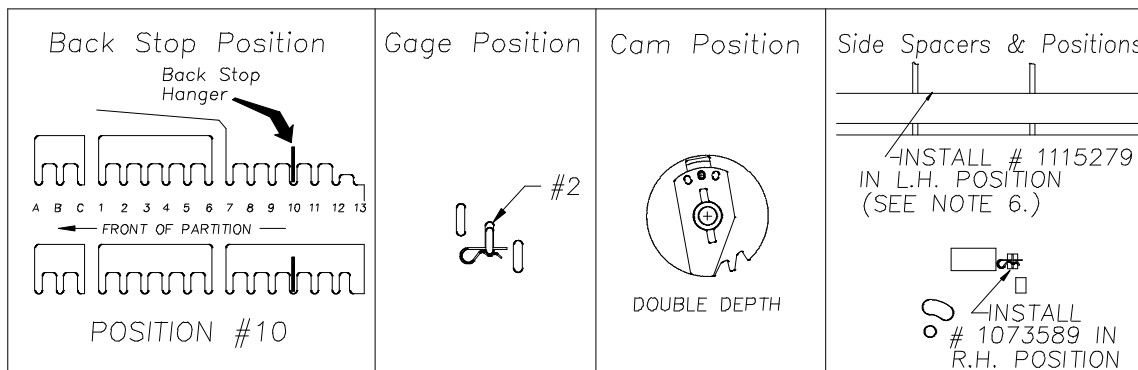

5. Because the bottle is square, it may contact an "A" support clip (black) in the next right column. If the Volvic product hangs there, the clip should be removed.
6. Because of the Load Rack Bracket, the left hand spacer can't be installed in column # 6. Therefore, this product can't be vended in that column.
7. The Sold-out Lever is to be the short style with the long front spacer. The Spring is to be located on the right side (low pressure setting).
8. FOR OTHER PRODUCT SET UP GUIDES, CONTACT THE VENDO COMPANY. TEL: (209) 439-1770. FAX: (209) 439-2083.