

1. PRODUCT

**20 OZ. BOLT COKE CONTOUR - 2.88 top x 2.87 btm x 9.00 Long**

2. PRODUCT CAPACITY

**28 PER COLUMN - 72", 34 PER COLUMN - 79"**

3. SET UP GUIDE UNIVENDOR-2

Product	CAM POSITION	BACK SPACER	GAGE BAR	Sold out Lever	SIDE SHIM	GAGE BAR CLIP	
						Part No.	Position
20 oz BOLT	2	13	1	389242 SHORT	NONE	1066112	1

**Note:** To properly vend 20 oz.Bolt. The Univendor-2 must have the columns setup correctly. Kit # 1077457, longer sold out block will be needed.

4. GAGE BAR CLIP SET UP.

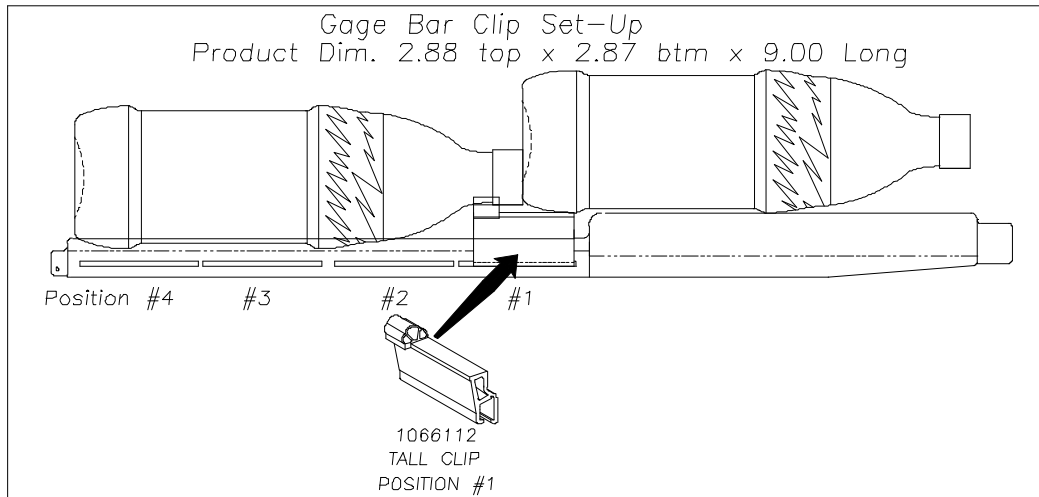

5. SET UP GUIDE.

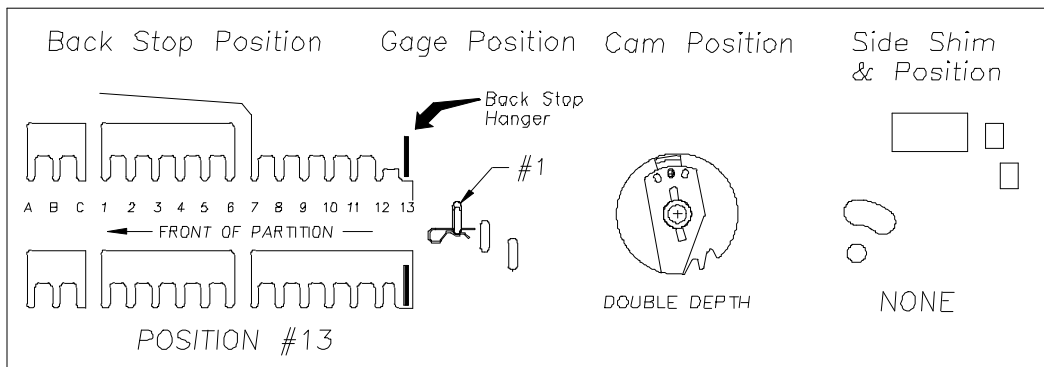

6. SOLD-OUT LEVER TO BE SHORT STYLE WITH FRONT SPACER PN 1077457. SPRING TO BE LOCATED ON THE RIGHT SIDE (LOW PRESSURE SETTING).