

**1. PRODUCT**

**20 OZ. COKE CONTOUR - 2.86 x 8.94 Long**

**2. PRODUCT CAPACITY**

**28 PER COLUMN - 72", 34 PER COLUMN - 79"**

**3. SET UP GUIDE UNIVENDOR-2**

Product	CAM POSITION	BACK SPACER	GAGE BAR	Sold out Lever	SIDE SHIM	GAGE BAR CLIP	
						Part No.	Position
20 oz COKE	2	13	1	389242 SHORT	NONE	1066112	1

**Note:** To properly vend 20 oz.Coke. The Univendor-2 must have the columns setup correctly.

**4. GAGE BAR CLIP SET UP.**

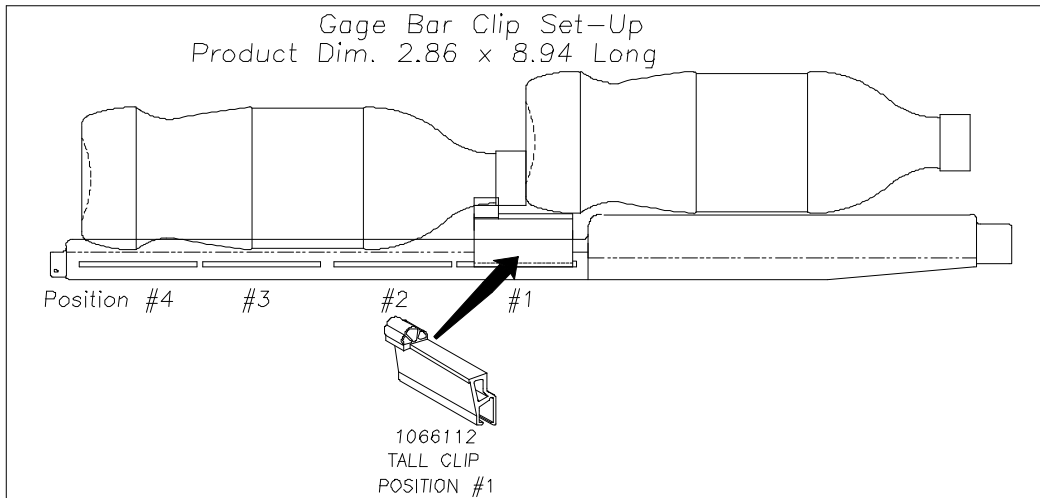

**5. SET UP GUIDE.**

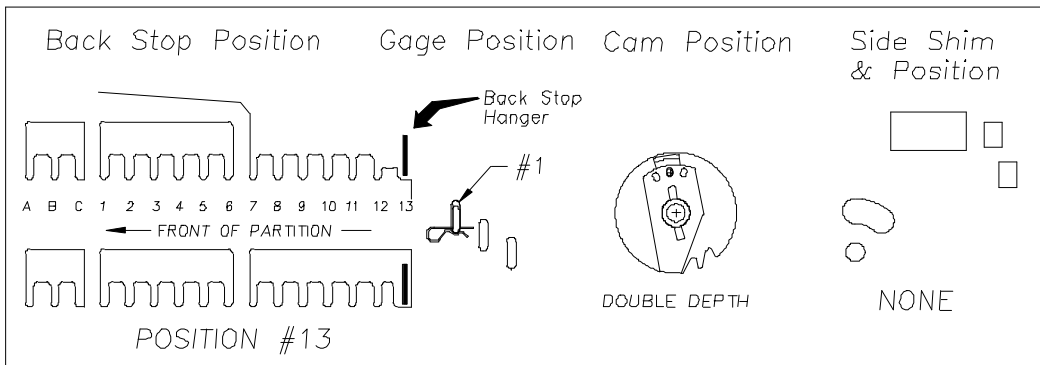

**6. SOLD-OUT LEVER TO BE SHORT STYLE WITH FRONT SPACER.  
SPRING TO BE LOCATED ON THE RIGHT SIDE (LOW PRESSURE SETTING).**