

1. PRODUCT

20 OZ. PEPSI PET 18 SWIRL TOP - 2.86 Top x 2.86 Btm x 8.61 Long

2. PRODUCT CAPACITY

28 PER COLUMN - 72", 34 PER COLUMN - 79"

3. SET UP GUIDE UNIVENDOR-2

Product	CAM POSITION	BACK SPACER	GAGE BAR	Sold out Lever	SIDE	GAGE BAR CLIP	
					SHIM	Part No.	Position
20 oz PEPSI	2	13	1	389242 SHORT	**TWO 1066821	1066112	1

Note: To properly vend 20 oz. Pepsi. The Univendor-2 must have the columns setup correctly.
** two flat shims are optional for the 18 swirl, will not effect the product from vending.

4. GAGE BAR CLIP SET UP.

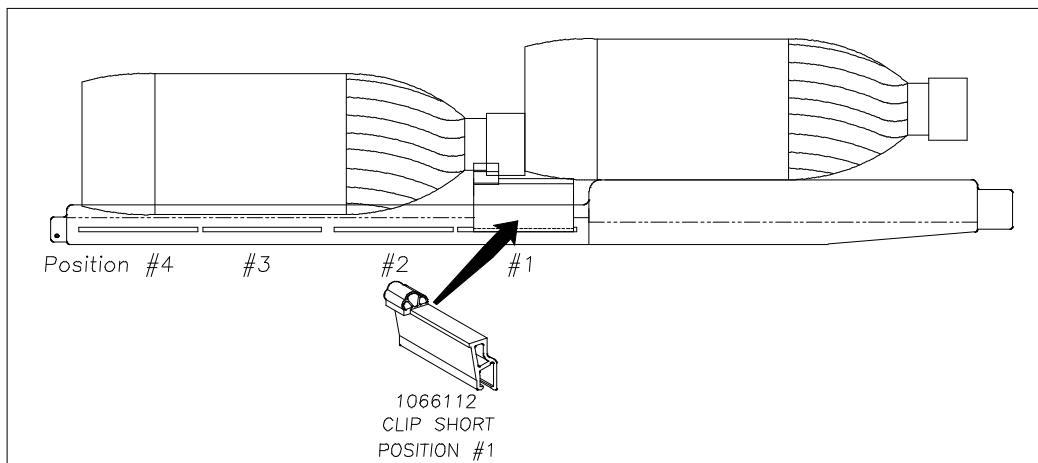

5. SET UP GUIDE.

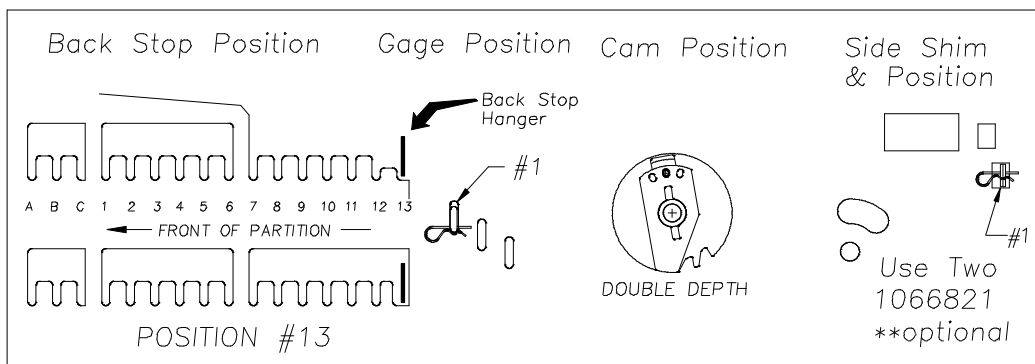

6. SOLD-OUT LEVER TO BE SHORT STYLE WITH NEW FRONT SPACER #1077457. SPRING TO BE LOCATED ON THE RIGHT SIDE (LOW PRESSURE SETTING).

**7. FOR OTHER PRODUCT SET UP GUIDES CONTACT VENDO COMPANY.
TEL: (209) 439-1770 FAX: (209) 439-2083.**