

1. PRODUCT

16 OZ. VERYFINE CHILLERS PET BOTTLE - 2.80 x 7.20 Long

2. PRODUCT CAPACITY

28 PER COLUMN - 72", 34 PER COLUMN - 79"

3. SET UP GUIDE UNIVENDOR-2

Product	CAM POSITION	BACK SPACER	GAGE BAR	Sold out Lever	SIDE SPACER	GAGE BAR CLIP	
						Part No.	Position
16 OZ Chillers	2	8	2	389242 SHORT	TWO 1074465	1066112-1	1

Note: To properly vend Chillers 16oz. The Univendor-2 must have the columns setup correctly. Some product will be damaged out of the box and cause jamming, the bottom of the product will be flat or dented in some places, please discard.

4. GAGE BAR CLIP SET UP.

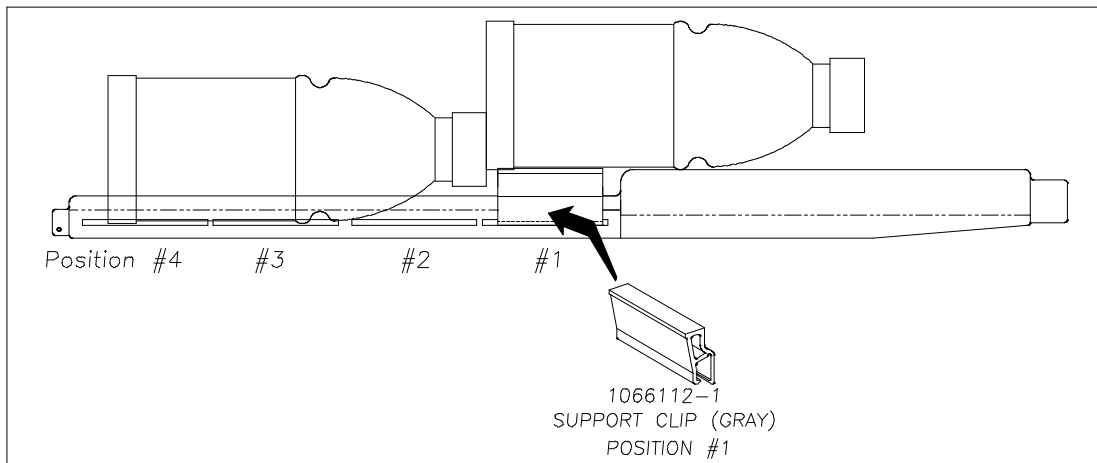

5. SET UP GUIDE.

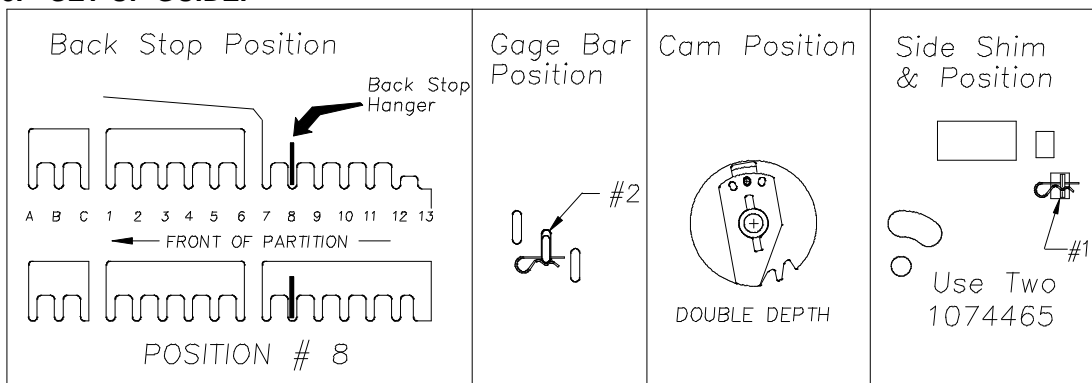

6. SOLD-OUT LEVER TO BE SHORT STYLE WITH NEW FRONT SPACER #1077457. SPRING TO BE LOCATED ON THE RIGHT SIDE (LOW PRESSURE SETTING).

7. FOR OTHER PRODUCT SET UP GUIDES CONTACT THE VENDO COMPANY. TEL: (209) 439-1770 FAX: (209) 439-2083.