



The Premium Collection

Ambient and Refrigerated models

SERVICE and PARTS MANUAL



700 Seaga Drive, Freeport, IL 61032, U.S.A. visit: seagamfg.com email: info@seagamfg.com

INTRODUCTION

Congratulations on the purchase of your vending machine. This vending machine has been designed to give you many years of dependable service. It requires little maintenance and is easy to set up and operate.

READ THIS MANUAL COMPLETELY

Your vending machine is designed to operate simply and reliably, but to take full advantage of your vendor, please read this owner's manual thoroughly. It contains important information regarding installation and operations, as well as a brief trouble-shooting guide.

EQUIPMENT INSPECTION

After you have received your vendor and have it out of the box, place it on a secure surface for further inspection. **Note:** Any damages that may have occurred during shipping must be reported to the delivery carrier immediately. Reporting damages and the seeking of restitution is the responsibility of the equipment owner. The factory is willing to assist you in this process in any way possible. Feel free to contact our Customer Care Department with questions you may have on this process.

It is important that you keep the original packaging for your vending machine at least through the warranty period. If your machine needs to be returned for repair, you may have to purchase this packaging if it is not retained.

Once you have your vendor located, we suggest that you keep this manual for future reference, or you can view this manual online at www.seagamfg.com. Should any problems occur, refer to the section entitled "COMMON QUESTIONS AND ANSWERS". It is designed to help you quickly identify a problem and correct it.



For Service and Customer Care in the US:
8:30 a.m. - 4:00 p.m. CST. Mon thru Fri
815.297.9500 ext 160
815.297.1758 Fax
email: customercare@seagamfg.com

For Service and Customer Care in Europe:
9:00 a.m. - 5:30 p.m. Mon thru Fri
+44(0)1132 434266
+44(0)113 246 7525 Fax
email: info@seaga.co.uk

Seaga Manufacturing, Inc.
700 Seaga Drive
Freeport, IL 61032 U.S.A.
seagamfg.com

Seaga UK Ltd.
Leeds, UK
seaga.co.uk

US Version, 110 V

| Specifications | 4 Wide | | | 5 Wide | | |
|--------------------|------------------|------------------------|------------------------|------------------|------------------------|------------------------|
| | SP432 Ambient | SP430D Refrigerated | SP735R Refrigerated | SP540 Ambient | SP536D Refrigerated | SP536R Refrigerated |
| Height | 72" | 72" | 72" | 72" | 72" | 72" |
| Width | 35" | 35" | 35" | 39" | 39" | 39" |
| Depth | 37" | 37" | 37" | 37" | 37" | 37" |
| Floor Space | 8.75 Sq. Ft | 8.75 Sq. Ft. | 8.75 Sq. Ft. | 9.75 Sq. Ft. | 9.75 Sq. Ft. | 9.75 Sq. Ft. |
| Packing Size | 56.27 Cu. Ft. | 56.27 Cu. Ft. | 56.27 Cu. Ft. | 62.53 Cu. Ft. | 62.53 Cu. Ft. | 62.53 Cu. Ft. |
| Voltage (AC) | 110V | 110V | 110V | 110V | 110V | 110V |
| Hertz | 60Hz | 60Hz | 60Hz | 60Hz | 60Hz | 60Hz |
| Running Amperes | 1Amp. | 8Amp. | 8Amp. | 1Amp. | 8Amp. | 8Amp. |
| Watts | 300 Watts | 750 Watts | 750 Watts | 300 Watts | 750 Watts | 750 Watts |
| Refrigerant Type | - | 134a | 134a | - | 134a | 134a |
| Refrigerant Charge | - | 300 Grms. | 300 Grms. | - | 300 Grms. | 300 Grms. |
| Shipping Weight | 470 lbs. | 703 lbs. | 698 lbs. | 528 lbs. | 764 lbs. | 721 lbs. |

UK Version, 220 V

| Specifications | 4 Wide | | | 5 Wide | | |
|--------------------|------------------|------------------------|------------------------|------------------|------------------------|------------------------|
| | SP432 Ambient | SP430D Refrigerated | SP735R Refrigerated | SP540 Ambient | SP536D Refrigerated | SP536R Refrigerated |
| Height | 183 cm | 183 cm | 183 cm | 183 cm | 183 cm | 183 cm |
| Width | 89 cm | 35" 89 cm | 89 cm | 99 cm | 99 cm | 99 cm |
| Depth | 93 cm | 93 cm | 93 cm | 93 cm | 93 cm | 93 cm |
| Floor Space | 0.812 S Mtr | 0.812 S Mtr | 0.812 S Mtr | 0.905 S Mtr | 0.905 S Mtr | 0.905 S Mtr |
| Packing Size | 1.59 Cu Mtr | 1.59 Cu Mtr | 1.59 Cu Mtr | 1.77 Cu Mtr | 1.77 Cu Mtr | 1.77 Cu Mtr |
| Voltage (AC) | 220V | 220V | 220V | 220V | 220V | 220V |
| Hertz | 50Hz | 50Hz | 50Hz | 50Hz | 50Hz | 50Hz |
| Running Amperes | 1Amp. | 5Amp. | 5Amp. | 1Amp. | 5Amp. | 5Amp. |
| Watts | 300 Watts | 750 Watts | 750 Watts | 300 Watts | 750 Watts | 750 Watts |
| Refrigerant Type | - | 134a | 134a | - | 134a | 134a |
| Refrigerant Charge | - | 350 Grms. | 350 Grms. | - | 350 Grms. | 350 Grms. |
| Shipping Weight | 317 kg | 319 kg | 317 kg | 239 kg | 347 kg | 327 kg |

PHYSICAL CHARACTERISTICS

- Finish : Powder Coat paint
- Number of Trays : 6 Standard

ENVIRONMENT

- Location Environment: Indoors only

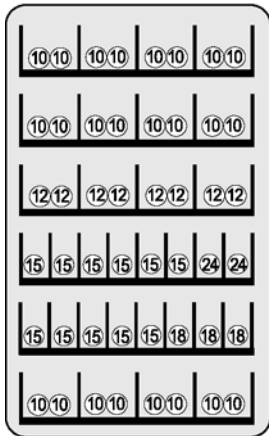
ELECTRICAL REQUIREMENT

US version requires one (1) 120 VAC 12 Amps grounded outlet.
 UK version requires one (1) 220 VAC 12 Amps grounded outlet.

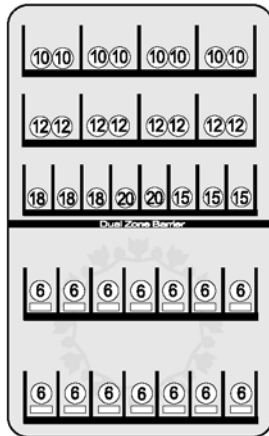
STANDARD COIL CONFIGURATION

Subject to change without notice.

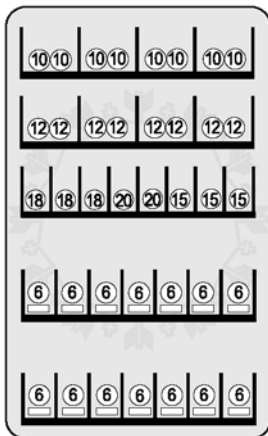
SP432



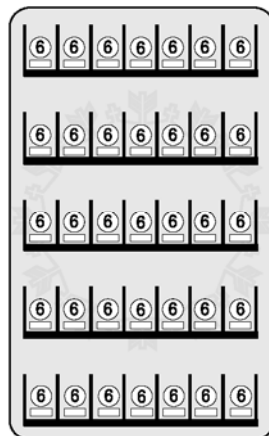
SP430D



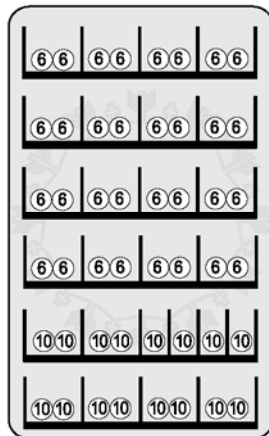
SP430R



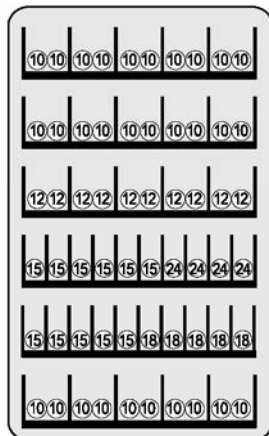
SP735R



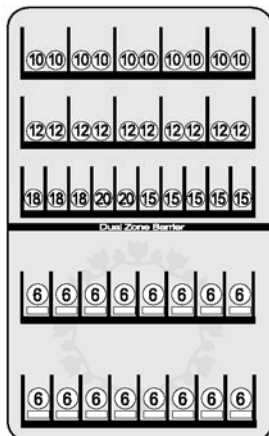
SP426F



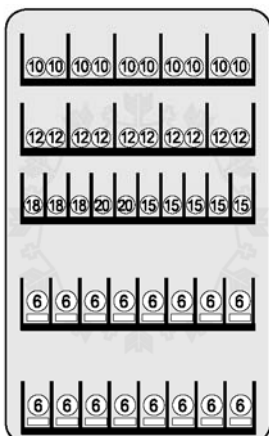
SP540



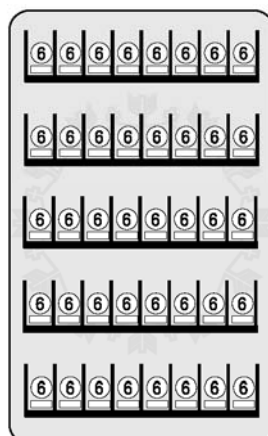
SP536D



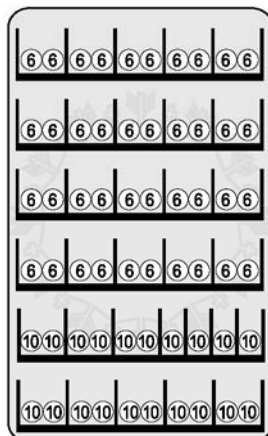
SP536R



SP840R



SP532F



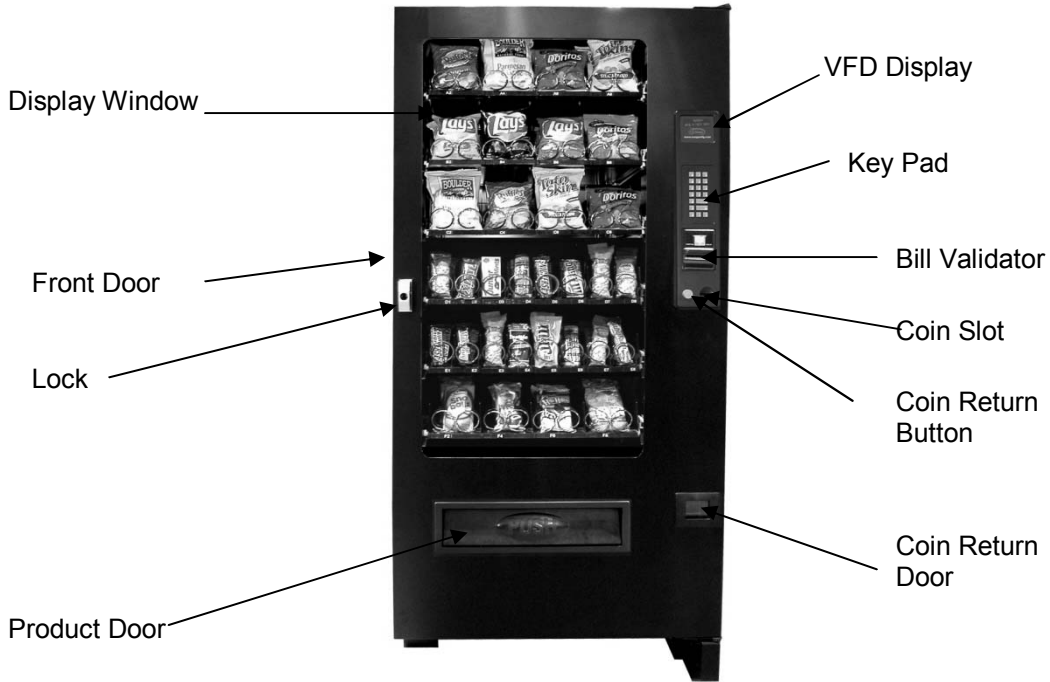
CAUTION: Certain procedures described in this manual require that voltage be on in the machine. Only trained personnel should perform these functions. Use extreme caution while performing the procedures marked with the voltage symbol shown here:



CAUTION: Certain procedures described in this manual require a qualified, trained technician to perform the particular task at hand. These procedures will be marked with the attention symbol shown here:

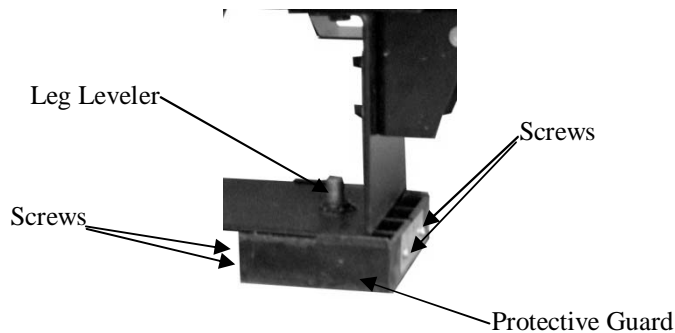


Fig. 1 - Exterior View (SP432 4-Wide Snack Machine Shown)



Protective shipping guards (Fig. 2) were installed on the leveling legs at the factory. Once the machine is placed near its final location the protective shipping guards may be removed. To remove the shipping guard, unscrew the leveling leg from the bottom until the guard is loose – a few turns only. The guard is held together with four phillips head screws and two brackets. Remove the screws and the guard will split in half for removal.

Fig. 2 – Shipping Guards



Now place the machine into its final location. Using a level on the top of the machine, adjust the five leveling legs, if necessary, for proper level both side to side and front to back. A good point to keep in mind is the shorter the leveling legs are kept to achieve proper leveling, the more stable the machine will be.

Proper leveling is also necessary to allow easy opening and closure of the vending machine door and to insure proper vending operation.

Fig. 3 - Leg Levelers

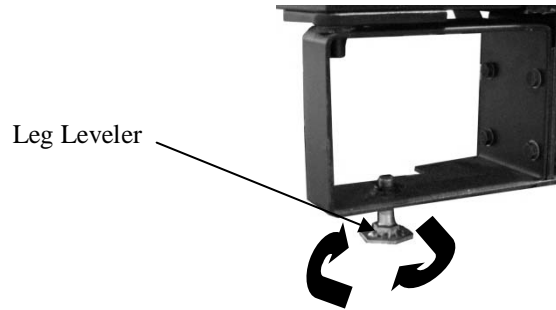
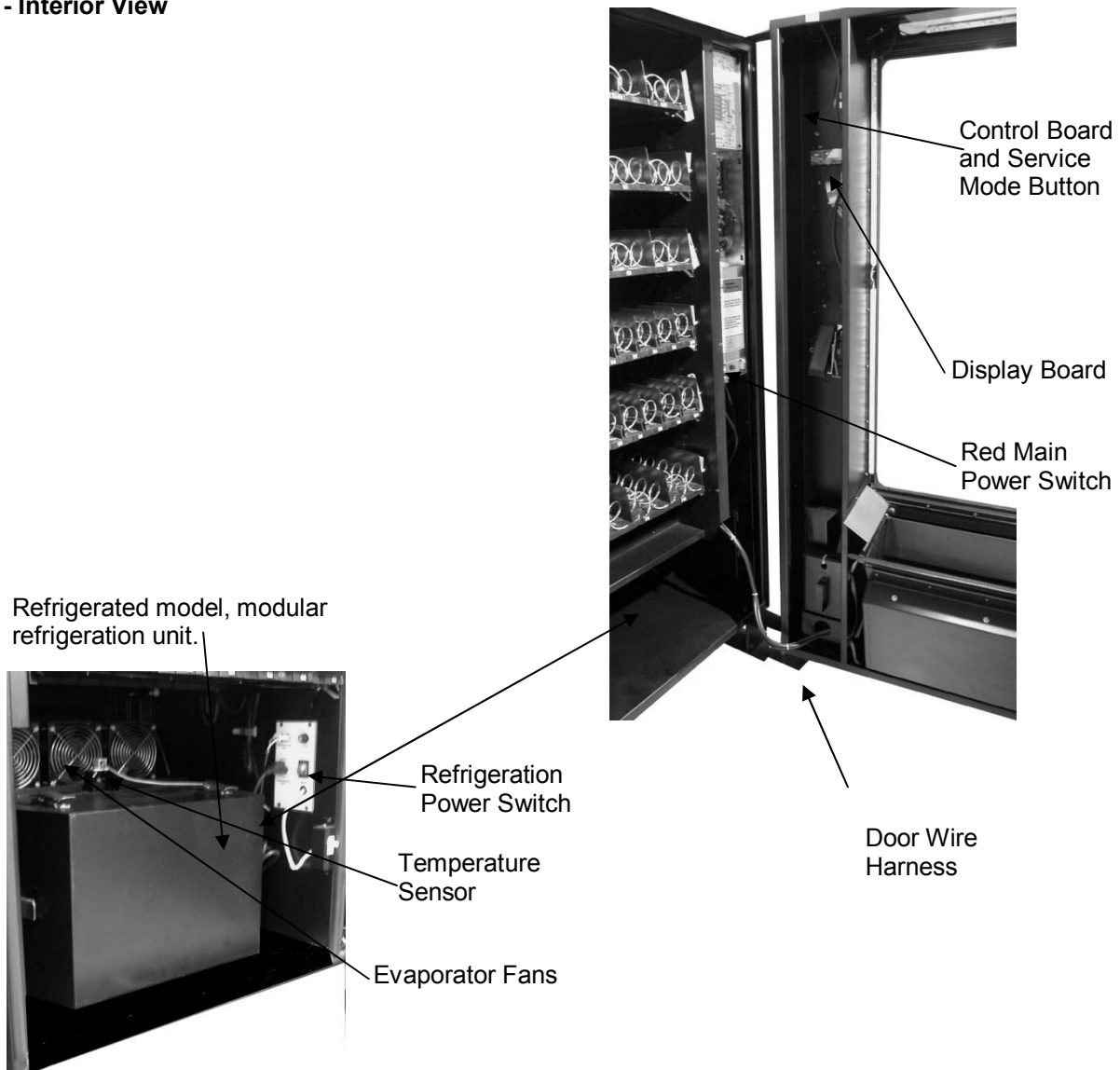


Fig. 4 - Interior View



CAUTIONS**Your vendor is intended for indoor use only.**

Your vendor must be set on a level, well-supported location.
Always unload vendor before transporting it.
Remove all wire ties and protective sheeting prior to vending.

**CAUTION!**

Procedures marked in this manual with the symbol shown to the left require power to the machine, which means that there is a shock hazard.

**CAUTION!**

It is important that this machine is hooked up to the proper voltage. Verify the voltage before connecting the machine to a wall outlet.

**CAUTION!**

Different countries may have different power arrangements. Insure that the machine is properly grounded before operating.

**CAUTION!**

If the power cord is damaged, it must be replaced by the manufacturer, authorized service agent or a similarly qualified person to avoid electrical hazards.

**ATTENTION!**

This vending machine is very heavy. Ensure that sufficient personnel are available for lifting or transporting the machine. Use proper lifting procedures and equipment.

**CAUTION!**

Certain components of this machine are sensitive to static electricity. Precautions for handling sensitive devices should be observed when handling these items.

**ATTENTION!**

Refrigerated models need air flow. Leave at least 6" between the back of the vending machine and the wall. Condenser cooling air is taken in the bottom and exhausted out the back of the machine. Clean the condenser once every two weeks or more often for high-particle locations.

DOOR CLEARANCE

Please leave 7" clearance on the right side of the machine for the door to open and extend past the cabinet side. See clearance requirements above for refrigerated units.

LOADING PRODUCTS

To present your product in as an attractive and professional manner as possible, do not load any damaged items, and make sure items are facing forward for easy identification by your customer.

Note: The size of the item being vended must be larger than the Helix Coil, but smaller than the Product Column to vend correctly. Never force an oversized item into the Helix Coil or Product Column, nor attempt to vend an item that is smaller than the Helix Coil as this will create problems and deter customers. (Fig.5)

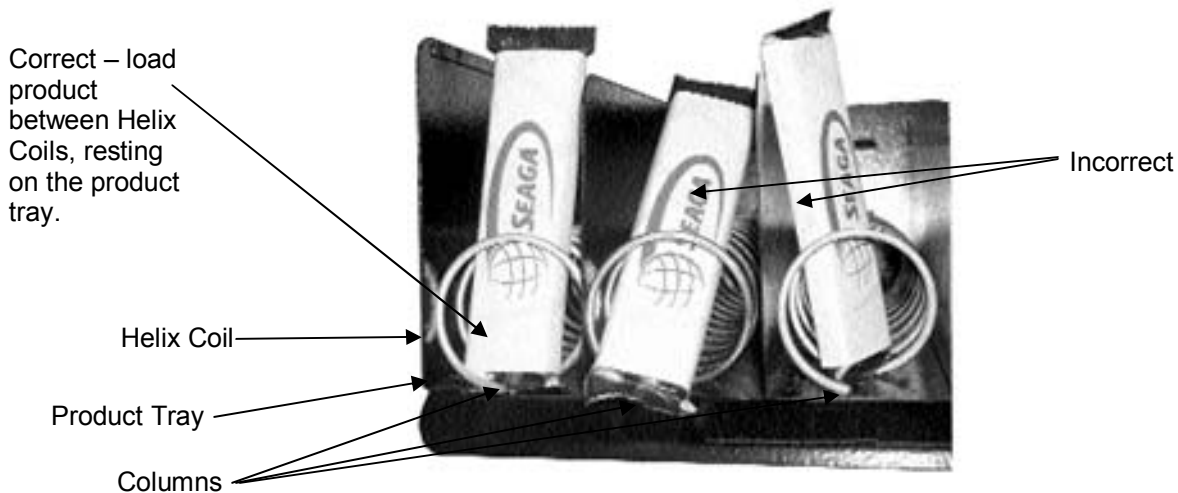
1. To Load Product:

- A.) Use the release latches and pull the desired Product Tray all of the way forward. Product Tray will tilt down or can be removed and placed on the floor or a table.
Note: Pull out only one (1) Product Tray at a time.
- B.) Place product in proper size Helix Coil. Note: Bottom of product must rest on the Product Tray and not on the Helix Coil. (Fig. 5) Load each Product Chute from front to back. Note: Do not leave any spaces between items.
- C.) Once Product Tray is loaded, lift the front of the tray to level and push it back in. Repeat above steps until all Product Trays are fully loaded.
- D.) After loading the product, if you have removed the tray to do so, place the Tray in the cabinet by aligning the wheels in the guide rails. Clear the wire harness To the side so that it is not interfering with the tray below.

To increase the length of the Helix Coil, white plastic Product Pushers can be snapped on the end. A supply of Product Pushers is provided in the hardware envelope.

Note: We suggest that you always partially fill the vendor with product and perform at least five (5) test vends. Test vends can be performed easily by entering Service Mode and running "Individual Motor Testing". (See: Keypad and LED Display, Individual Motor Testing.)

Fig. 5 – Loading Helix Coils



PRODUCT PUSHERS

Product pushers assist in moving the top of the product forward while it is being vended on the bottom, helping it fall smoothly from the shelf. Product pushers are also good for products that have the wrapper flaps on the ends of the package. Packaging such as this benefits from the extra momentum from the product pushers to keep the flaps from hanging up the product on the spiral. The pusher is installed approximately ½ inch from the end of the coil with the tab extending forward (see Fig. 6). Locate the pusher in its proper position, hold it against the coil wire and push the semi-circular part around the coil wire. Note: Boxed items will not need a product pusher.

Figure 6 – Product Pusher Installation



LOADING BAGGED OR BOXED ITEMS

When vending small bagged items in the 8 or 10 selection trays can be a problem when the products are not loaded properly. The flap edges of some products may get trapped under the spiral and cause the product to “hang up”. It is recommended that the bottom flap of this type of packaging be folded forward and up (Fig. 5) next to the product when loading. This type of packaging also lets the product settle to the bottom, so using the wider spirals is also recommended.

LOCK

Your vendor has one Lock, more commonly known as T-handle lock. To unlock the front door, insert key and turn clockwise $\frac{1}{4}$ turn. When unlocked the ‘T’ of the Lock will pop out from its base. Turn the ‘T’ 15 to 20 times counter clockwise to unlock the door. To Lock the door turn the ‘T’ handle clockwise 15 to 20 times and then push the ‘T’ inside the Lock to lock the door. Key can now be removed. Note: Do not over-tighten when locking – this could strip the threads and damage your machine.

REFRIGERATION

If you purchased a refrigerated model, please see special information throughout the manual regarding refrigeration, settings and other information. The refrigeration system consists of Compressor, Relay circuit, Accumulator, condenser, condenser fan, evaporator, evaporator fans and air duct. The entire refrigeration system is modular and has a separate internal power cord, which is plugged in on the plug point provided at the bottom area below the last tray. The power switch has to be turned ON in order to start up the refrigeration system. There is a door switch that controls the refrigeration system ON and OFF condition. When the door is opened, the door switch is not depressed and the refrigeration system shuts OFF. When the door is closed, the switch is activated and the evaporator fans starts turning. There will be a delay before compressor starts running after the door closure.

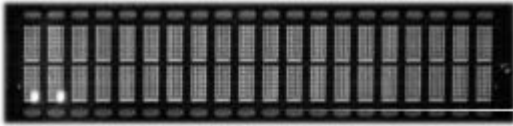
There is a vent on the cabinet back to blow the air from condenser. The inlet vent is at the bottom of the cabinet in front of the condenser. The condenser has to be cleaned regularly. The recommended frequency is once every two weeks. There are 2 clips around the front of the refrigeration module that has to be un-hooked in order to remove the front door of the refrigeration module. This will provide the access to the condenser. Using a vacuum cleaner or a brush, clean the lint in between the condenser fins. Note: Be careful not to bend the fins – this could restrict airflow and damage your machine.

The compressor and the relay circuit, condenser fan motor and drain pan can be accessed in the same manner by removing the front door. The refrigeration system has to be unplugged and the module has to slide completely outside in order to gain access to these components.

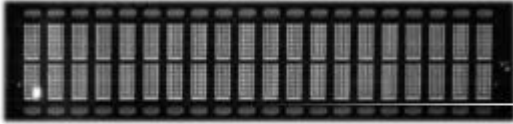
REFRIGERATION STATUS DISPLAY

Use the “10” key on the Keypad to display the following indications of the refrigeration system on the VFD Display:

Figure 7 – Refrigeration Indicators on VFD Display



Delayed Start Mode – door switch is not being engaged; compressor will not start in this mode.



Cooling Mode – Door switch is engaged and compressor is active. The machine is cooling but not yet at operating temperature.



Defrost Mode – Machine is in defrost cycle. Defrost cycle time can be set using the Advance menu option Auto-Defrost in Diagnostics.



Zone 1: Zone 1 is active on the machine. Your SP series machine should only use Zone 2. Shut off Zone 1 in the diagnostics mode using the Advanced submenu.



If there are no indicators on the display, the machine is at the operating temperature.

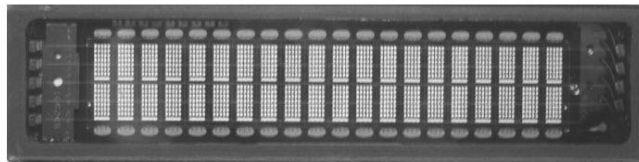
SECTION 3

OPERATION

DISPLAY

The VFD Display (Fig. 8) is a two line, 20 character text display panel located on the front of your vending machine. The display shows the customer the amount of money entered into the vendor and the cost of their selection among other information as programmed. It shows the operator the Service Mode functions for setting the various functions of the vendor.

Fig. 8 – VFD Display



SERVICE MODE



Navigation of the Service Mode Menu

| BUTTON | FUNCTION |
|-----------------|--|
| ↑ Button | This key is used to increase a numeric value, or move forward through the various service mode functions. |
| ↓ Button | This key is used to decrease a numeric value or move backwards through the various service mode functions. |
| F Button | This key is used to confirm, accept, or ENTER into a service mode function. |
| G Button | This key is used to EXIT the service mode or a service mode function. |

Entering Service Mode

To enter into service mode, open the vendor door and Press the Menu Service Mode Button (Fig. 10). After pressing the Service mode switch the controller will beep twice and the display will change to show **“Service Menu”** on the first line and **“Prices”** on the second line (Fig. 10). At this time you can use the keypad on the front of the machine to move through the various service mode MENUS.

Fig. 9 - Service Mode Button

MENUS Service Mode
Button

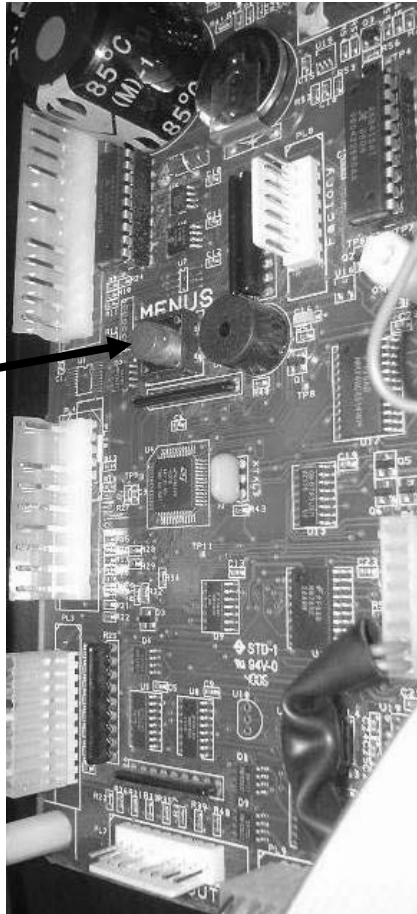


Fig. 10 – VFD Display while in Service Mode. The Prices menu is the first sub-menu.



Exiting service mode

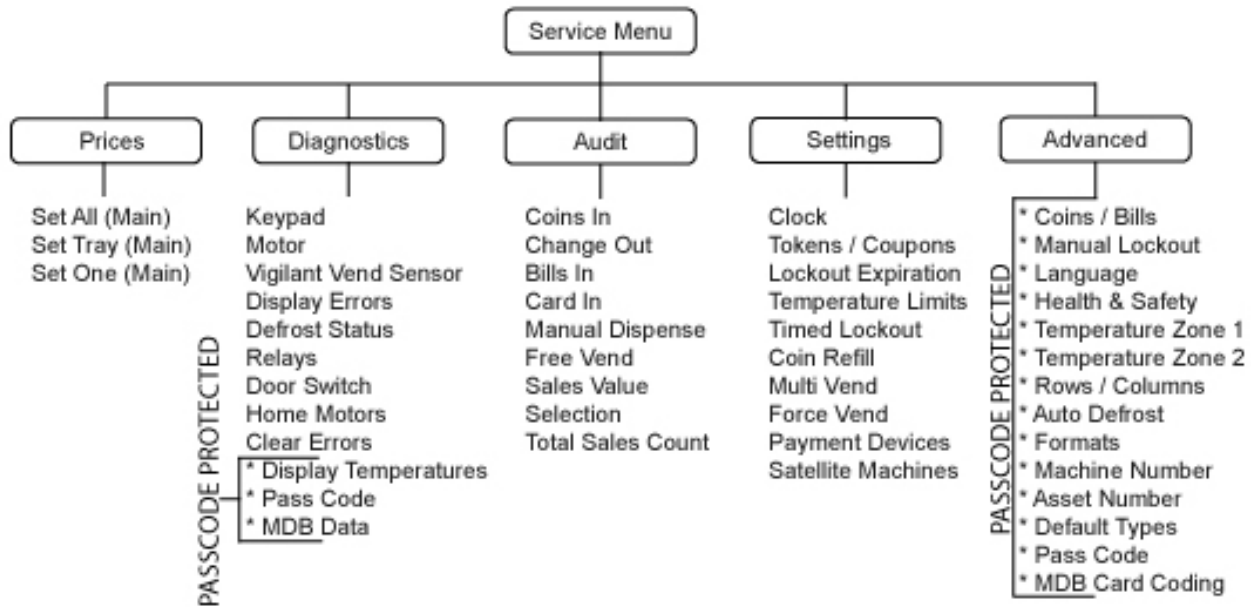
The controller will remain in service mode as long as the user keeps using the keypad to move through the various service mode MENUS. The controller will automatically exit service mode and return to sales mode if any of the following occur:

- 1) The user is inactive for more than 1 minute
- 2) The user presses the EXIT key (G).

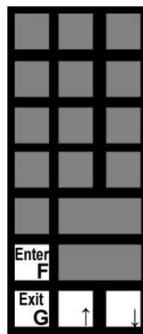
After exiting the service mode, the installed firmware version shows on the display for three seconds, then the controller will revert to sales mode.

Service mode MENUS

The chart below shows the sub-menus while in Service mode:



In the following instructions, refer to the drawing of the four button navigation key drawing on the left side of the page. Follow the arrows, paying attention to the navigation instructions (F), (G), (↑) and (↓)

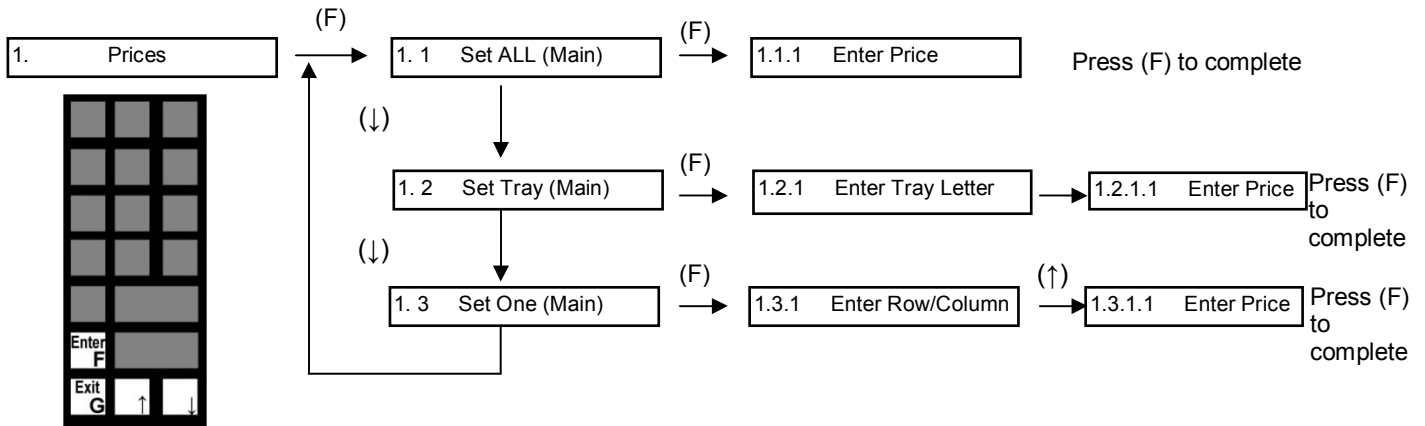


PRICES SUB-MENU

The Prices sub-menu allows you to set prices in three different ways – Set ALL, Set ONE, Set Tray. Set ALL will allow you to set all of selections in the machine to the same price. Set ONE will allow you to set one individual selection of your choosing. Set Tray will allow you to set an entire tray to the same price.

Using these available options will save you time – if the majority of your price is, for example, set at \$1, use the Set ALL sub-menu to set all prices to \$1. You can then go back and set individual prices for certain selections as needed.

In order to enter the price, Press the corresponding number. For example, if the Price of a Selection is \$0.75, then Press “7” and “5”. Press F to accept the value; G to exit to the main menu. *Note: Discount prices can only be set using a Seaga Smart Card.*



DIAGNOSTICS SUB-MENU

Diagnostics - The Diagnostics menu is used to test various features of the machine. Certain critical features of the machine are protected by a pass code provided to the operator to prevent inadvertent modifications to the machine.

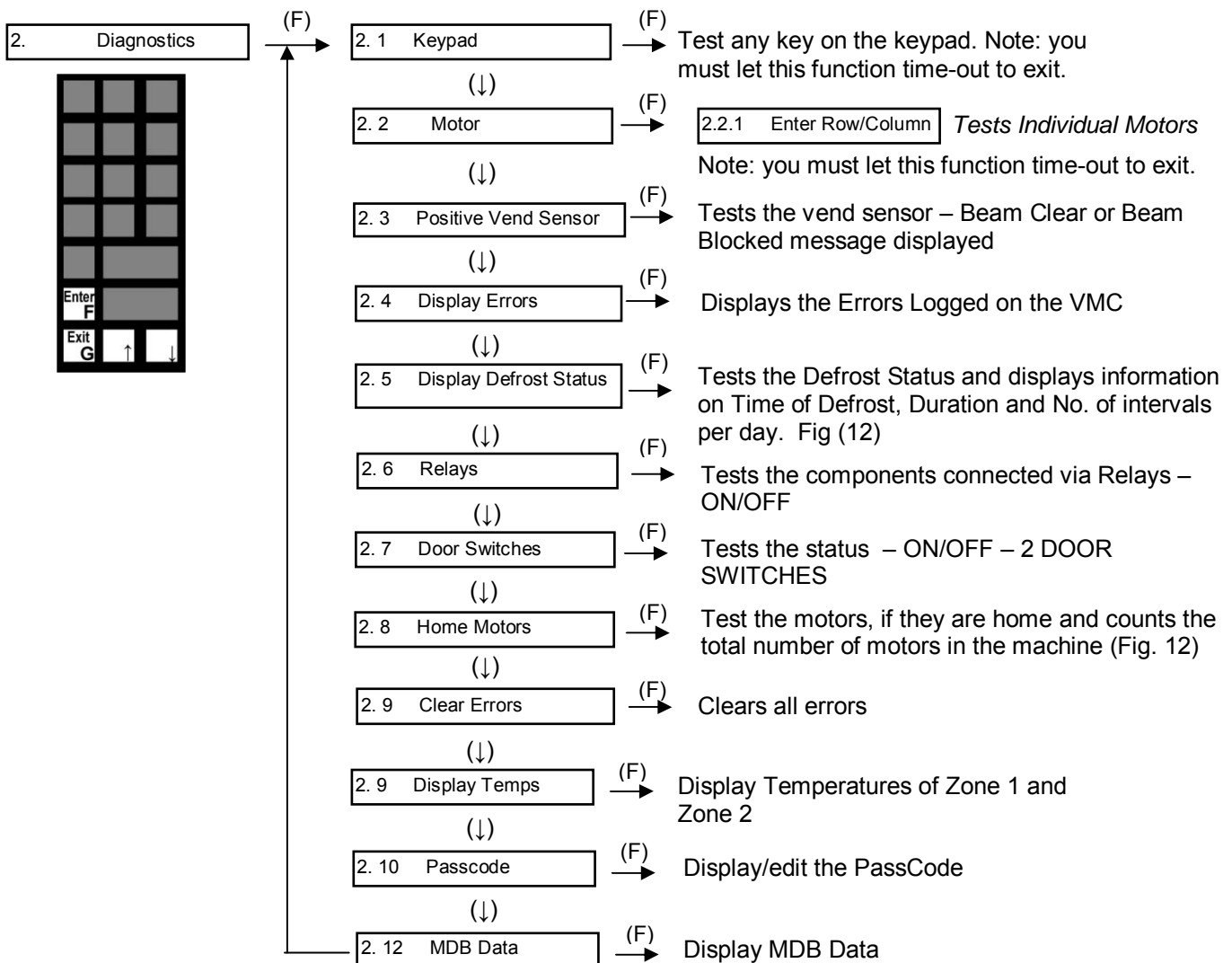


Fig. 11

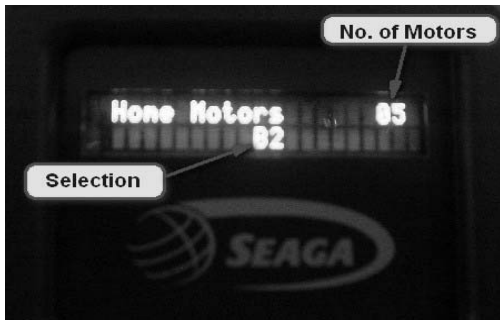
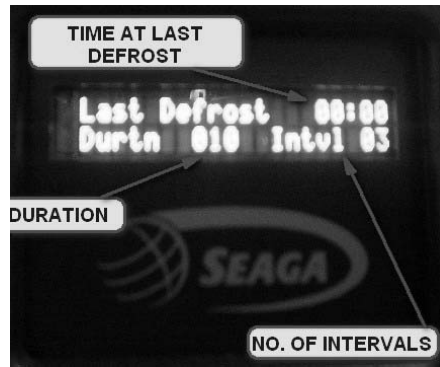
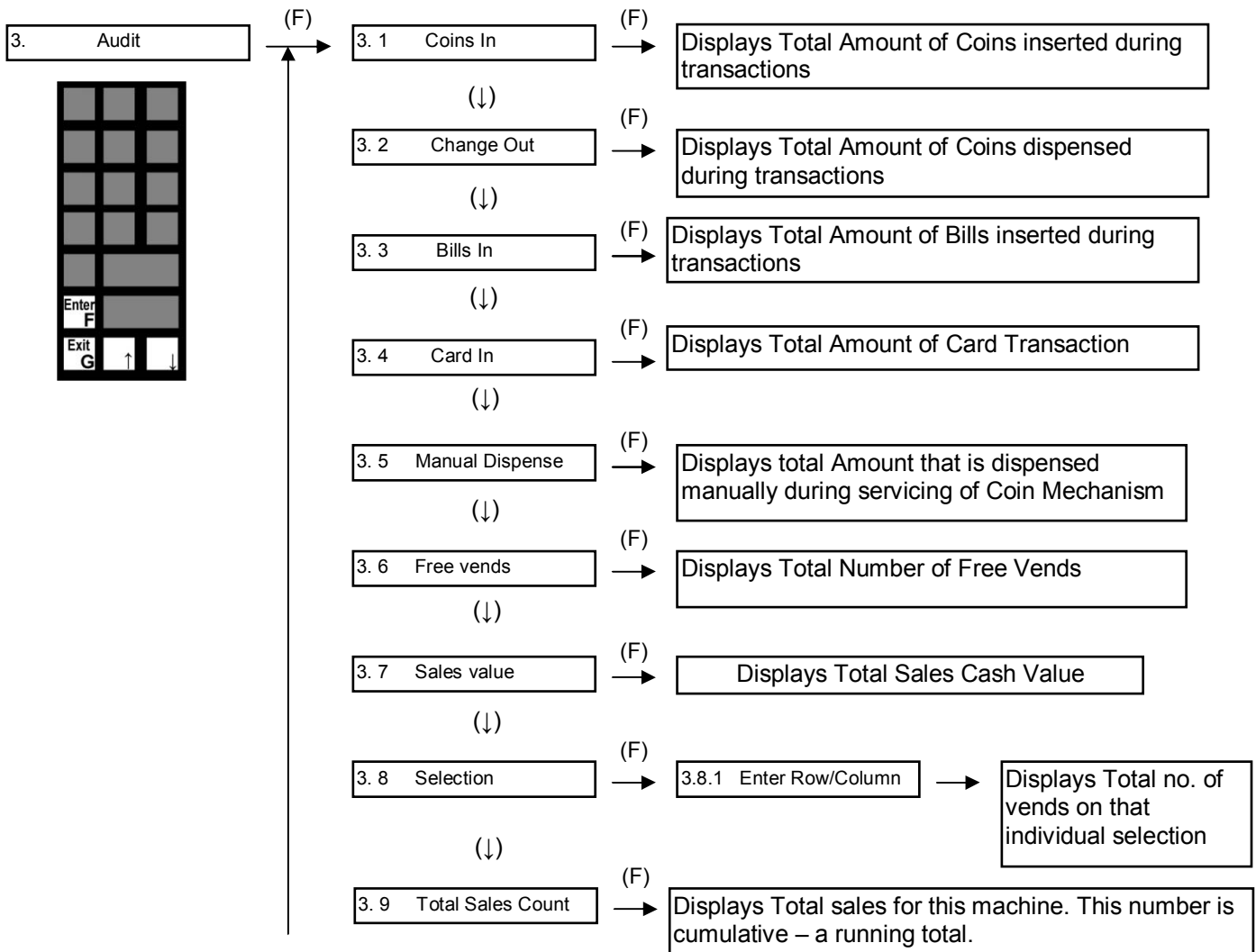


Fig. 12



AUDIT SUB-MENU

AUDIT MENUS -The Audit Menu is used to track the machine operation in all aspects but not limited to the transactions.



SETTINGS SUB-MENU

SETTINGS - This menu is used to Setup the features of the machine.

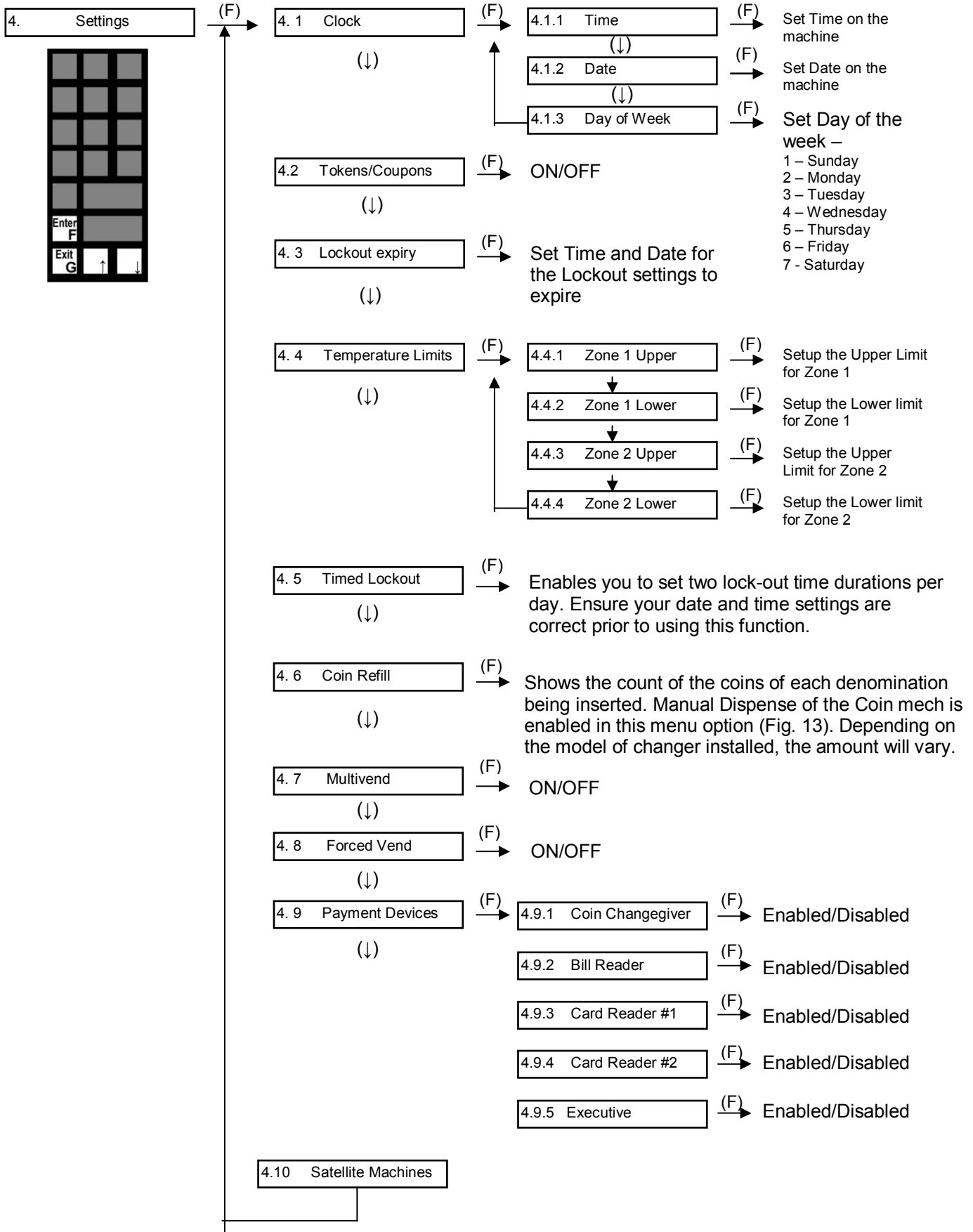
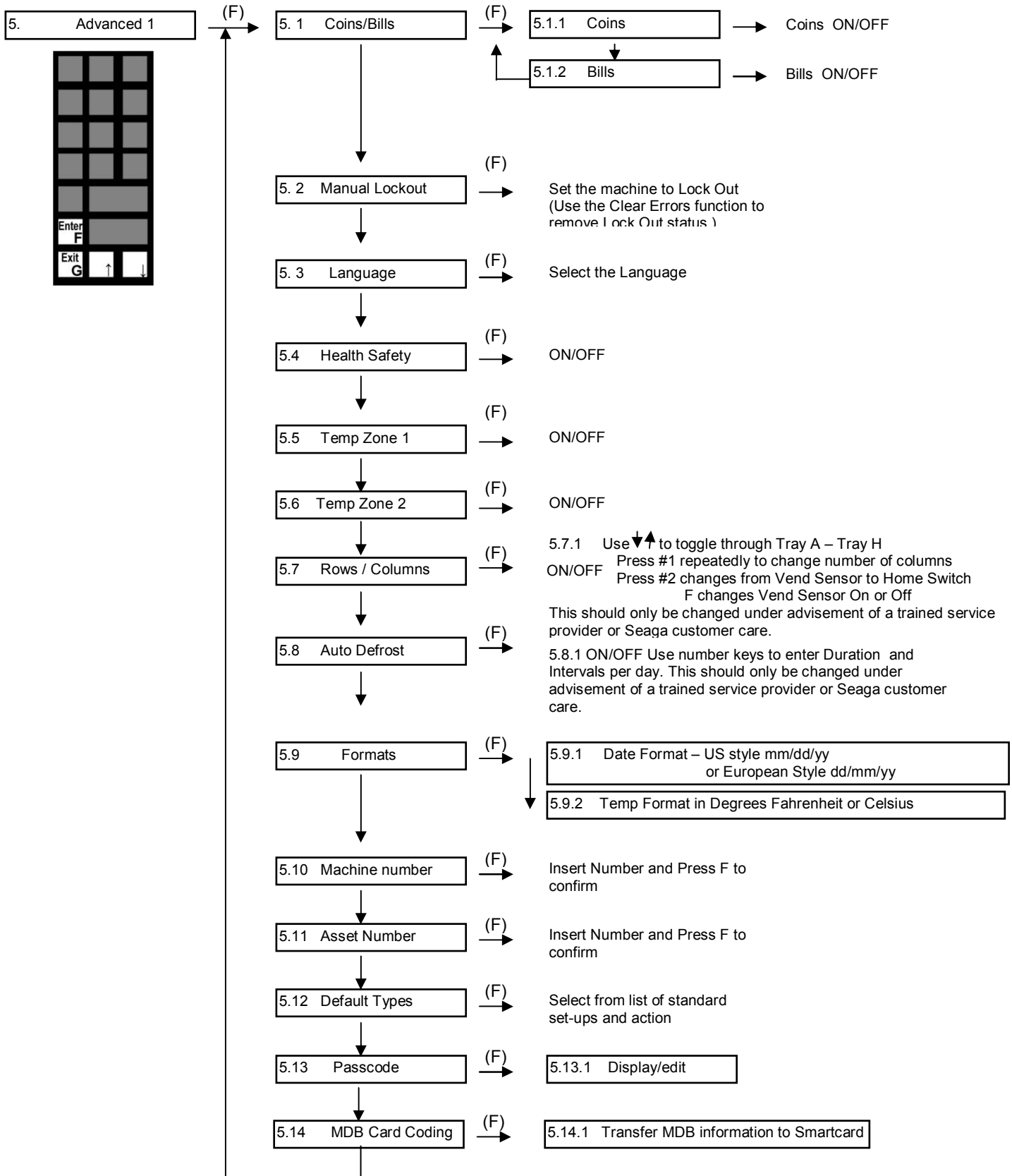


Fig. 13



ADVANCED SUB-MENU

ADVANCED - This menu is used to setup the Advanced Settings. Please enter the Pass Code in order to access this menu.



EXIT SERVICE MODE

To Exit the Service Mode or any of the menus, press "G".

SECTION 4

SMARTWARE V2.1.0

The Seaga Smartware setup utility enables Setup smart cards to be used to set the configuration of the new generation of Seaga vending machine controller boards. The utility works in conjunction with a USB smart card reader.

- **System Requirements**

- Seaga Smartware CD
- Approved USB Card Reader
- Seaga Smart Cards
- PC with the following specification:

| | Minimum | Recommended |
|----------------------|--------------------------|-------------------------------|
| Processor | Pentium 200MHz Processor | Pentium P4 1000MHz or better |
| RAM | 128M byte | > 256M byte RAM |
| Free Hard Disc Space | 20Mbyte | > 100Mbyte |
| Graphics | 800x600 16 colour SVGA | 1024 x 768 256 colour SVGA |
| Operating System | Windows 98SE | Windows Me, 2000, XP or Vista |
| CD-ROM | Yes | Yes |
| USB port | One | More than One |

- **Software Installation**

- (i) Installation of Card Reader Drivers

Either :

- Insert the CD into the CD ROM drive
- Select the "Install Card Reader Driver" option

Or (Windows XP / Vista only):

- Insert the CD into the CD ROM drive
- Plugg the card reader into the PC and follow the instructions in the "Add New Hardware" wizard. The Card Reader drivers are located in the **/drivers/** folder on the CD.

Or :

- Run the programme "**setup.exe**" in the "**/2/**" folder on the CD and follow the instructions.

- (ii) Installing the Smartware Application

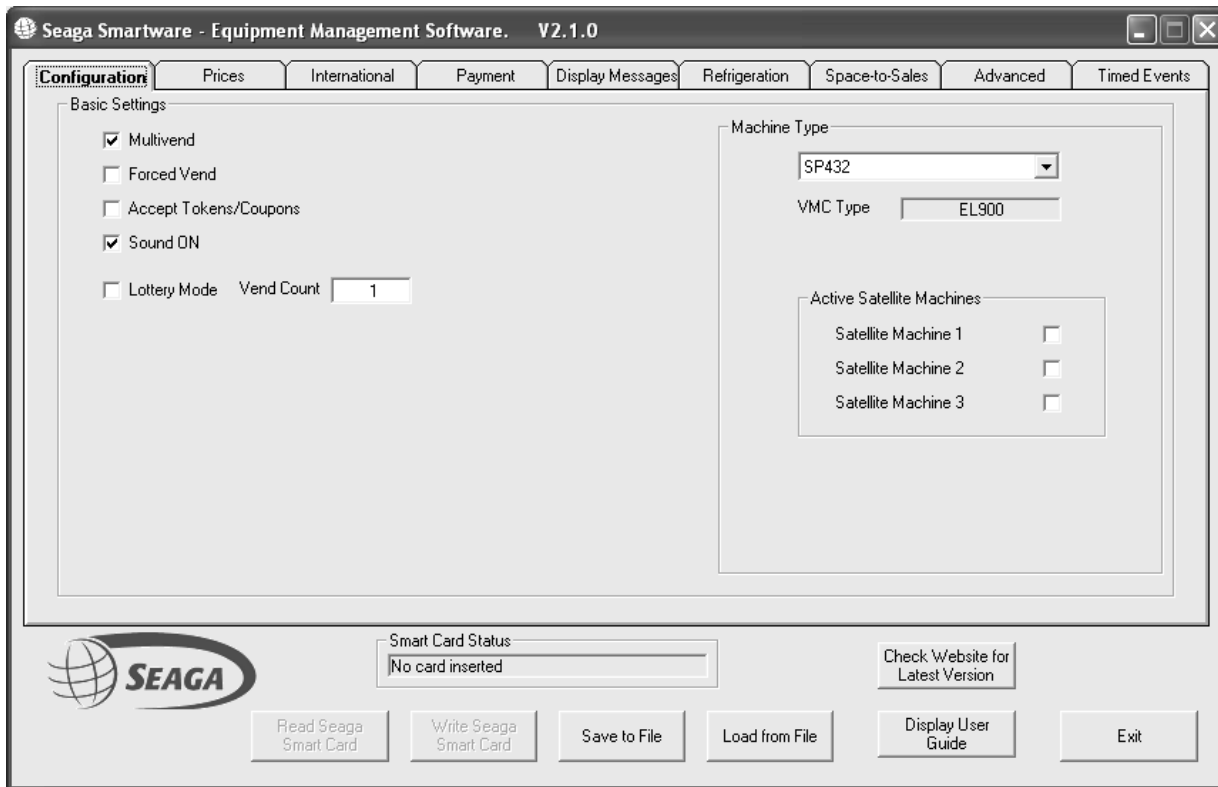
Either:

- Insert the CD into the CD ROM drive
- Select the "Install Seaga Smartware" option

Or:

- Run the program "**setup.exe**" in the top level folder on the CD and follow the instructions

CONFIGURATION PAGE



General Operations

Read Seaga Smart Card – read an existing smart card

Write Seaga Smart Card – programme a card with the current settings

Save to File – save the complete settings to a text file

Load from File – restore previously saved configurations

Check Website for Latest Version – Hyperlink to www.seagamfg.com/smartware/index.html

Display User Guide

– Hyperlink to [www.seagamfg.com/smartware/Seaga Smartware Guide.pdf](http://www.seagamfg.com/smartware/Seaga%20Smartware%20Guide.pdf)

Exit – close the utility programme

Card Status – shows the status of the card reader

| | |
|-----------------------|--|
| No card inserted | (Read and Write Card buttons disabled) |
| Seaga 256K smart card | Standard smart card inserted |
| Seaga 512K smart card | Alternate smart card inserted |

Notes

If an Audit or a Temperature Logging Card card type being read the data will be saved to a file once the read is complete. There is a prompt for the file name and an option to clear the card after it has been saved to the file. Refer to Appendix 1 for the file formats.

CONFIGURATION PAGE (continued)

Seaga Smartware - Equipment Management Software. V2.1.0

Configuration | Prices | International | Payment | Display Messages | Refrigeration | Space-to-Sales | Advanced | Timed Events

Basic Settings

- Multivend
- Forced Vend
- Accept Tokens/Coupons
- Sound ON
- Lottery Mode
- Vend Count:

Machine Type

Machine Type:

VMC Type:

Active Satellite Machines

- Satellite Machine 1
- Satellite Machine 2
- Satellite Machine 3

Smart Card Status:

Check Website for Latest Version

Read Seaga Smart Card | Write Seaga Smart Card | Save to File | Load from File | Display User Guide | Exit

Machine Selection / Basic Settings

Use the **Machine Type** “pull-down” to select a standard machine configuration, or select a specific VMC type.

Multivend, **Forced Vend**, **Accept Tokens/Coupons** and **Sound ON** – check the option to enable the corresponding feature.

Lottery Mode – check this option and enter a “**Vend Count**” value to allow a free selection, every “**Vend Count**” vends.

Satellite Machine n – check the box to allow the VMC to work with the corresponding Satellite machine.

When a Satellite machine type (VMC type EL906) is selected there is an option to configure the machine as **Satellite 1**, **Satellite 2** or **Satellite 3**.

Note : some features described in this guide are not available on all VMC configurations. If a particular item is “greyed out” or not shown, it is not available for the current machine.

PRICES PAGE

Seaga Smartware - Equipment Management Software. V2.1.0

Configuration Prices International Payment Display Messages Refrigeration Space-to-Sales Advanced Timed Events

Main Prices

| | | | | | | | | | | | | | | | |
|----|----|----|----|----|----|----|----|----|----|----|----|----|----|----|----|
| A2 | 75 | A4 | 75 | A6 | 75 | A8 | 75 | | | | | | | | |
| B2 | 75 | B4 | 75 | B6 | 75 | B8 | 75 | | | | | | | | |
| C2 | 75 | C4 | 75 | C6 | 75 | C8 | 75 | | | | | | | | |
| D1 | 75 | D2 | 75 | D3 | 75 | D4 | 75 | D5 | 75 | D6 | 75 | D7 | 75 | D8 | 75 |
| E1 | 75 | E2 | 75 | E3 | 75 | E4 | 75 | E5 | 75 | E6 | 75 | E7 | 75 | E8 | 75 |
| F2 | 75 | F4 | 75 | F6 | 75 | F8 | 75 | | | | | | | | |

Price Bank: Main Prices Machine: Main Machine

Set All Prices ALL Price: 100

Smart Card Status: No card inserted

Check Website for Latest Version

Read Seaga Smart Card Write Seaga Smart Card Save to File Load from File Display User Guide Exit

Depending on the machine configuration, up to 80 Price Boxes will be displayed for the machine.

To set a particular **price** type the value, in cents/pence, into the corresponding **price box**.

To set **ALL** the prices to the same amount, enter the amount in the **ALL Price** box and click the **Set All Prices** button.

The VMC can hold prices for the Main Machine and also up to three Satellite (MDB USD) machines – prices for the satellite machines can be accessed using the **Machine** “pull down” menu.

Individual selections may be named – refer to the **Text Messages** page for more details

PRICES PAGE (continued)

Seaga Smartware - Equipment Management Software. V2.1.0

Configuration Prices International Payment Display Messages Refrigeration Space-to-Sales Advanced Timed Events

Discount Prices

| | | | | | | | | | | | | | | | |
|----|----|----|----|----|----|----|----|----|----|----|----|----|----|----|----|
| A2 | 40 | A4 | 40 | A6 | 40 | A8 | 40 | | | | | | | | |
| B2 | 40 | B4 | 40 | B6 | 40 | B8 | 40 | | | | | | | | |
| C2 | 40 | C4 | 40 | C6 | 40 | C8 | 40 | | | | | | | | |
| D1 | 40 | D2 | 40 | D3 | 40 | D4 | 40 | D5 | 40 | D6 | 40 | D7 | 40 | D8 | 40 |
| E1 | 40 | E2 | 40 | E3 | 40 | E4 | 40 | E5 | 40 | E6 | 40 | E7 | 40 | E8 | 40 |
| F2 | 40 | F4 | 40 | F6 | 40 | F8 | 40 | | | | | | | | |

Price Bank: Discount Prices Machine: Main Machine Set All Prices ALL Price: 100

Smart Card Status: No card inserted Check Website for Latest Version

Read Seaga Smart Card Write Seaga Smart Card Save to File Load from File Display User Guide Exit

Discount Prices

Select **Discount Prices** using the **Price Bank** pull-down.

The VMC can operate at discounted prices between the **Discount Start Time** and **Discount End Time** points - refer to the "Timed Events" section.

PRICES PAGE (continued)

| | Price | Selection 1 | + Selection 2 | + Selection 3 | + Selection 4 |
|------|-------|-------------|---------------|---------------|---------------|
| GG1 | 200 | A4 | D8 | D7 | |
| GG2 | 200 | D1 | BA10 | | |
| GG3 | 0 | | | | |
| GG4 | 0 | | | | |
| GG5 | 0 | | | | |
| GG6 | 0 | | | | |
| GG7 | 0 | | | | |
| GG8 | 0 | | | | |
| GG9 | 0 | | | | |
| GG10 | 0 | | | | |

Price Bank: Meal Deals (dropdown)
Machine: Main Machine (dropdown)
Set All Prices: [button]
ALL Price: 100 (input field)
Smart Card Status: No card inserted (text field)
Check Website for Latest Version: [button]
Read Seaga Smart Card: [button]
Write Seaga Smart Card: [button]
Save to File: [button]
Load from File: [button]
Display User Guide: [button]
Exit: [button]

Meal Deals

These are multiple selections that may be offered at a discount price for the group of selections.

Meal deals are selected using the special selection prefix “GG” followed by the 1 – 10 key. The Meal Deal price is charged to the customer and multiple products are vended as specified.

Each of the 10 meal deals can have an individual price, followed by a list of selections that make up the deal. Each deal can comprise up to 4 selections which may be from the Main machine, or from Satellite machines. In the example above meal deal GG2 comprised selection D1 from the main machine plus selection A10 from the second satellite machine.

INTERNATIONAL PAGE

Seaga Smartware - Equipment Management Software. V2.1.0

Configuration Prices **International** Payment Display Messages Refrigeration Space-to-Sales Advanced Timed Events

International Settings

Language
English

Date Style
 dd/mm/yy
 mm/dd/yy

Clock
 24 Hour Style xx:xx
 12 Hour Style (AM/PM)

Currency Display
Symbol: \$ Decimal Places: 00.00
Custom Symbol: AB

Temperature Display
 C
 F

Automatic Daylight Savings Adjustment
USA

Smart Card Status: No card inserted

Check Website for Latest Version

Read Seaga Smart Card Write Seaga Smart Card Save to File Load from File Display User Guide Exit

Language

Select the default language for the display using the pull-down list. One language option is **EEPROM**. This language bank may be edited for special configurations and non-supported languages. Refer to the **Text Messages** page for more details.

Currency Display

Choose the desired currency **Symbol** and the number of **Decimal Places** to be displayed. If the required currency symbol is not in the options, choose **Custom** and type in two characters in the **Custom Symbol** box.

Date Style

Choose between **mm/dd/yy** and **dd/mm/yy** styles

Temperature

Choose between displaying Centigrade and Fahrenheit. **IMPORTANT**: Check the values on the **Refrigeration Page** AFTER changing the Temperature scale.

Clock

Choose between 24 hour and 12 hour modes to be displayed.

Select the **Daylight Saving Time** option for automatic summer/winter changes in the **USA** and the **UK/Europe** if required.

PAYMENT PAGE

Seaga Smartware - Equipment Management Software. V2.1.0

Configuration Prices International **Payment** Display Messages Refrigeration Space-to-Sales Advanced Timed Events

Coin Changegiver

| | Enabled | Enabled in Exact Change |
|---------|-------------------------------------|-------------------------------------|
| Coin 1 | <input checked="" type="checkbox"/> | <input checked="" type="checkbox"/> |
| Coin 2 | <input checked="" type="checkbox"/> | <input checked="" type="checkbox"/> |
| Coin 3 | <input checked="" type="checkbox"/> | <input checked="" type="checkbox"/> |
| Coin 4 | <input checked="" type="checkbox"/> | <input checked="" type="checkbox"/> |
| Coin 5 | <input checked="" type="checkbox"/> | <input checked="" type="checkbox"/> |
| Coin 6 | <input checked="" type="checkbox"/> | <input checked="" type="checkbox"/> |
| Coin 7 | <input checked="" type="checkbox"/> | <input checked="" type="checkbox"/> |
| Coin 8 | <input checked="" type="checkbox"/> | <input checked="" type="checkbox"/> |
| Coin 9 | <input checked="" type="checkbox"/> | <input checked="" type="checkbox"/> |
| Coin 10 | <input checked="" type="checkbox"/> | <input checked="" type="checkbox"/> |
| Coin 11 | <input checked="" type="checkbox"/> | <input checked="" type="checkbox"/> |
| Coin 12 | <input checked="" type="checkbox"/> | <input checked="" type="checkbox"/> |
| Coin 13 | <input checked="" type="checkbox"/> | <input checked="" type="checkbox"/> |
| Coin 14 | <input checked="" type="checkbox"/> | <input checked="" type="checkbox"/> |
| Coin 15 | <input checked="" type="checkbox"/> | <input checked="" type="checkbox"/> |
| Coin 16 | <input checked="" type="checkbox"/> | <input checked="" type="checkbox"/> |

Manual Dispense ON

Bill Reader

| | Enabled | Use Escrow | High Security |
|---------|-------------------------------------|-------------------------------------|-------------------------------------|
| Bill 1 | <input checked="" type="checkbox"/> | <input checked="" type="checkbox"/> | <input checked="" type="checkbox"/> |
| Bill 2 | <input checked="" type="checkbox"/> | <input checked="" type="checkbox"/> | <input checked="" type="checkbox"/> |
| Bill 3 | <input checked="" type="checkbox"/> | <input checked="" type="checkbox"/> | <input checked="" type="checkbox"/> |
| Bill 4 | <input checked="" type="checkbox"/> | <input checked="" type="checkbox"/> | <input checked="" type="checkbox"/> |
| Bill 5 | <input checked="" type="checkbox"/> | <input checked="" type="checkbox"/> | <input checked="" type="checkbox"/> |
| Bill 6 | <input checked="" type="checkbox"/> | <input checked="" type="checkbox"/> | <input checked="" type="checkbox"/> |
| Bill 7 | <input checked="" type="checkbox"/> | <input checked="" type="checkbox"/> | <input checked="" type="checkbox"/> |
| Bill 8 | <input checked="" type="checkbox"/> | <input checked="" type="checkbox"/> | <input checked="" type="checkbox"/> |
| Bill 9 | <input checked="" type="checkbox"/> | <input checked="" type="checkbox"/> | <input checked="" type="checkbox"/> |
| Bill 10 | <input checked="" type="checkbox"/> | <input checked="" type="checkbox"/> | <input checked="" type="checkbox"/> |
| Bill 11 | <input checked="" type="checkbox"/> | <input checked="" type="checkbox"/> | <input checked="" type="checkbox"/> |
| Bill 12 | <input checked="" type="checkbox"/> | <input checked="" type="checkbox"/> | <input checked="" type="checkbox"/> |
| Bill 13 | <input checked="" type="checkbox"/> | <input checked="" type="checkbox"/> | <input checked="" type="checkbox"/> |
| Bill 14 | <input checked="" type="checkbox"/> | <input checked="" type="checkbox"/> | <input checked="" type="checkbox"/> |
| Bill 15 | <input checked="" type="checkbox"/> | <input checked="" type="checkbox"/> | <input checked="" type="checkbox"/> |
| Bill 16 | <input checked="" type="checkbox"/> | <input checked="" type="checkbox"/> | <input checked="" type="checkbox"/> |

Payment Devices

MDB Coin Changegiver ON

MDB Bill Reader ON

MDB Card Reader #1 ON

Executive Changegiver

Exact Change Algorithm

Minimum Coins in Tube

Minimum Value in Tube (x max price)

Special Features

Card Reader can change Price

Smart Card Status: No card inserted

Check Website for Latest Version

Read Seaga Smart Card Write Seaga Smart Card Save to File Load from File Display User Guide Exit

Payment Devices

Check the corresponding boxes to turn Card, Coin and Bill payment on

Executive – check this box to operate with an Executive / Protocol-A coin changegiver.

Coin Changegiver

Check the **Enabled** box to allow the corresponding coin to be accepted normally, and the **Enabled in Exact Change** box to allow this coin to still be accepted when the machine is in Exact Change mode.

Check the **Manual Dispense ON** box to allow tubes to be emptied manually.

Bill Reader

Check the **Enabled** box to allow the corresponding Bill to be accepted. Check the **Use Escrow** box to hold the Bill for change and the **High Security** box to use the corresponding bill acceptance security level.

Exact Change Algorithm

The VMC applies two criteria for creating the **Exact Change** condition. **Exact Change** is set when ANY tube has less coins in the tube than the **Minimum Coins In Tube** quantity OR if the total value of the coins in the tubes is less than the highest price set multiplied by the **Minimum Value in Tube** multiplier.

Special Features

Card Reader can Change Price – check this box to allow the card reader device to apply discounts.

SPACE to SALES PAGE

Seaga Smartware - Equipment Management Software. V2.1.0

Configuration Prices International Payment Display Messages Refrigeration **Space-to-Sales** Advanced Timed Events

Space-to-Sales

| | Column 1 | Column 2 | Column 3 | Column 4 | Column 5 | Column 6 | Column 7 | Column 8 | Column 9 | Column 10 |
|--------|----------|----------|----------|----------|----------|----------|----------|----------|----------|-----------|
| Tray A | | A2 | | A4 | | A6 | | A8 | | |
| Tray B | | B2 | | B4 | | B6 | | B8 | | |
| Tray C | | C2 | | C4 | | C6 | | C8 | | |
| Tray D | D2 | D3 | D1 | D4 | D5 | D6 | D7 | D8 | | |
| Tray E | E1 | E2 | E3 | E4 | E5 | E6 | E7 | E8 | | |
| Tray F | | F2 | | F4 | | F6 | | F8 | | |
| Tray G | | | | | | | | | | |
| Tray H | | | | | | | | | | |

Hot Buttons
Active

Smart Card Status
No card inserted

Check Website for Latest Version

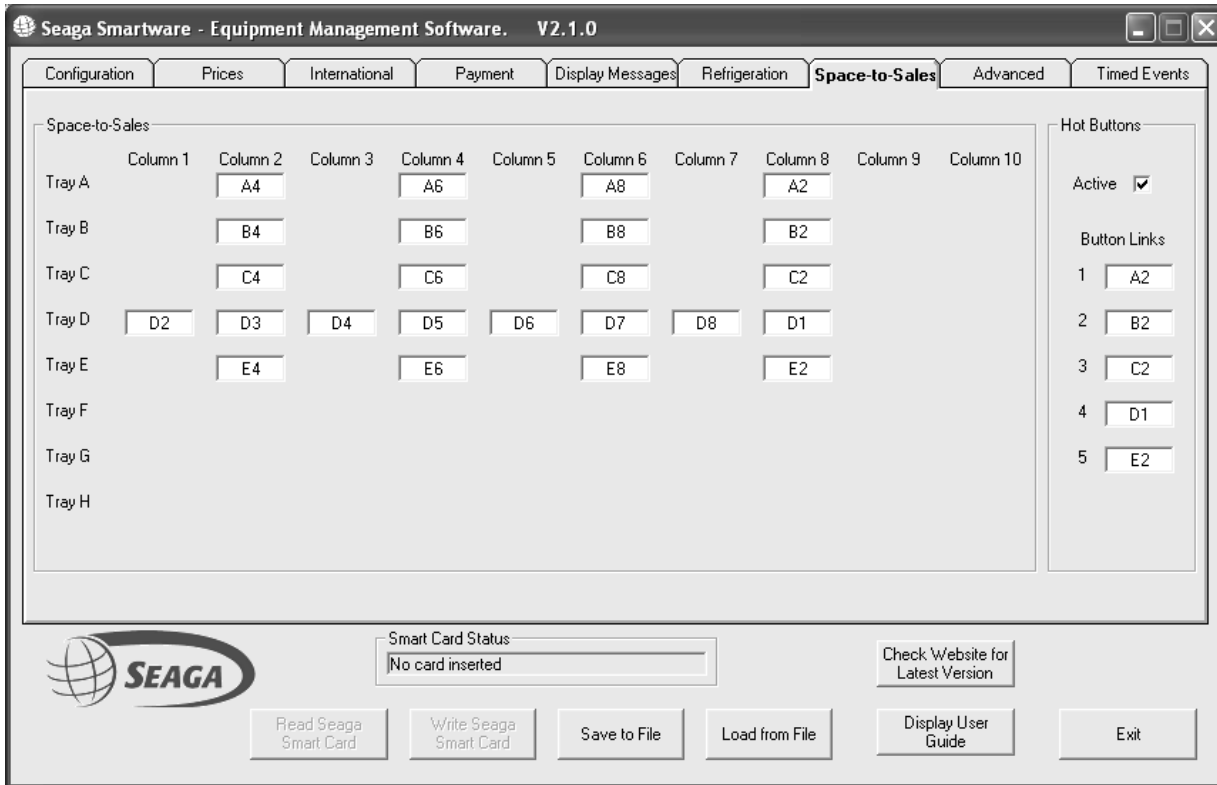
Read Seaga Smart Card Write Seaga Smart Card Save to File Load from File Display User Guide Exit

Stock Links

Where more than one selection contains the same product it is possible to link these selections together so that if one selection is sold out the product can be dispensed from another selection. This is particularly useful for increasing the effective stock for Meal Deals, and for Can/Bottles operation.

In the example above selections D1, D2 and D3 have the same type of product and have been linked together in a chain. All other selections are not linked and refer back to themselves.

HOT BUTTONS (Space to Sales Page)



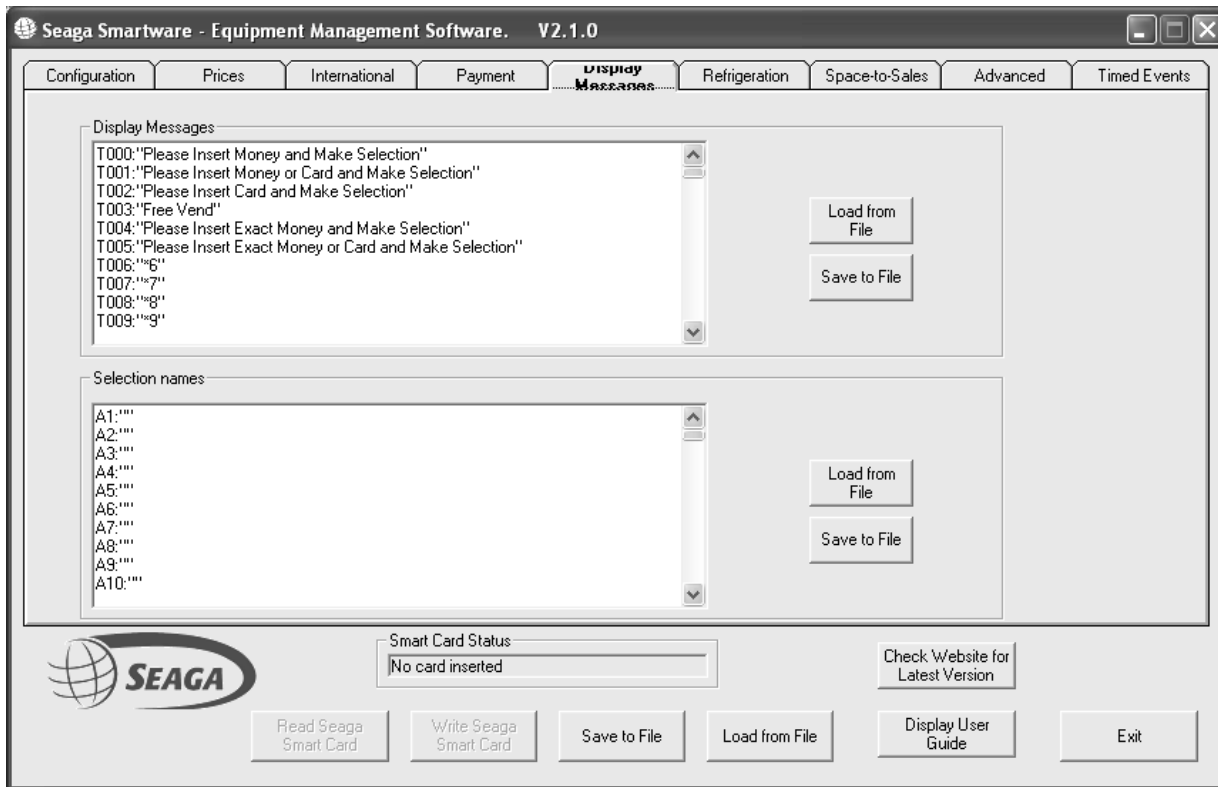
Hot Buttons

Check the “Active Button” to use Hot Buttons.

Hot Buttons replace the standard keypad selections with up to 5 direct, single button selections. For capacity the Space To sales links allow multiple internal spirals to stock the same product.

In the above example Hot Button 1 selects effectively Tray A. The hot button is linked to Selection A2 which in turn is linked in a chain to the other selections in Tray A. Similarly hot buttons 2 – 5 access trays B to E respectively.

TEXT MESSAGES PAGE



VMC Text Messages

This window displays the text held in EEPROM for an alternate language set. To Edit the **VMC Text Messages** use the **Save to File** button to save the text to a particular file . This file can be edited using **Notepad** and then reloaded using the **Load from File** button.

Selection Names

This window displays the text that is displayed for each **Selection** or **Meal Deal**. To Edit the **Selection Names** use the **Save to File** button to save the text to a particular file . This file can be edited using **Notepad** and then reloaded using the **Load from File** button.

When either of the "Save to File" options are selected Windows Notepad is launched directly to allow easy editing. **IMPORTANT:** When editing is complete save the changes from within Notepad and then use the **Load from File** button to install the changes.

ADVANCED PAGE

| Tray | Columns | Type | Timeout | Sold Out SW | Positive Vend Sensor |
|--------|---------|--------------|---------|--------------------------|-------------------------------------|
| Tray A | 4 | Cycle Switch | 5 | <input type="checkbox"/> | <input checked="" type="checkbox"/> |
| Tray B | 4 | Cycle Switch | 5 | <input type="checkbox"/> | <input checked="" type="checkbox"/> |
| Tray C | 4 | Cycle Switch | 5 | <input type="checkbox"/> | <input checked="" type="checkbox"/> |
| Tray D | 8 | Cycle Switch | 5 | <input type="checkbox"/> | <input checked="" type="checkbox"/> |
| Tray E | 4 | Cycle Switch | 5 | <input type="checkbox"/> | <input checked="" type="checkbox"/> |
| Tray F | N/A | | | | |
| Tray G | N/A | | | | |
| Tray H | N/A | | | | |

Build Configuration

This section allows the tray options to be defined for the particular machine. Select the number of **columns** for a particular tray, the Motor **Type** as below, the overall run **Timeout** in seconds for the motor and whether a **Sold Out switch** is fitted.

Motor Types :

- | | |
|--------------|--|
| Cycle Switch | - stops when the Home Switch is reached |
| PV Sensor | - stops when a product triggers the "Positive Vend Sensor" |
| Timed | - runs for a fixed period of time |

Positive Vend Sensor - check this box if one is fitted and to be used for the corresponding tray. (Please note that some older VMC software versions may not support individual use of the Positive Vend Sensor)

Timings

Selection Timeout is the number of seconds for which a selection is deemed made, and for which the **product name** and **price** are displayed.

Motor Nudge Time is the amount of time the motor is run after it has "homed" when **the Positive Vend Sensor** has not been triggered

Configuration

- | | |
|-----------------------------|---|
| Motor Nudges | - define the maximum number of nudges (up to 6) to be used |
| Diagnostics Passcode | - a 4 digit code for access to additional diagnostic features in the menus. |
| Advanced Passcode | - a 4 digit code for access to the Advanced menu features. |

Make Logging Smart Card / Make Audit Smart Card

- create a blank smart card of the selected type.

REFRIGERATION PAGE

Seaga Smartware - Equipment Management Software. V2.1.0

Configuration Prices International Payment Display Messages **Refrigeration** Space-to-Sales Advanced Timed Events

Refrigeration

| | | | | |
|---|------------------|---------|--------------------|--------|
| <input type="checkbox"/> Zone 1 ON | Low Limit | 32.0 F | High Limit | 32.0 F |
| <input checked="" type="checkbox"/> Zone 2 ON | Low Limit | 32.0 F | High Limit | 40 F |
| <input checked="" type="checkbox"/> Auto Defrost ON | Defrost Duration | 10 mins | First Defrost Time | 00:00 |
| <input type="checkbox"/> Health & Safety Mode ON | | | Interval (Hours) | 03 |

Smart Card Status: No card inserted

Check Website for Latest Version

Read Seaga Smart Card Write Seaga Smart Card Save to File Load from File Display User Guide Exit

Zone n ON – check the appropriate boxes turn refrigeration control ON for the Zone

Low Limit / High Limit Temperatures – set the upper and lower temperature limits for the zone. Note: the VMC internally works in 0.5C steps so exact Fahrenheit figures may be adjusted to the nearest 0.5C step.

Auto Defrost

Check the box to turn automatic defrosting ON. The defrost cycle is run for **Defrost Duration** minutes every **Interval** hours. The **First Defrost** after turning the feature ON may be set with the pull-down option. Thereafter the **Interval** value defines when the next defrost will occur.

Health & Safety Mode ON – check the box to turn this lockout mode ON.

TIMED EVENTS PAGE

The screenshot displays the 'Timed Events' configuration window in Seaga Smartware V2.1.0. The window title is 'Seaga Smartware - Equipment Management Software. V2.1.0'. The interface includes a menu bar with options: Configuration, Prices, International, Payment, Display Messages, Refrigeration, Space-to-Sales, Advanced, and Timed Events. The main area is a table with 32 rows, each representing an event. Each row has columns for 'Start', 'End', and days of the week (Su, Mo, Tu, We, Th, Fr, Sa). Below the days are checkboxes for actions: LO (Timed Lockout), En (Refrigeration Energy Saving Mode), Li (Lights OFF), FV (Free Vend), and DV (Discounted Vend). A 'Defaults' button is located at the bottom center of the table. Below the table, there is a 'Smart Card Status' section with a text box showing 'No card inserted' and buttons for 'Read Seaga Smart Card', 'Write Seaga Smart Card', 'Save to File', 'Load from File', 'Check Website for Latest Version', 'Display User Guide', and 'Exit'.

Version 1.10 and later Premier VMC software supports up to 32 separate timed events. Each event can be set to occur between the **START** and **END** times for the selected **days of the week**. Event times may overlap.

Each Event can then have the following actions (more than one selection may be applied)

- LO** Timed Lockout
- En** Refrigeration Energy Saving Mode
- Li** Lights OFF
- FV** Free Vend
- DV** Discounted Vend (If both **DV** and **FV** are selected, free vend will apply)

Use the **Defaults** button to clear the events back to the factory default configuration

Events 1 – 4 are backwards compatible with earlier versions of VMC software.

- Events 1 and 2** Timed Lockouts with shared **Days of the Week** active.
- Event 3** Energy Saving only
- Event 4** Discounted Vend only

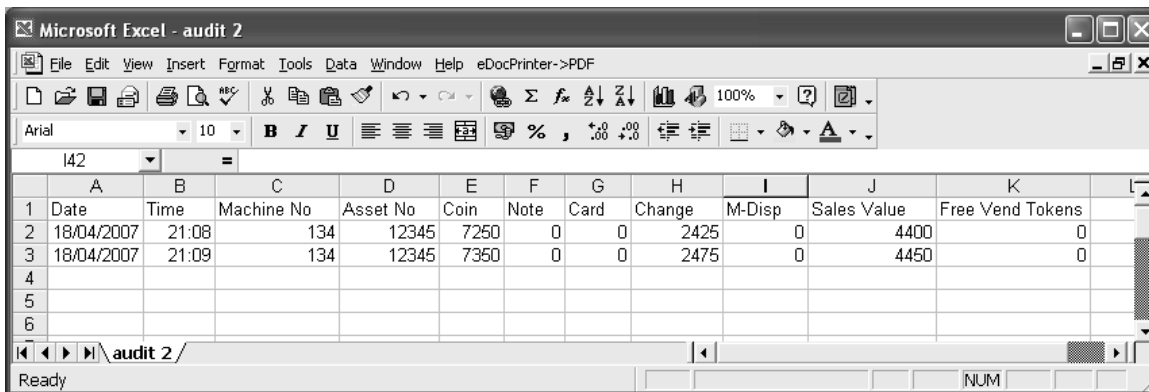
In the screenshot above the following events are set for an example “factory/office” application:

- Discounted prices for anyone working late 17:00 to 20:00 on weekdays
- Free vend for anyone working after 20:00 on weekdays and between 08:00 and 18:00 at weekends.
- Energy saving every night from 22:00 until 06:00 the next morning, which means that In Energy saving Mode, the compressor will shut off at 40 °F and turn on when the temperature reaches 43° F. (During normal operation the temperature range is held from 37 °F to 43 °F.
- Timed Lockout between 10:00 and 10:15 on Tuesdays, Wednesdays and Thursdays for a “staff meeting”

Appendix 1 – File formats

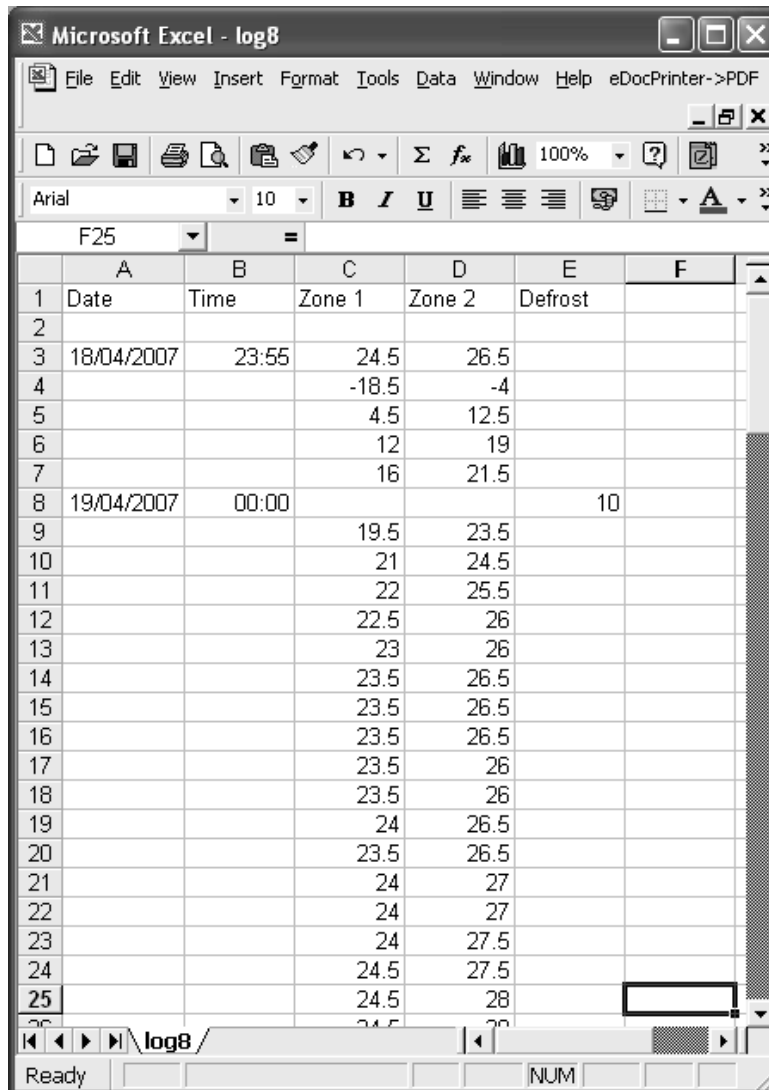
Both Audit and Temperature Logging Cards are saved to .csv (comma separated value) format files that can be imported into a number of packages, including Microsoft Excel. Records are tabulated with a title to each column.

Example Audit File – values are in base units (cents, pence etc.)



| | A | B | C | D | E | F | G | H | I | J | K |
|---|------------|-------|------------|----------|------|------|------|--------|--------|-------------|------------------|
| 1 | Date | Time | Machine No | Asset No | Coin | Note | Card | Change | M-Disp | Sales Value | Free Vend Tokens |
| 2 | 18/04/2007 | 21:08 | 134 | 12345 | 7250 | 0 | 0 | 2425 | 0 | 4400 | 0 |
| 3 | 18/04/2007 | 21:09 | 134 | 12345 | 7350 | 0 | 0 | 2475 | 0 | 4450 | 0 |
| 4 | | | | | | | | | | | |
| 5 | | | | | | | | | | | |
| 6 | | | | | | | | | | | |

Example Temperature Logging File – in this example, temperatures are in Centigrade, defrost duration is in minutes. Readings are logged approximately every minute.



| | A | B | C | D | E | F |
|----|------------|-------|--------|--------|---------|---|
| 1 | Date | Time | Zone 1 | Zone 2 | Defrost | |
| 2 | | | | | | |
| 3 | 18/04/2007 | 23:55 | 24.5 | 26.5 | | |
| 4 | | | -18.5 | -4 | | |
| 5 | | | 4.5 | 12.5 | | |
| 6 | | | 12 | 19 | | |
| 7 | | | 16 | 21.5 | | |
| 8 | 19/04/2007 | 00:00 | | | 10 | |
| 9 | | | 19.5 | 23.5 | | |
| 10 | | | 21 | 24.5 | | |
| 11 | | | 22 | 25.5 | | |
| 12 | | | 22.5 | 26 | | |
| 13 | | | 23 | 26 | | |
| 14 | | | 23.5 | 26.5 | | |
| 15 | | | 23.5 | 26.5 | | |
| 16 | | | 23.5 | 26.5 | | |
| 17 | | | 23.5 | 26 | | |
| 18 | | | 23.5 | 26 | | |
| 19 | | | 24 | 26.5 | | |
| 20 | | | 23.5 | 26.5 | | |
| 21 | | | 24 | 27 | | |
| 22 | | | 24 | 27 | | |
| 23 | | | 24 | 27.5 | | |
| 24 | | | 24.5 | 27.5 | | |
| 25 | | | 24.5 | 28 | | |

DELIVERY SYSTEM

Your vendor consists of the Keypad, 2 Line VF Display, Driver Motors, Product Trays, Helix Coils and Delivery Bin. The customer inserts money and enters their selection on the Keypad. The selection's Driver Motor turns the Helix Coil that vends the product into the Delivery Bin.

PRODUCT TRAYS

The SP Series features lock and release product trays. On the right side of each product tray you will find a Locking Lever (Fig. 14). To pull out the Product Tray push down on the Locking Lever and roll toward you to tilt position. Or completely push the locking lever to the back.

Fig. 14

**VIGILANT VEND SENSOR SYSTEM**

The Vigilant system is a series of infrared sensors that send a beam of light across the delivery bin. If this beam is broken by a product, the Premium machine knows that an item was delivered to the customer. If this beam is not broken, the Premium machine assumes that nothing was vended and turns the selection spirals by $\frac{1}{4}$ turns until a product delivery is sensed. If, after the coils have turned a full revolution back to home without delivering a product, the customer will be asked to make another selection or to press the Coin Return button to receive their money back.

Certain products can be problematic for any vend sensing system. Products that are very thin or very small in size may, on occasion, miss the beams. With proper loading of the machine, sensing systems are irrelevant. A comfort level is provided to customers who walk up to the machine and know, through technology, they will not experience a "rip-off". For this reason, a vend sensor system is desirable – however, if you vend very small or very thin items, you may want to consider turning off your sensing system in case of malfunction via product size. See the Service Mode section of this manual, Diagnostics sub-menu, for instructions.

The Vigilant sensors are located inside the delivery bin as shown in Figure 14 below. There is a red indicator light located on the left side when viewing the bin from the inside with the door open. This light should be lit when the system is on, indicating that there is power to the system. Blocking any of the beams turns off the red indicator light, which means the system is working correctly.

Note: When performing Test Motors without product loaded, it is a good idea to shut off the Vigilant system.

SECTION 6**TROUBLE SHOOTING**

1.

NO DISPLAY ON THE FRONT PANEL

- a. Transformer fuse blown
- b. Display board defective
- c. System control board defective
- d. Faulty display harness
- e. Harness may be unplugged
- f. Restart machine

2.

SELECTION WILL NOT VEND

- a. Vend mechanism binding on tray
- b. Product jammed
- c. Tray or Motor connection unplugged or faulty connection
- d. Bad motor or defective motor
- e. System control board defective
- f. Detection system may be blocked, if enabled

3.

MULTIPLE VENDS FROM ONE SELECTION

- a. System control board defective
- b. Defective motor switch
- c. Detection system malfunction, if enabled

4.

MULTIPLE VENDS MORE THAN ONE SELECTION SIMULTANEOUSLY

- a. Defective motor
- b. Motor harness not plugged into the vend motor correctly
- c. Defective or damaged motor interface board [KS11]
- d. Tray cable faulty
- e. System control board defective

5.

UNIT WILL NOT ACCEPT MONEY

- a. All Prices are set to zero or machine is set to Free Vend
- b. Will not accept bill if coins in coin changer below the minimum level
- c. Will not accept more than one bill if the bill equal or exceeds the highest priced item.
- d. No power to system control board
- e. Coin Mechanism or Bill acceptor defective.

A: These buttons are disabled in the normal operating mode to protect from unauthorized use. To enable the buttons enter the service mode, scroll to the settings submenu, press F to enter then scroll to Coin Refill and press F. The button will now be enabled. To exit press the G button multiple times.

Q: I rearranged my trays and now some selections don't work. Display says Make Alternate Selection.

A: Enter the service mode. Press the 10 button 4 times. Display should show Passcode Accepted. Scroll to Advanced sub menu and press F to enter. Scroll to Rows / columns setting and press F to enter. Display will show setting for each tray position. The 1 button will cycle through the different tray configurations. It will cycle from 0 (tray off) then to 4, 5, 7, 8, 10 then back to 0. Set this to the number of selections on that tray. When finished with the settings for that tray use the arrow keys to scroll to the next one to set. If you are finished press the G key multiple times to exit. This only applies to machines with software revision .65 and higher. Earlier versions will require a software update. Contact your distributor or sales person for update information.

Q: My machine will not take in bills but accepts change ok.

A: Several options here but the most common especially when first setting up the machine is that there is not enough change in the changer. By looking at the display it will give you a clue as to what may be wrong. If the display reads "Please Insert Exact Money...." that indicates there is not enough change in the changer. Fill the coin tubes

completely full. Completely full means you can't get any more change into the coin tube. Press the coin return button and the display should show Canceling. The display should now show "Please Insert Money....." without the word Exact.

Q: My machine still will not accept bills and the display does not indicate Exact change.

A: If the validator takes in the bill a ways but spits it back out, that indicates that the bill may be unacceptable or the validator needs cleaning. Follow the validator manufacturer's recommendation for cleaning.

Q: My machine will accept \$1 bills ok but not \$5 bills.

A: This situation can depend on several factors. The amount of change being reported in the changer and the highest vending price in the machine. Make sure the changer is full of change. If you are vending high dollar items you may need to replace the changer with a larger capacity model and/or one that utilizes dollar coins if the changer is constantly low on change.

Q: My machine will not accept the new \$5 bills.

A: Contact the bill validator manufacturer for upgrade instructions. Not accepting currency that has been changed due to a Federal Government mandate is not covered under our manufacturer's warranty.

Q: My machine will vend a product, display Vend Error then give my money back or allow me take make an alternate selection.

A: This indicates there is a problem detected with the vend motor. Each vend motor has a small micro switch inside that indicates when the motor has made one full revolution and returns back to what is referred to as the "home position". If this signal is not received back to the controller in a specified amount of time the controller will indicate an error and refund the money. The problem could be in an individual motor itself, the tray wire harness or any connection in between the tray to the control board. If the whole tray acts this way that usually indicates that the tray harness or any connection in between to the controller may be bad. The easiest way to troubleshoot this situation would be to swap tray connections where the tray harness plug plugs into the machine. For example if the problem appears on the A tray, unplug the A tray and the B tray (assuming they both have the same number of selections), swap the connections and plug the A tray into the B tray receptacle and vice versa. Now do your test vending by selecting the B selections on the keypad and the A tray should operate. If the problem follows the tray then suspect either the motor or the tray cable harness. If the problem stays with the A receptacle and now the B tray exhibits the problem then the problem is in a connection somewhere between the A receptacle and the controller board. Make sure to examine any and all connections for any loose wires, etc.

Q: My display is dead or intermittent but the rest of the machine appears to be working.

A: Check the gray flat ribbon cable connection between the display and the controller board to insure the plugs are plugged in securely.

Q: My machine will not cool.

A: Several things to check here.

1. Make sure the machine programming is set up properly so that Zone 2 is enabled and the proper temperature limits are set for Zone 2. Zone 2 lower should be set around 37 degrees and Zone 2 upper should be around 5-6 degrees warmer. If the temperature is set too cold then you risk the chance of evaporator freeze over.
2. On models equipped with a refrigeration fuse make sure it is not blown. The fuse needs to be a 20 amp Slo-Blo fuse. Nothing less. An easy way to test the fuse is to press on the lower door switch to see if the 3 evaporator fans run that are located below the bottom tray.
3. Inspect the evaporator coil to see if it may be frozen over. Using a flashlight shine it into the 3 evaporator fans located under the bottom tray. You are looking for aluminum fins behind the fan motors. If they are completely white or solid with ice this will keep the air from flowing properly and cause the machine to not cool. To thaw out remove the 3 prong condensing unit plug, not the evaporator fan plug and just close the door and let set for overnight to insure it completely defrosts. Be prepared in case the defrost water pan overflows on the floor. You may need to set some towels around and under the machine to catch any overflow. After the machine is thawed completely out you will want to check the temperature settings to insure they are not set too cold. You may also enter the Advanced menu and check the defrost settings. The standard defrost settings are for a duration (DUR) of 25 minutes and interval (INT) of 3 hours. This can be changed if need be. Press the lower door switch to insure all 3 evaporator fans run. Also close the door and listen to hear if the fans start when

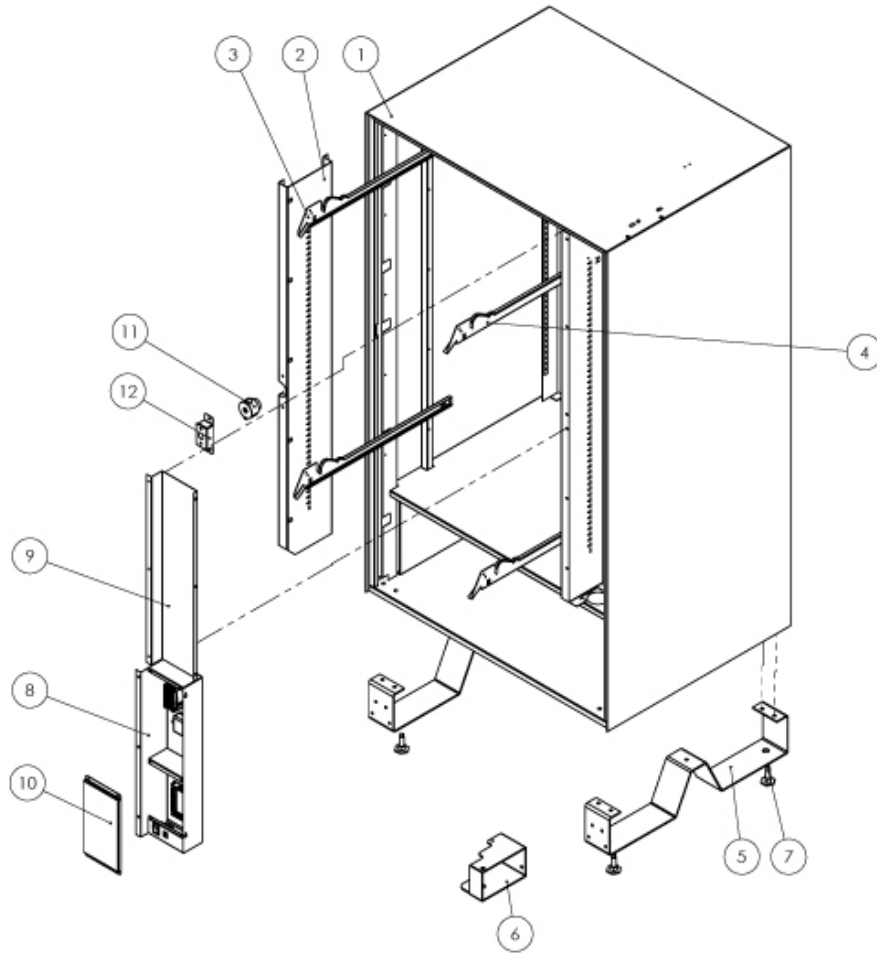
you close the door. If they don't this will also cause a freeze over. You may need to adjust the door switch to facilitate proper operation.

4. Check the upper door switch. The easiest test is to close the door then while opening the door watch the display to see if you see the message Sales Value \$xxxx.xx in the display. If you do not then suspect the upper door switch may need adjustment. You can reach over the door and press it manually while watching the display to see if it works.
5. As a manual test of the cooling system you can enter the Diagnostics section of the menu and select the Relays test function. Select Relay 02, press F and the cooling system should turn on momentarily.
6. Another manual test you can try on models equipped with a standard 3 prong receptacle for the cooling assembly is unplug the cooling assembly plug from the refrigeration control panel and plug that cord into a standard 3 prong extension cord. The cooling system should run.

CAUTIONS:

1. High voltage is located in the area of the unit and could cause injury or death.
2. Replacement of the bill acceptor, coin changer, front panel display, system control board or vend motors should only be performed by trained personnel.

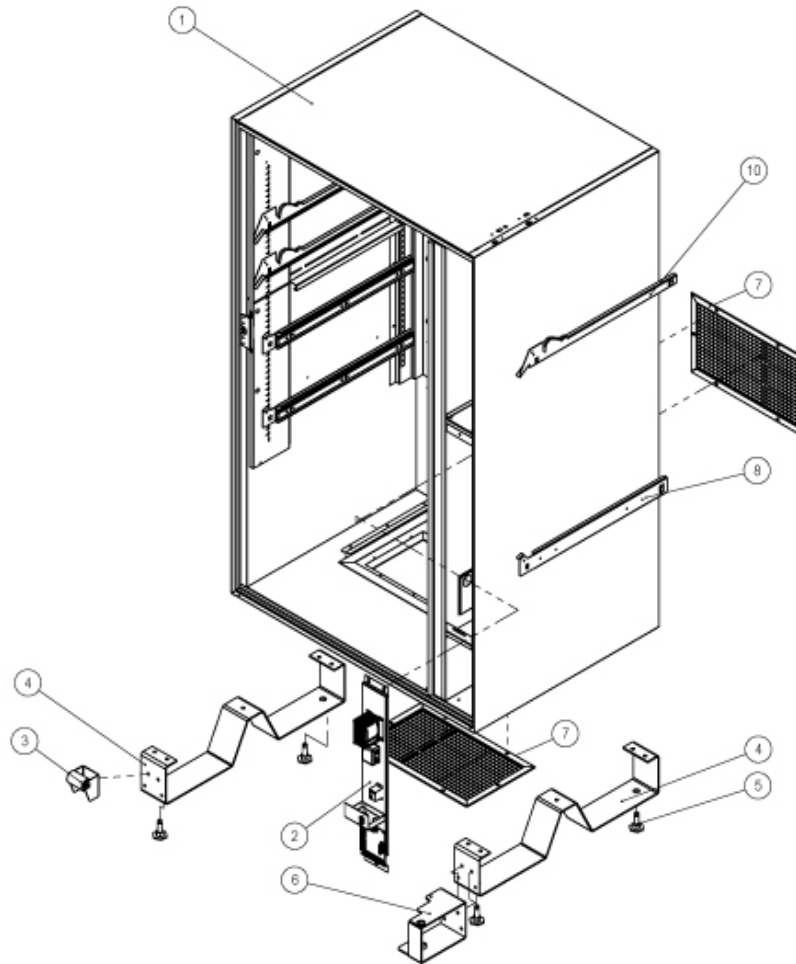
Ambient Cabinet Assembly



Parts List

| ITEM | PART NO. | DESCRIPTION |
|------|-----------|-----------------------------|
| 1 | SAI88002A | CABINET (5-WIDE AMBIENT) |
| 1 | SAI70006A | CABINET (4-WIDE AMBIENT) |
| 2 | STI70035 | BRACKET, LEFT FRONT, 5-WIDE |
| 2 | STI70035B | BRACKET, LEFT FRONT, 4-WIDE |
| 3 | STI900 | RAIL, TRAY, LEFT |
| 4 | STI901 | RAIL, TRAY, RIGHT |
| 5 | STI573A | LEGS |
| 6 | SAI778 | SUPPORT, DOOR |
| 7 | HAI705 | LEVELER, LEG |
| 8 | SAI88004 | ASSEMBLY, ELECTRICAL BOX |
| 9 | STI70039 | PANEL, WIRING DIAGRAM |
| 10 | STI70034 | COVER, TRANSFORMER |
| 11 | HAI910 | SPLIT NUT, T-HANDLE LOCK |
| 12 | STI87038 | BRACKET, SPLIT NUT MOUNTING |

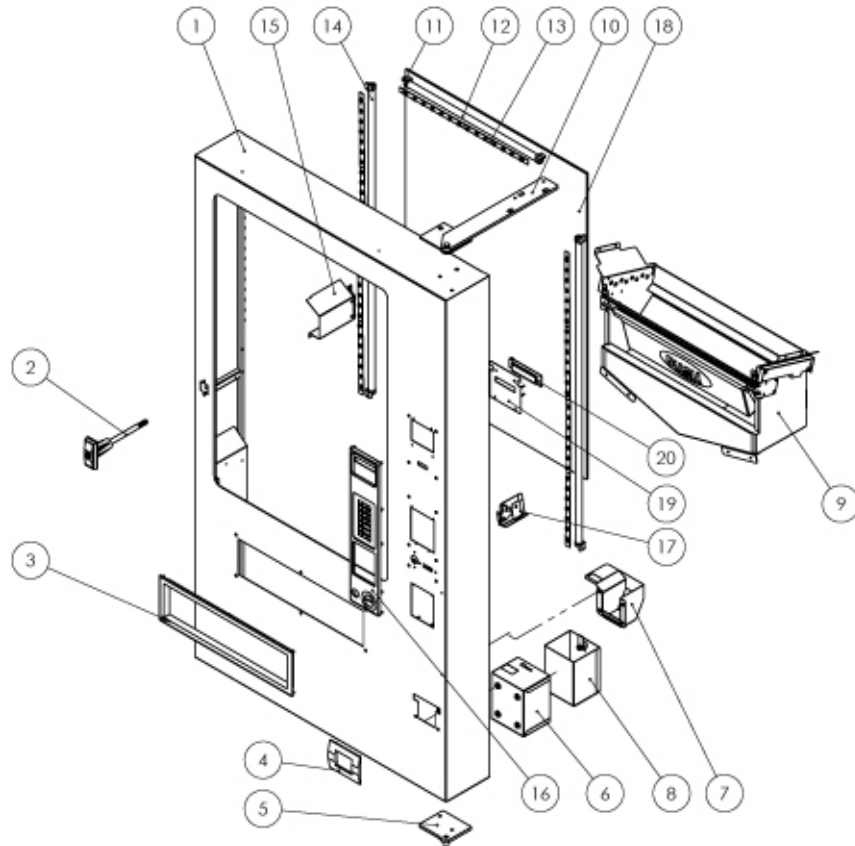
Refrigerated Cabinet Assembly



Parts List

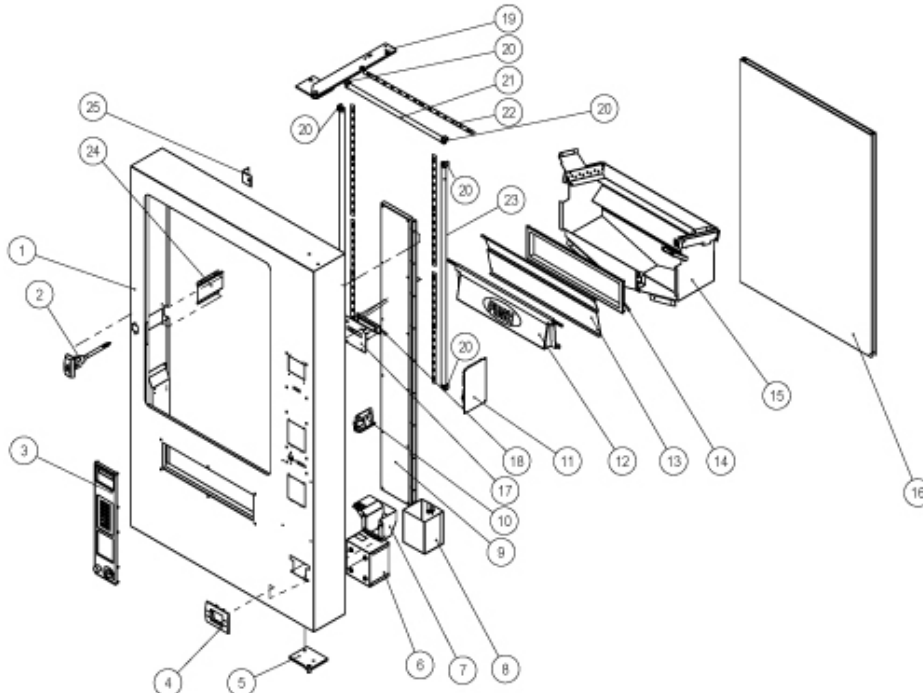
| ITEM | PART NO. | DESCRIPTION |
|------|----------|--|
| 1 | SAI87001 | CABINET, INSULATED (5-WIDE REFRIGERATED) |
| 1 | SAI84007 | CABINET, INSULATED (4-WIDE REFRIGERATED) |
| 2 | SAI793 | ASSEMBLY, ELECTRICAL PANEL |
| 3 | SAI764A | ASSEMBLY, DOOR SUPPORT ROLLER |
| 4 | STI573A | LEGS |
| 5 | HAI705 | LEVELER, LEG |
| 6 | SAI781A | SUPPORT, DOOR |
| 7 | STI58022 | GRILL |
| 8 | STI579 | RAIL, BEVERAGE TRAY, LEFT/RIGHT |
| 9 | STI900 | RAIL, SNACK TRAY, LEFT |
| 10 | STI901 | RAIL, SNACK TRAY, RIGHT |

Ambient Door Assembly



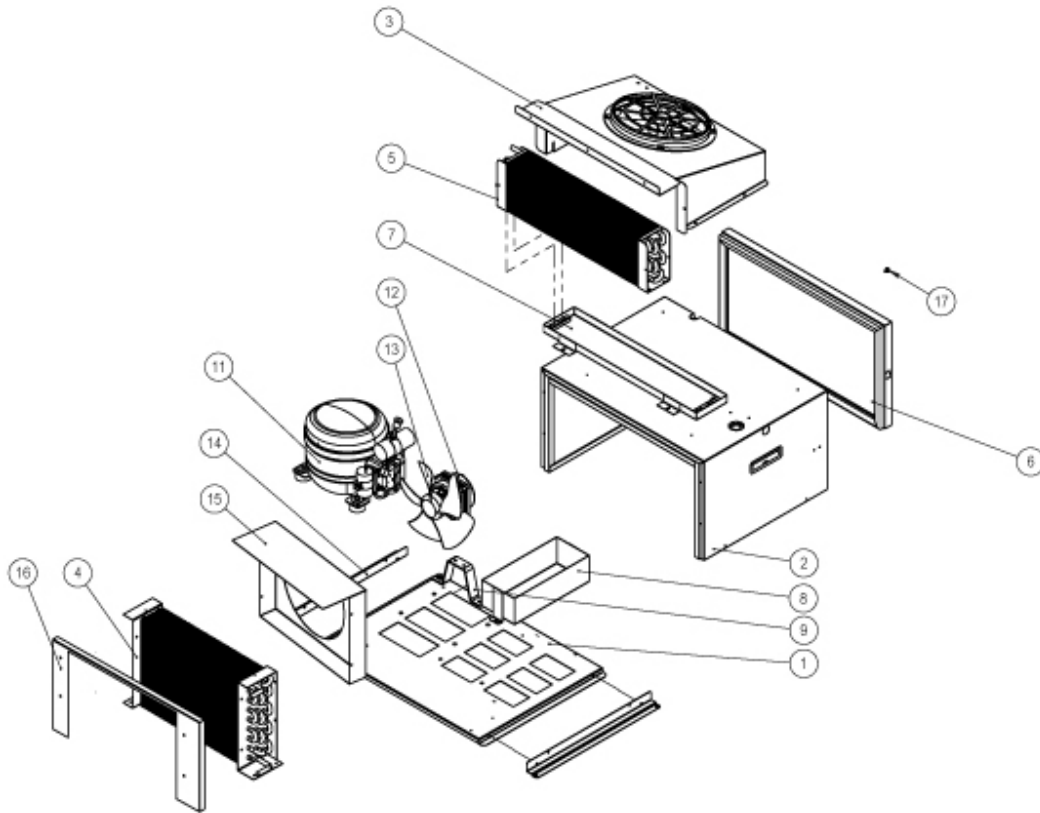
| ITEM | PART NO. | DESCRIPTION |
|------|-----------|---|
| 1 | SAI88012B | ASSEMBLY, DOOR (5-WIDE AMBIENT) |
| 1 | SAI70003A | ASSEMBLY, DOOR (4-WIDE AMBIENT) |
| 2 | HAI909 | T-HANDLE |
| 3 | PLI940 | FRAME, DELIVERY DOOR |
| 4 | PLI939 | BEZEL, COIN RETURN |
| 5 | SAI780 | ASSEMBLY, HINGE, BOTTOM |
| 6 | SAI87033 | ASSEMBLY, GUIDE COIN BOX |
| 7 | SA87038 | TRAY, COIN RETURN |
| 8 | SAI87035 | ASSEMBLY, COIN BOX |
| 9 | SAI809 | ASSEMBLY, DELIVERY BIN (5-WIDE AMBIENT) |
| 9 | SAI810 | ASSEMBLY, DELIVERY BIN (4-WIDE AMBIENT) |
| 10 | SAI777 | ASSEMBLY, HINGE, TOP |
| 11 | PLI2082 | CAP, TUBE, LED |
| 12 | HAI990A | TUBE, LED |
| 13 | ELI962 | LED |
| 14 | HAI990 | TUBE, LED |
| 15 | STI87025A | COVER, DOOR LOCK |
| 16 | PLI936 | BEZEL, KEYPAD |
| 17 | SAI773A | ASSEMBLY, COIN RELEASE |
| 18 | GLI953A | GLASS (5-WIDE AMBIENT) |
| 18 | GLI962 | GLASS (4-WIDE AMBIENT) |
| 19 | STI70062 | PLATE, DISPLAY MOUNTING |
| 20 | ELI909 | DISPLAY |

Refrigerated Door Assembly



| ITEM | PART NO. | DESCRIPTION |
|------|-----------|--|
| 1 | SAI87009 | ASSEMBLY, DOOR, INSULATED (5-WIDE) |
| 1 | SAI84009 | ASSEMBLY, DOOR, INSULATED (4-WIDE) |
| 2 | HAI909 | T-HANDLE |
| 3 | PLI936 | BEZEL, KEYPAD |
| 4 | PLI939 | BEZEL, COIN RETURN |
| 5 | SAI780 | ASSEMBLY, HINGE, BOTTOM |
| 6 | SAI87033 | BRACKET, COIN BOX |
| 7 | SAI87038 | TRAY, COIN RETURN |
| 8 | SAI87035 | ASSEMBLY, COIN BOX |
| 9 | SAI87031 | ASSEMBLY, ELECTRICAL DOOR, REFRIGERATED |
| 10 | SAI773A | ASSEMBLY, COIN RELEASE |
| 11 | ELI900 | VMC |
| 12 | PLI943A | DELIVERY DOOR (5-WIDE) |
| 12 | PLI943 | DELIVERY DOOR (4-WIDE) |
| 13 | STI87049 | PANEL, ANTI-THEFT (5-WIDE) |
| 13 | STI58036 | PANEL, ANTI-THEFT, BIN (4-WIDE) |
| 14 | PLI940 | DELIVERY DOOR |
| 15 | SAI785 | ASSEMBLY, DELIVERY BIN (5-WIDE REFRIGERATED) |
| 15 | SAI360 | ASSEMBLY, DELIVERY BIN (4-WIDE REFRIGERATED) |
| 16 | GLI954A | GLASS, INSULATED (5-WIDE) |
| 16 | GLI952A | GLASS, INSULATED (4-WIDE) |
| 17 | STI70061 | PLATE, DISPLAY MOUNTING |
| 18 | ELI909 | DISPLAY |
| 19 | SAI777 | ASSEMBLY, HINGE, TOP |
| 20 | PLI2082 | CAP, TUBE, LED |
| 21 | HAI990A | TUBE, LED |
| 22 | ELI962 | LED |
| 23 | HAI990 | TUBE, LED |
| 24 | STI87025A | COVER, DOOR LOCK 5-WIDE |
| 24 | STI87025B | COVER, DOOR LOCK 4-WIDE |
| 25 | STI70033 | BRACKET, DEX SUPPORT |

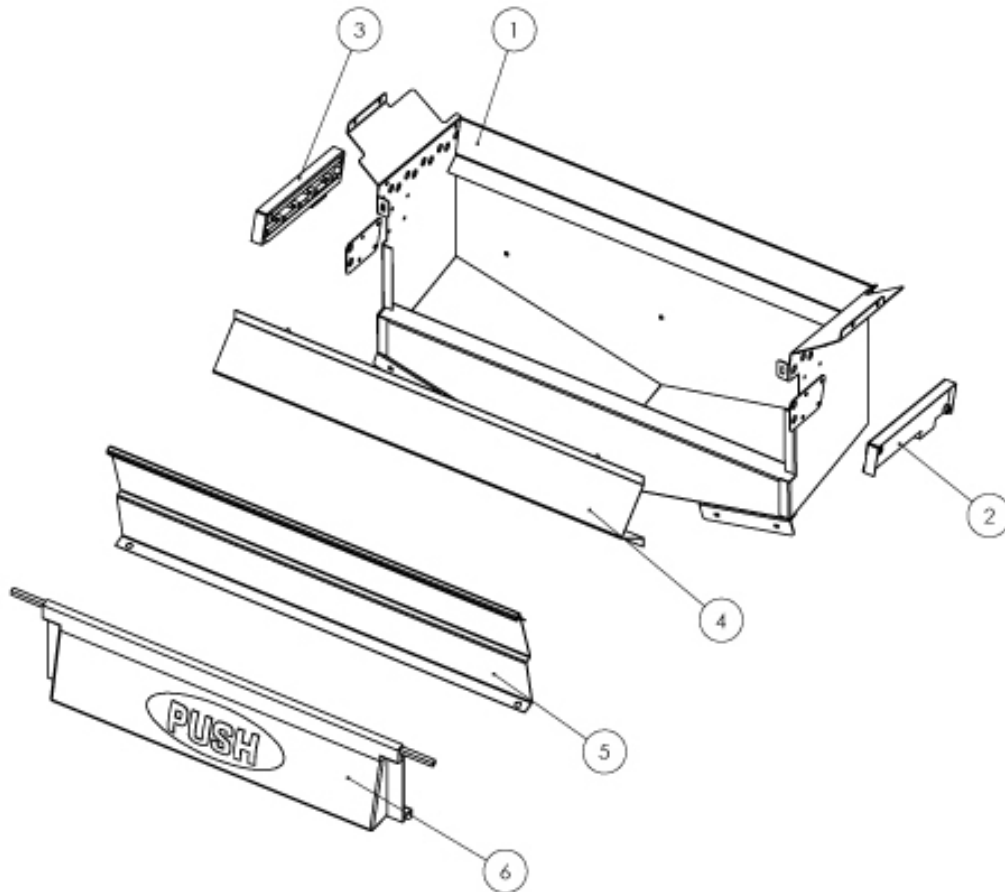
Refrigeration Deck Assembly



Parts List

| ITEM | PART NO. | DESCRIPTION |
|------|-----------|------------------------------|
| 1 | STI87029 | TRAY, REFRIGERATION DECK |
| 2 | SAI87011 | DECK HOUSING |
| 3 | SAI87051 | ASSEMBLY, EVAPORATOR HOUSING |
| 4 | REI819 | CONDENSER |
| 5 | REI830 | EVAPORATOR |
| 6 | SAI87013 | DOOR REFRIGERATION DECK |
| 7 | SAI87013 | TRAY EVAPORATOR |
| 8 | STI87030 | TRAY, CONDENSATE |
| 9 | STI578 | BRACKET, CONDENSER MOTOR |
| 10 | STI87019 | BRACKET, LATCH CLAMP |
| 11 | REI872 | COMPRESSOR |
| 12 | REI612 | MOTOR, CONDENSOR |
| 13 | REI861 | BLADE, CONDENSOR |
| 14 | STI8703T6 | L-ANGLE, REF. DECK HOUSING |
| 15 | STI87037 | SHROUD, CONDENSER |
| 16 | STI87038 | BRACKET, CONDENSER |

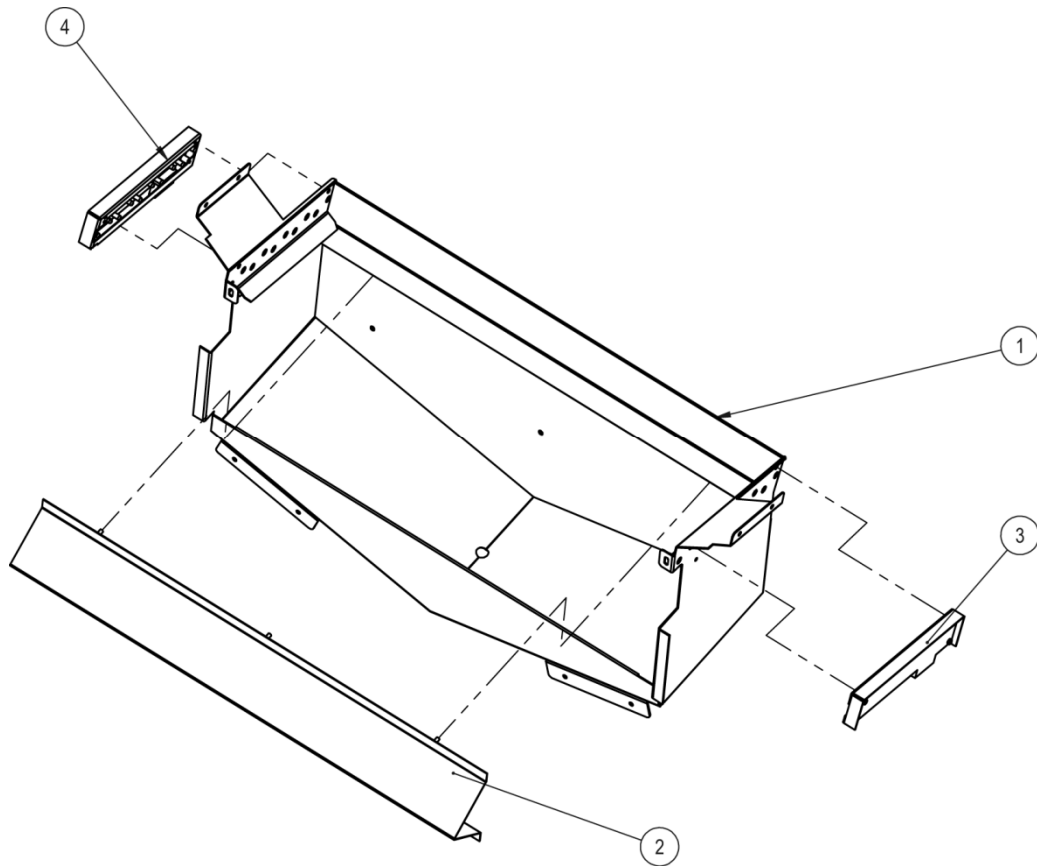
Ambient Delivery Bin Assembly



Parts List

| ITEM | PART NO. | DESCRIPTION |
|------|-----------|--------------------------------|
| 1 | SAI70009A | DELIVERY BIN ASSEMBLY (5-WIDE) |
| 1 | SAI70021A | DELIVERY BIN ASSEMBLY (4-WIDE) |
| 2 | SAI775 | VEND SENSOR ASSEMBLY, RIGHT |
| 3 | SAI779 | VEND SENSOR ASSEMBLY, LEFT |
| 4 | STI87055 | ANTI-THEFT BRACKET (5-WIDE) |
| 4 | STI58034 | ANTI-THEFT BRACKET (4-WIDE) |
| 5 | STI87049 | PANEL, DELIVERY BIN (5-WIDE) |
| 5 | STI58036 | PANEL, DELIVERY BIN (4-WIDE) |
| 6 | PLI943A | DELIVERY DOOR (5-WIDE) |
| 6 | PLI943 | DELIVERY DOOR (4-WIDE) |

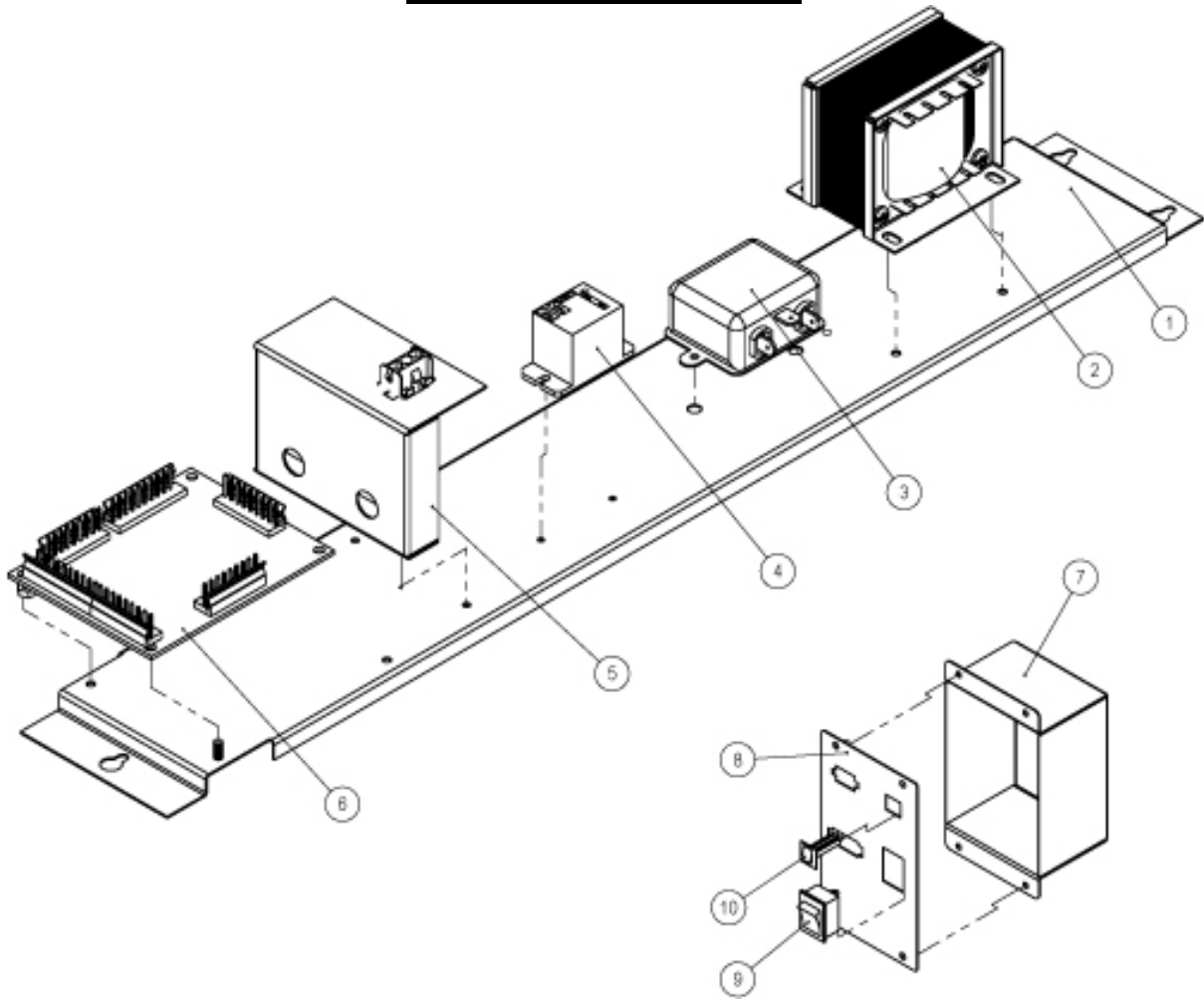
Refrigerated Delivery Bin Assembly



Parts List

| ITEM | PART NO. | DESCRIPTION |
|------|----------|--------------------------------|
| 1 | SAI87016 | DELIVERY BIN ASSEMBLY (5-WIDE) |
| 1 | SAI58010 | DELIVERY BIN ASSEMBLY (4-WIDE) |
| 2 | STI87055 | ANTI-THEFT BRACKET (5-WIDE) |
| 2 | STI58034 | ANTI-THEFT BRACKET (4-WIDE) |
| 3 | SAI775 | VEND SENSOR ASSEMBLY, RIGHT |
| 4 | SAI779 | VEND SENSOR ASSEMBLY, LEFT |

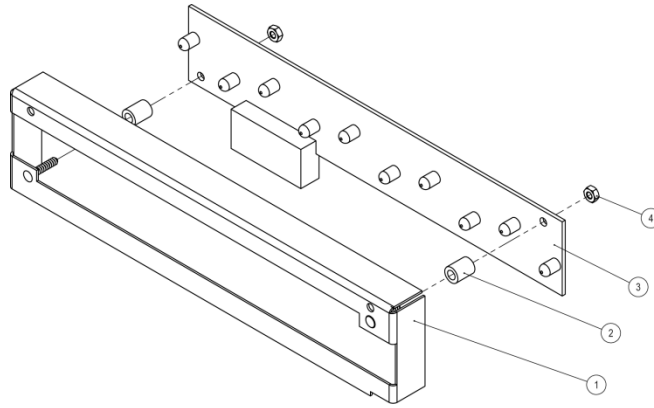
Electrical Panel Assembly



Parts List

| ITEM | PART NO. | DESCRIPTION |
|------|----------|----------------------------|
| 1 | ST187017 | ELECTRIC PANEL |
| 2 | ELI504A | TRANSFORMER |
| 3 | ELI946 | FILTER |
| 4 | ELI764 | RELAY |
| 5 | ST184018 | SWITCH BRACKET |
| 6 | ELI922 | AUXILARY BOARD |
| 7 | ST184019 | POWER BOX |
| 8 | ST184020 | ELECTRICAL BOX FRONT PLATE |
| 9 | ELI916 | ON/OFF SWITCH |
| 10 | ELI972 | CIRCUIT BREAKER |

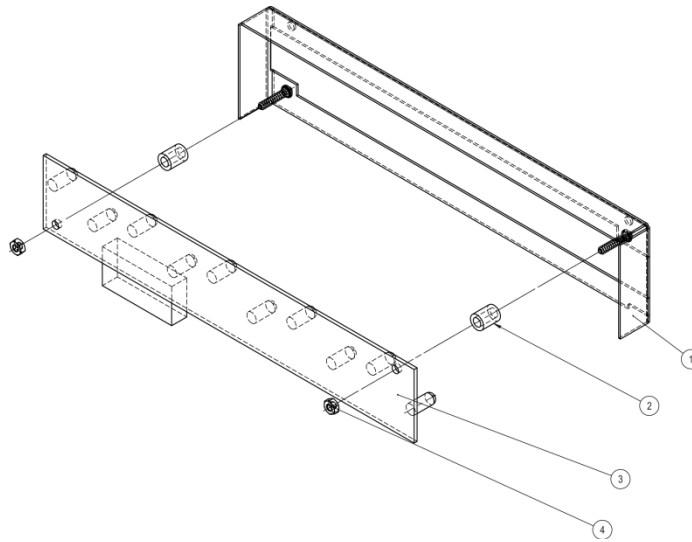
Vigilant Vend Sensor, Right Side Assembly



Parts List

| ITEM | PART NO. | DESCRIPTION |
|------|----------|----------------|
| 1 | STI70086 | SENSOR BRACKET |
| 2 | PLI609A | SPACER |
| 3 | ELI974 | EMITTER |
| 4 | FAI922 | NUT |

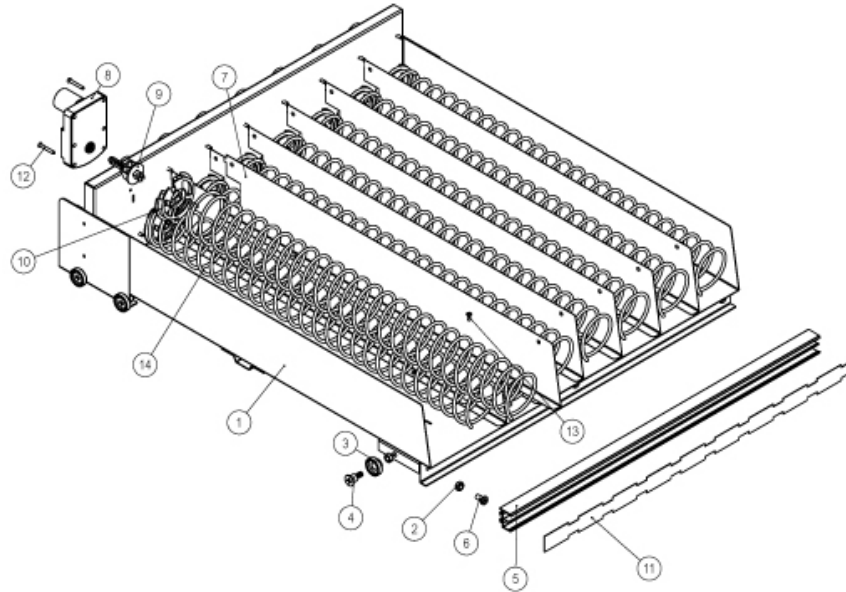
Vigilant Vend Sensor, Left Side Assembly



Parts List

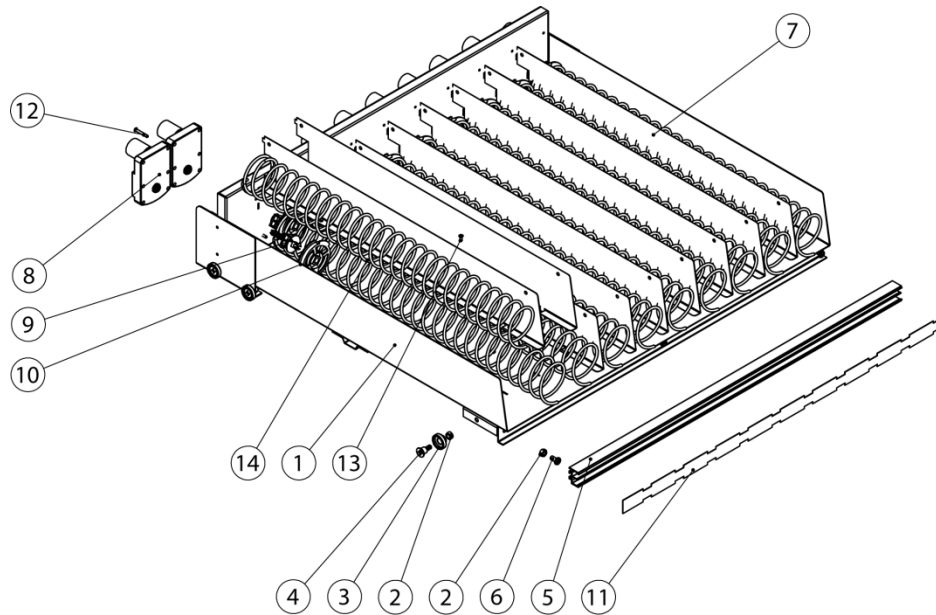
| ITEM | PART NO. | DESCRIPTION |
|------|----------|----------------|
| 1 | STI70086 | SENSOR BRACKET |
| 2 | PLI609A | SPACER |
| 3 | ELI2169 | DETECTOR |
| 4 | FAI922 | NUT |

8 SpaceTray Assembly, Confectionery (Candy)



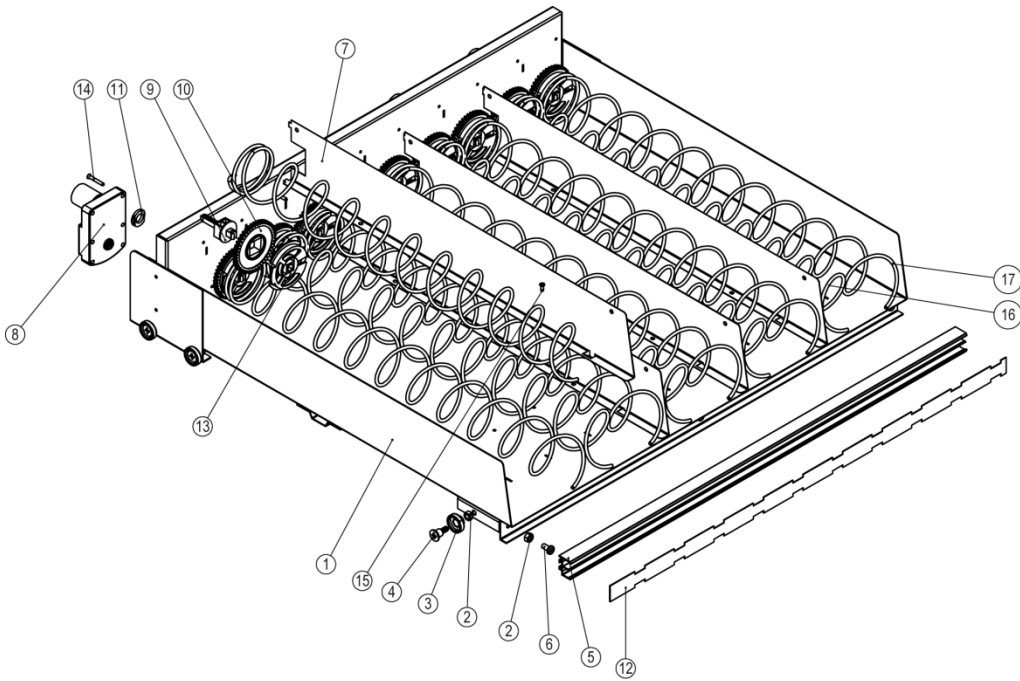
| ITEM | PART NO. | DESCRIPTION |
|------|-----------|------------------------------|
| 1 | SAI84024 | ASSEMBLY, WELDED TRAY |
| 2 | FAI923 | NUT, NYLOCK, M6 |
| 3 | PLI802A | WHEEL, TRAY |
| 4 | HAI602 | PIN, WHEEL, TRAY |
| 5 | PLC958 | PROFILE, PRICE SELECTION |
| 6 | HAI976 | PIN, PROFILE LABEL HOLDING |
| 7 | STI70010A | PARTITION, TRAY |
| 8 | ELC920 | MOTOR |
| 9 | PLI721C | SHAFT, GEAR MOTOR |
| 10 | PLI331 | HUB, COIL, RETAINER |
| 11 | PLI84001 | STRIP, PRICE SCROLL, HOLDING |
| 12 | FAI882 | SCREW |
| 13 | FAI892 | SCREW |
| 14 | WFI602 | COIL, 18 SPACE, RIGHT |
| - | WFI552 | COIL, 15 SPACE, RIGHT |
| - | WFI524 | COIL, 24 SPACE, RIGHT |

10 SpaceTray Assembly, Confectionery (Candy)



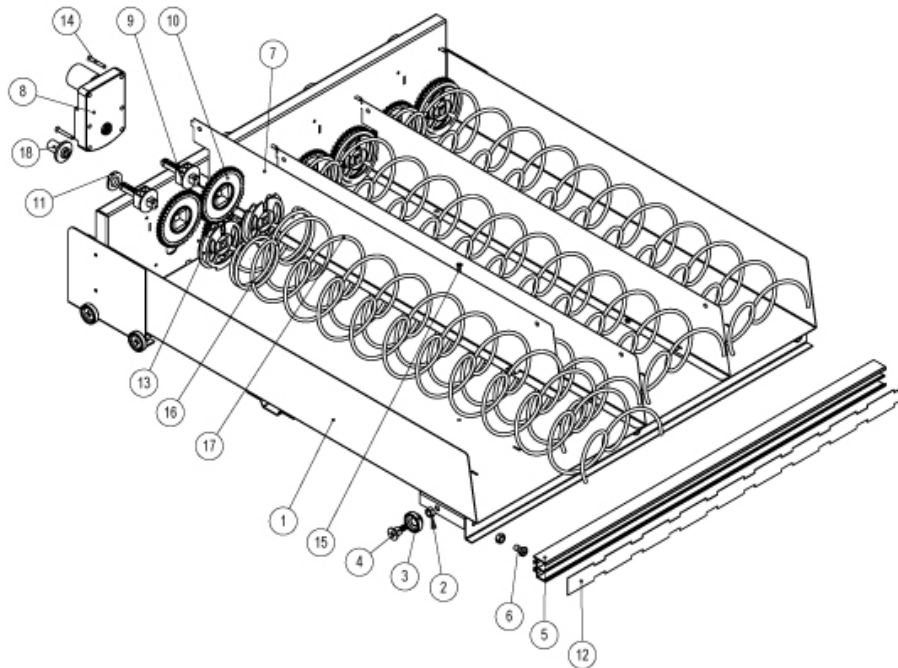
| ITEM | PART NO. | DESCRIPTION |
|------|-----------|------------------------------|
| 1 | SAI87041 | ASSEMBLY, WELDED TRAY |
| 2 | FAI923 | NUT, NYLOCK, M6 |
| 3 | PLI802A | WHEEL, TRAY |
| 4 | HAI602 | PIN, WHEEL, TRAY |
| 5 | PLC958 | PROFILE, PRICE SELECTION |
| 6 | HAI976 | PIN, PROFILE LABEL HOLDING |
| 7 | STI70010A | PARTITION, TRAY |
| 8 | ELC920 | MOTOR |
| 9 | PLI721C | SHAFT, GEAR MOTOR |
| 10 | PLI331 | HUB, COIL, RETAINER |
| 11 | PLI87001 | STRIP, PRICE SCROLL, HOLDING |
| 12 | FAI882 | SCREW |
| 13 | FAI892 | SCREW |
| 14 | WFI602 | COIL, 18 SPACE, RIGHT |
| - | WFI552 | COIL, 15 SPACE, RIGHT |
| - | WFI524 | COIL, 24 SPACE, RIGHT |

5 Space Tray Assembly, Snack Dual Coil



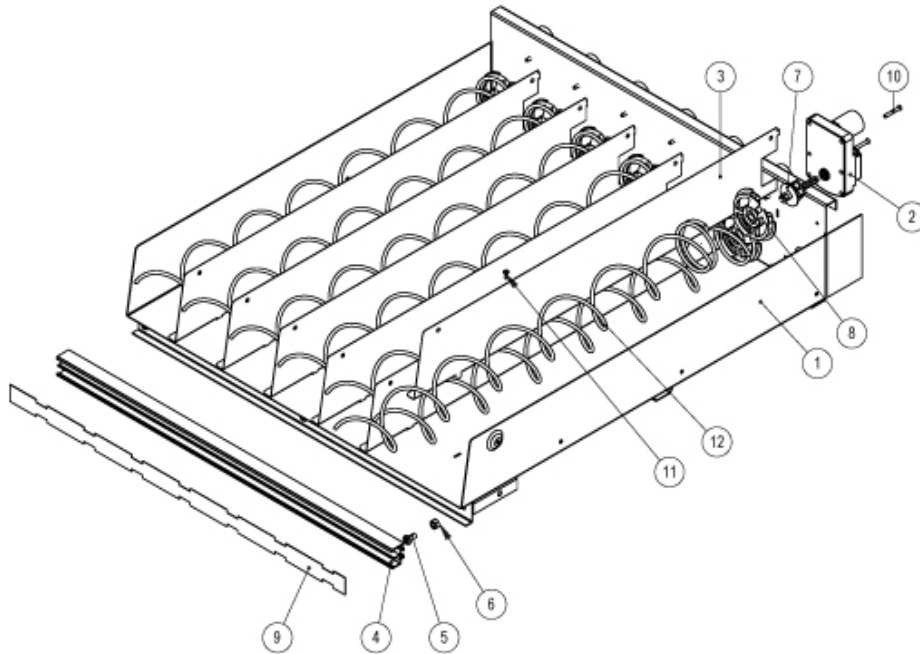
| ITEM | PART NO. | DESCRIPTION |
|------|-----------|------------------------------|
| 1 | SAI87041 | ASSEMBLY, WELDED TRAY |
| 2 | FAI923 | NUT, NYLOCK |
| 3 | PLI802A | WHEEL, TRAY |
| 4 | HAI602 | PIN, WHEEL, TRAY |
| 5 | PLC958 | PROFILE, PRICE SELECTION |
| 6 | HAI976 | PIN, PROFILE LABEL HOLDING |
| 7 | STI70010A | PARTITION, TRAY |
| 8 | ELC920 | MOTOR |
| 9 | PLI721C | SHAFT, GEAR MOTOR |
| 10 | PLI536 | GEAR |
| 11 | PLI332 | BUSH, RETAINER |
| 12 | PLI87001 | STRIP, PRICE SCROLL, HOLDING |
| 13 | PLI331 | HUB, COIL, RETAINER |
| 14 | FAI882 | SCREW |
| 15 | FAI892 | SCREW |
| 16 | WFI548 | COIL, 10 SPACE, LEFT |
| - | WFI549 | COIL, 10 SPACE, RIGHT |
| - | WFI568 | COIL, 12 SPACE, LEFT |
| - | WFI59 | COIL, 12 SPACE, RIGHT |

4 Space Tray Assembly, Snack Dual Coil



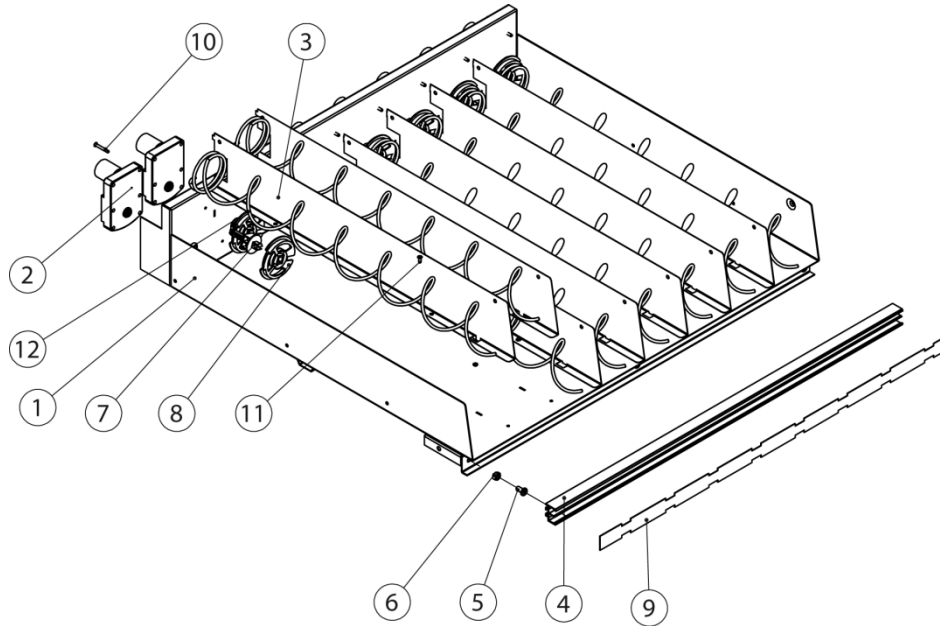
| ITEM | PART NO. | DESCRIPTION |
|------|-----------|------------------------------|
| 1 | SAI84024 | ASSEMBLY, WELDED TRAY |
| 2 | FAI923 | NUT, NYLOCK |
| 3 | PLI802A | WHEEL, TRAY |
| 4 | HAI602 | PIN, WHEEL, TRAY |
| 5 | PLC958 | PROFILE, PRICE SELECTION |
| 6 | HAI976 | PIN, PROFILE LABEL HOLDING |
| 7 | STI70010A | PARTITION, TRAY |
| 8 | ELC920 | MOTOR |
| 9 | PLI721C | SHAFT, GEAR MOTOR |
| 10 | PLI536 | GEAR |
| 11 | PLI332 | BUSH, RETAINER |
| 12 | PLI84001 | STRIP, PRICE SCROLL, HOLDING |
| 13 | PLI331 | HUB, COIL, RETAINER |
| 14 | FAI882 | SCREW |
| 15 | FAI892 | SCREW |
| 16 | WFI548 | COIL, 10 SPACE, LEFT |
| - | WFI549 | COIL, 10 SPACE, RIGHT |
| - | WFI568 | COIL, 12 SPACE, LEFT |
| - | WFI59 | COIL, 12 SPACE, RIGHT |
| 18 | PLI336B | RETAINER SLEEVE, GEAR |

7 Space Tray Assembly, Beverage



| ITEM | PART NO. | DESCRIPTION |
|------|-----------|---|
| 1 | SAI84028 | ASSEMBLY, WELDED TRAY, 7-SELECTION |
| 2 | ELC920 | MOTOR |
| 3 | STI70010A | PARTITION, TRAY |
| 4 | PLC958 | PROFILE, PRICE SELECTION |
| 5 | HAI976 | PIN, PROFILE LABEL HOLDING |
| 6 | FAI923 | NUT, NYLOCK |
| 7 | PLI721C | SHAFT, GEAR MOTOR |
| 8 | PLI331 | HUB, COIL, RETAINER |
| 9 | PLI84002 | STRIP, PRICE SCROLL, HOLDING FOR 7 SELECTION TRAY |
| 10 | FAI882 | SCREW |
| 11 | FAI892 | SCREW |
| 12 | WFI576 | COIL, 6 SPACE, RIGHT |

8 Space Tray Assembly, Beverage



| ITEM | PART NO. | DESCRIPTION |
|------|-----------|------------------------------|
| 1 | SAI87040 | ASSEMBLY, WELDED TRAY |
| 2 | ELC920 | MOTOR |
| 3 | STI70010A | PARTITION, TRAY |
| 4 | PLC958 | PROFILE, PRICE SELECTION |
| 5 | HAI976 | PIN, PROFILE LABEL HOLDING |
| 6 | FAI923 | NUT, NYLOCK |
| 7 | PLI721C | SHAFT, GEAR MOTOR |
| 8 | PLI331 | HUB, COIL, RETAINER |
| 9 | PLI87001A | STRIP, PRICE SCROLL, HOLDING |
| 10 | FAI882 | SCREW |
| 11 | FAI892 | SCREW |
| 12 | WFI576 | COIL, 6 SPACE, RIGHT |

LIMITED WARRANTY

Seaga warrants to the original purchaser that the equipment is free from defects in material and factory workmanship for a period of one (1) year from date of shipment.

This warranty applies only if the equipment has been serviced and maintained in strict accordance with the instructions presented in the Operator's Manual and no unauthorized service, repair, alteration or disassembly has been performed. Any defects caused by improper power source, poor water quality or pressure, an installed water filtration system not fully functioning, abuse of the product, accident, alteration, vandalism, improper service and maintenance schedules, neglecting to de-scale and sanitize on a regular basis, use of products or ingredients not allowed in the machine, corrosion due to use of non-approved detergents or cleaning solutions, or damage incurred during return shipment will not be covered by this warranty. Further, equipment that has had the serial number removed, altered or otherwise defaced will not be covered by this warranty.

Lighting components, refrigerant, glass, paint, decals, fuses, filters or hygiene replacement parts, labor and/or installation are not covered by this warranty.

Follow proper maintenance procedures and use of equipment, as described in the Operator's Manual provided on Seaga's web site at seagamfg.com, which include but are not limited to:

- Cleaning of equipment including regular maintenance
- Proper installation and location of equipment with respect for the indicated temperature and humidity levels
- Proper use of equipment including loading, programming and setup

THIS WARRANTY IS EXCLUSIVE AND IS GIVEN BY SEAGA AND ACCEPTED BY BUYER IN LIEU OF ANY AND ALL OTHER WARRANTIES, WHETHER EXPRESS OR IMPLIED, INCLUDING, WITHOUT LIMITATION, ALL WARRANTIES OF MERCHANTABILITY AND FITNESS FOR A PARTICULAR PURPOSE. ALL SUCH OTHER WARRANTIES ARE HEREBY EXPRESSLY DISCLAIMED BY SEAGA AND WAIVED BY BUYER. Seaga neither assumes nor authorizes any person to assume for it any obligation or liability in connection with the sale of said unit(s) or any part(s) thereof.

Repair or replacement of proven defective parts is limited to manufacturing defects demonstrated under normal use and service during warranty period. Contact Seaga's Customer Care Department to be assigned a Return Authorization (RA) number. Seaga requires complete information including the serial number(s) of the machine(s), date of purchase and description of the part and/or suspected defect. Seaga may also be contacted, with complete information, by phone: 815.297.9500, by fax: 815.297.1700 and also by email: customer care@seagamfg.com

Send defective part(s), assembly or complete unit, Attention to the RA Number, prepaid or delivered to:



700 Seaga Drive
Freeport IL 61032

Seaga will repair or replace, at our option, any covered part which meets the provisions herein during the warranty period. It is our discretion to replace defective parts with comparable parts. Seaga reserves the right to make changes or improvements in its products without notice and without obligation, and without being required to make corresponding changes or improvements in equipment already manufactured or sold.

SMI2456321