

SNACKSHOP 113

SNACKSHOP 113

SNACKSHOP 113

instruction manual for

SNACKSHOP 113

 **Automatic Products**
international, ltd.

75 WEST PLATO BOULEVARD • ST. PAUL, MINNESOTA 55107-2095

EXPRESS WARRANTY

Automatic Products international Ltd. (APi) expressly warrants these automatic merchandisers (the "Unit"), manufactured by it, to be free under normal use and service from defects in material or workmanship for a period of two (2) years from the date of delivery of this Unit to the original purchaser. This warranty extends only to the original purchaser of the Unit. The exclusive remedy for this warranty is limited to the repair or replacement, at APi's sole option, of any part or parts of the Unit that are returned to APi or to the authorized dealer or distributor of APi from whom the unit was purchased with all transportation charges prepaid, and which, on APi's examination, shall, conclusively appear to have been defective. This warranty does not:

- a. extend to any Unit, or part thereof, that was subjected to misuse, neglect, or accident by other than APi after its delivery to the original purchaser;
- b. extend to any Unit, or part thereof, that was modified, altered, incorrectly wired or improperly installed by anyone other than APi or used in violation of the instructions provided by APi;
- c. extend to a Unit which has been repaired or altered by anyone other than APi or authorized dealer/distributor;
- d. extend to a Unit which has had the serial number removed, defaced or otherwise altered;
- e. extend to plastic or glass windows, lamps, fluorescent tubes and water contact parts;
- f. extend to any Unit used outdoors
- g. extend to accessories used with the Unit that were manufactured by some person or entity other than APi.

API DISCLAIMS ALL OTHER WARRANTIES OF ANY KIND AS TO THE UNIT AND ALL WARRANTIES OF ANY KIND AS TO ANY ACCESSORIES. THIS DISCLAIMER OF WARRANTIES INCLUDES ANY EXPRESS WARRANTIES OTHER THAN THE LIMITED WARRANTY PROVIDED ABOVE AS TO THE UNIT AND ALL IMPLIED WARRANTIES OF MERCHANTABILITY AND FITNESS FOR A PARTICULAR PURPOSE AS TO THE UNIT AND ANY ACCESSORIES. UNDER NO CIRCUMSTANCES SHALL API BE RESPONSIBLE FOR ANY INCIDENTAL, CONSEQUENTIAL OR SPECIAL DAMAGES, LOSSES OR EXPENSES ARISING FROM OR IN CONNECTION WITH THE USE OF, OR THE INABILITY TO USE, THE GOODS FOR ANY PURPOSE WHATSOEVER. No representative of APi or any other person is authorized to assume for APi, or agree to on the behalf of APi, any other liability or warranty in connection with the sale of this Unit.

APi reserves the right to make any changes or improvements in its products without notice and without obligation, and without being required to make corresponding changes or improvements in Unit theretofore manufactured or sold.



75 WEST PLATO BLVD. • ST. PAUL, MINNESOTA 55107-2095

Snackshop 113 has been designed from superior engineering and with quality throughout. It has been built of rugged construction for many years of reliable trouble-free operation. (Note: For indoor use only.)

To achieve the most economical trouble-free operation from your Snackshop 113, it is recommended that this service manual be thoroughly read and instructions followed pertaining to all loading and servicing, etc., of the vendor.

Should you have any questions pertaining to this manual or the vendor, please contact your local Automatic Products Company distributor or write directly to:



75 WEST PLATO BLVD. • ST. PAUL, MINNESOTA 55107-2095

HEIGHT - 72" WIDTH - 38-7/8" DEPTH - 35"
FLOOR SPACE REQUIRED - 9.5 SQ. FT.
SHIPPING CONTAINER SIZE - 72.5 CU. FT.
POWER REQUIREMENTS - 115 V., 60 HZ.
STANDBY AMPERS - .7 OPERATING AMPERS - 3

table of contents

	Page
WARRANTY	i
AP 110 SERIES TRAINING	iii
CAPACITIES	1-2
UNPACKING	3
INSTALLATION	3-6
COMPONENTS	
1. Power Supply	7
2. Changers	7
3. Coin Mech Inventory	7
4. Mode Switch	7
5. Operate Mode	7
6. Control-Service Mode	7-10
7. Price Set Mode	10
8. Price Check Mode	10
9. Selection Panel	11
10. Vend Motors	11
11. Lighting System	11
12. Main Product Shelves	11
13. Delivery Bin	11
14. Removal of Gum & Mint Motors and/or Ejectors	11
15. Removal of Gum & Mint Shelf	11
16. Chilled Air Machine	12
17. Removal of Cooling Unit	12
CLEANING	12
OPTIONAL EQUIPMENT	
1. Ventilating Fan	12
2. Base Kits	12
3. Gum & Mint	12
4. Special Spirals	12
5. Soup Dispenser	12
6. Dollar Bill Validators	12
7. Debit Card Readers	12
8. Chilled Air Machine	12
9. Dual Spiral Shelf	12
10. Convertible Shelf	12
11. 114 Master	12
12. MIS Printer.....	12
13. Door Guard	12
PARTS LIST	
1. Door-Outside Front	13-14
2. Door-Inside Front	15-16
3. Cabinet	17-20
4. Swing-Out Panel Assembly	21-22
5. Snack Shelf	23-24
6. Candy Shelf	25-26
7. Convertible Shelf	27-28
8. Gum & Mint Shelf	29-30
9. Delivery Bin	31-32
10. Main Junction Box	33-34
11. Electrical Harnesses	34
12. Chill Machine Supplement	35-38
13. AP II Style	39
14. Cover-up Plate 3	40
16. High Tech Style	41
17. Tron II Style	42
18. Genesis Style	43
19. Connectors	44
20. MIS Printouts for 110 Series Snack.....	45
21. Troubleshooting.....	46-48
22. Connector Pinouts	49
SCHEMATIC	50-51

AP 110 SERIES TRAINING

OHMS	FUNCTION	BUTTON
3K	400 UP	A
6K	400 DOWN	B
9K	400 INSERT	C
12K	400 DELETE	D
15K		E
18K	DAY OF WEEK 800,900	F
21K	STEP 1 800,900	G
24K	STEP 2 % 800	H
27K	CLEAR, CLEAR PRICE	J
30K	RETURN TO SERVICE PRODUCT CODE	K

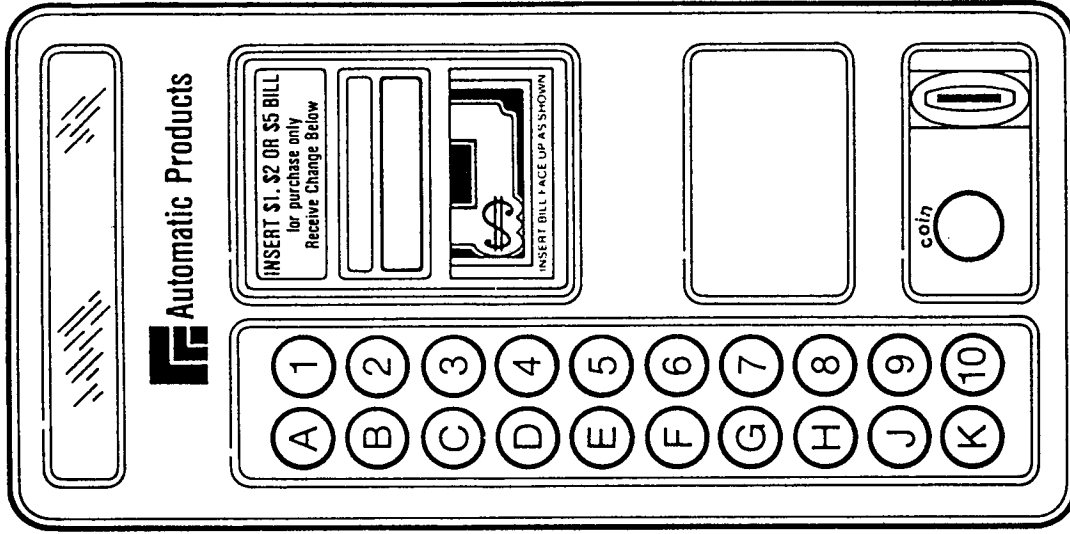

BUTTON	FIRST LEVEL FUNCTION	SECOND LEVEL FUNCTION	OHMS
1	\$.05 PAYOUT	WINNER, 400 RIGHT	33K
2	\$.10 PAYOUT	CLOCK, 400 LEFT	36K
3	\$.25 PAYOUT	ID #	39K
4	\$1.00 PAYOUT	MESSAGE, LANGUAGES	42K
5	ESCROW Y/N	PRODUCT CODE MIS	45K
6	FORCE Y/N	PROD CODE MIS CLEAR	48K
7	MULTI Y/N		51K
8	ACCOUNTABILITY	DISCOUNT TIMER	54K
9	TEST Y/N	SHUTDOWN TIMER	57K
10	2ND LEVEL ACCESS		60K

ADDITIONAL 2ND LEVEL FUNCTIONS:
 CODE 110 BUY ONE, GET ONE
 CODE 11C CLEAR BUY ONE, GET ONE
 CODE 125 SET COIN MACH INVENTORY
 CODE 12C CLEAR COIN MECH INVENTORY

NOTE: TOTAL MEMBRANE SWITCH RESISTANCE AT STANDBY = APPROX. 63KOHMS

Unless otherwise specified machine will be shipped with spiral assortment shown below.
 Figures in circles represent capacities each spiral.

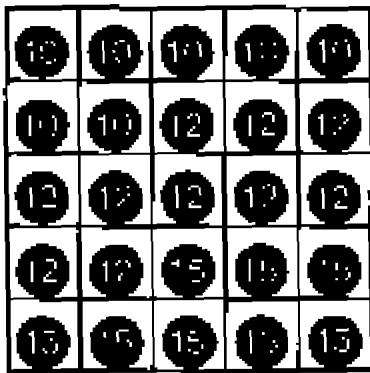

MODEL 113-525
 Capacity as shown: 310 units

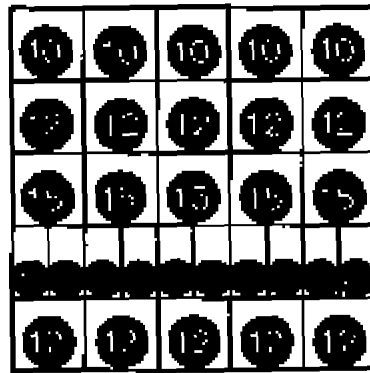

MODEL 113-530
 Capacity as shown: 437 units

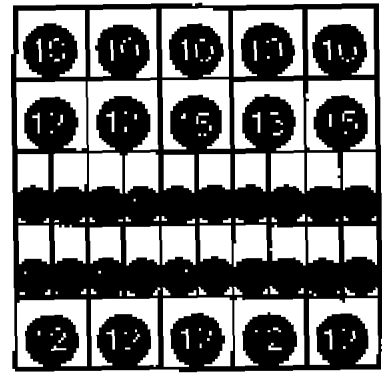

MODEL 113-535
 Capacity as shown: 551 units

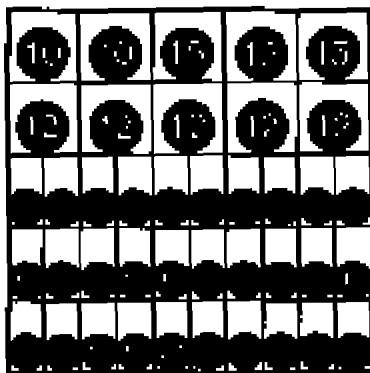

MODEL 113-540
 Capacity as shown: 577 units

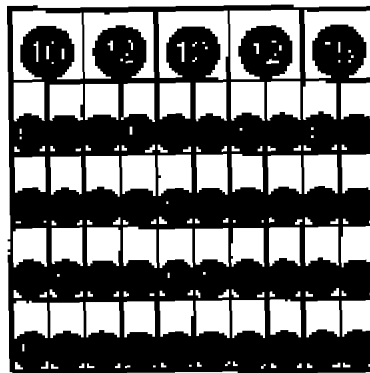

MODEL 113-545
 Capacity as shown: 775 units

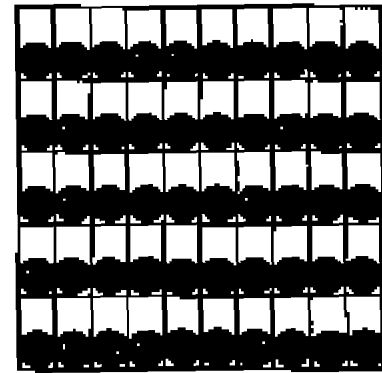

MODEL 113-550
 Capacity as shown: 854 units

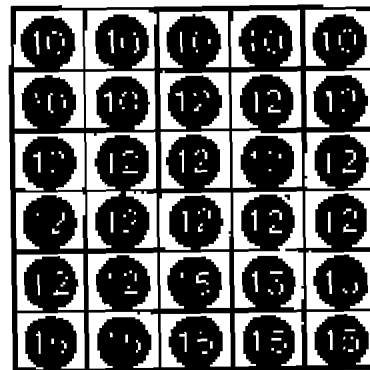

MODEL 113-555
 Capacity as shown: 370 units

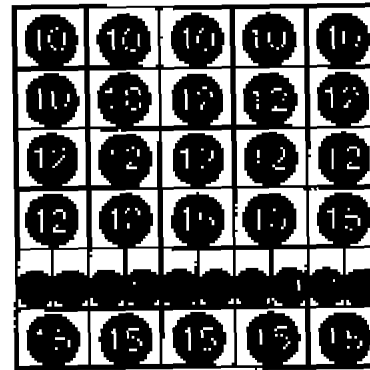

MODEL 113-565
 Capacity as shown: 502 units

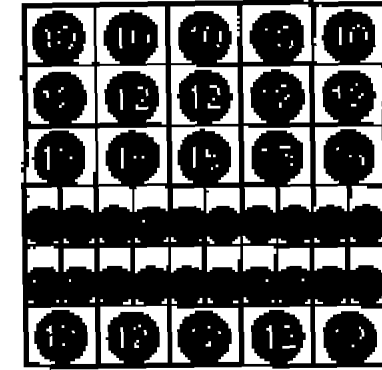

MODEL 113-540
 Capacity as shown: 617 units

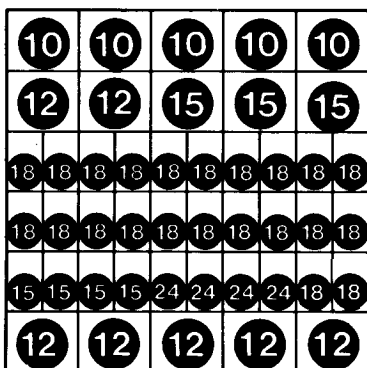

MODEL 113-645
Capacity as shown: 731 units

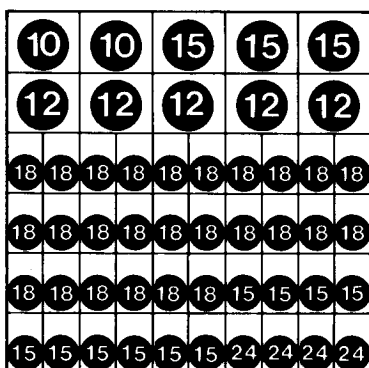

MODEL 113-650
Capacity as shown: 839 units

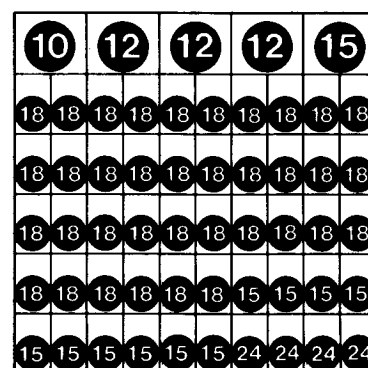

MODEL 113-655
Capacity as shown: 955 units

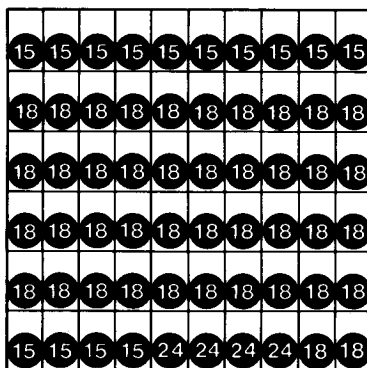

MODEL 113-660
Capacity as shown: 1062 units

SPECIFICATIONS

- HEIGHT - 72" WIDTH - 38-7/8" DEPTH - 35
- FLOOR SPACE REQUIRED - 9.5 SQ. FT.
- SHIPPING CONTAINER SIZE - 72.5 CU. FT.
- POWER REQUIREMENTS - 115 V., 60 HZ.
- STANDBY AMPERES - .7 OPERATING AMPERES - 3
- CHILLED MACHINES - USE 110Z OF 134A REFRIGERANT

PRODUCT SIZE CAPABILITY

SHELVES	HEIGHT	WIDTH of Snack Shelves Only	WIDTH of Candy Shelves Only	DEPTH OF Snack Spirals Only Choice:	DEPTH OF Candy Spirals Only Choice:
Top	7-3/4"	2 1/2" to 5 1/4"	1" to 2 1/4"	6 — Item Spiral 3-3/32"	6 — Item Spiral 2-7/8"
Second	7-1/4"	2 1/2" to 5 1/4"	1" to 2 1/4"	7 — Item Spiral 2-21/32"	7 — Item Spiral 2-1/2"
Third	6-5/8"	2 1/2" to 5 1/4"	1" to 2 1/4"	10 — Item Spiral 1-7/8"	9 — Item Spiral 1-15/16"
Fourth	7-1/4"	2 1/2" to 5 1/4"	1" to 2 1/4"	12 — Item Spiral 1-9/16"	10 — Item Spiral 1-3/4"
Fifth	6-3/4"	2 1/2" to 5 1/4"	1" to 2 1/4"	15 — Item Spiral 1-7/32"	12 — Item Spiral 1-1/2"
Sixth	6-1/4"	2 1/2" to 5 1/4"	1" to 2 1/4"	18 — Item Spiral 1"	15 — Item Spiral 1-1/8"
				30 — Item Spiral 1/2"	18 — Item Spiral 15/16"
				40 — Item Spiral 5/16"	24 — Item Spiral 11/16"
					30 — Item Spiral 1/2"
					40 — Item Spiral 3/16"

Ten selection shelves for candy and other narrow items fit on all six positions.

Spiral of one item capacity can be freely interchanged with any other of the same diameter.

Boxed items may need slightly larger clearances to vend properly.

Movable spacers available to adjust widths to ranges shown in each selection.

Gum-and-Mint Capacity. It is difficult to determine the true capacity due to variations of product size. The average capacity for the Gum-and-Mint Shelf is 170 items.

unpacking

The Snackshop 113 is assembled and packed so that a minimum amount of time is necessary for preparation to install it on location. The following steps are recommended to insure correct unpacking.

1. **Shipping Damage:** Thoroughly inspect the exterior of the carton for damage which may have occurred during shipment. Report any damage to delivering carrier and follow their instructions.

NOTE: Machines with refrigeration units delivered on their sides should be stood upright for 24 hours before the machine is plugged into an outlet.

2. Remove staples from lower edge and those at top of carton, and slit carton vertically at the taped corner. Open and remove carton. Remove the remainder of the packing material. On machines shipped with lock in place, the keys are located in the coin return cup.
3. **Remove Vendor With A Fork Lift Truck:** Remove the carton from the vendor. Open the door on the vendor and remove the hold down bracket at the front center of the cabinet base and lose the vendor door. From the front of the vendor tip the vendor backward and run forks under the cabinet.
4. **Removing Vendor Without A Fork Lift Truck:** Remove the carton from the vendor. Remove 1/4 " piece of plywood

located just behind the front legs, then open the door on the vendor and remove the hold down bracket at the front center of the cabinet base and close vendor door. From the front of the vendor tip the vendor back far enough to clear the wood strip across the front of the base. Slide vendor toward the back until the back legs are off the base and pull base out.

NOTE: Because the weight concentration is toward the back of the cabinet trucking and lifting should be done from the back. CAUTION should be taken when trucking from side.

5. On machines with lock in place, unlock, and turn handle to open door. When no lock is furnished, remove tape and turn handle. Swing door it its full open position.
6. Remove all packing tape and paper from various areas of machine and the shipping strap.
7. Warranty: **The warranty card is attached to the cover of this manual. It must be filled out in full and mailed at once to insure coverage.**
8. **IMPORTANT:** A set of anchoring brackets are sent with each machine. The kit is located in the bottom of the machine complete with instructions. It is recommended that this kit be installed to prevent shifting of the machine.

Kit, Part #660438

installation

1. **GENERAL:** In some locations, due to the size of this machine it is not possible to move the fully assembled machine through doors or narrow hallways. For such locations the door of this vendor can be removed, thus reducing the clearance required down to 32 inches.

DOOR REMOVAL: To remove the door, swing door to 90 degrees. Remove bolt and washer on door end of door stop. Unplug the light harness from the main interlock box. The upper hinge is secured to the cabinet by one bolt extending through the hinge from the inside of the cabinet. Remove the bolt with a 1/2 socket. Pull the door forward, the top hinge plate will slide out of its guide, freeing the door. Lift the door off of the lower hinge. Remove the left side panel extension which is held on by six screws. Remove the cabinet to door filler assembly which is held on by twelve screws. To install the door, reverse the above procedure.

2. **LEVELING THE MACHINE** on location is important for the proper function of the machine. The four leveling screws in the legs are the means of leveling the machine. After positioning the machine, level machine in front to rear and right to left directions. After leveling, turn front right (lock side) leveling screw in about one-half turn to drop this corner slightly to make the door easier to close and lock.

3. **VOLTAGE AND POLARITY CHECK.** It is important that this machine is hooked up to the proper voltage and polarity. Using a voltmeter, perform the following checks from the illustration below.

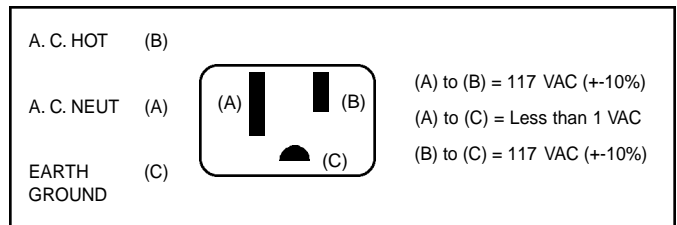

NOTE: Should the readings be different from above, have a certified electrician correct the problem.

4. **LOADING SNACK SHELVES:** Open door to full open position, push down on white plastic lock lever (Figure 1) to unlock shelf, holding both levers down. Grasp the shelf slightly and pull forward until shelf reaches its stop. The shelves tilt down (do not drop) to make loading easier. **Only one product shelf should be in the loading position at a time.** When returning a shelf, be sure the shelf is in its full home or vend position. Begin loading with the top shelf. Move it to the loading position. The height spacing for items is greatest in this shelf and the tallest bagged items should be placed there. Soft items, such as pastry, pies, etc., should be placed in the lowest snack shelf, making the drop distance as short as possible.

IMPORTANT: Product must not be forced into the spiral spaces but should fit freely. If the product is too tight, use a larger pitch spiral. The bottom of the product should be placed on top of the spiral wire that rests on the shelf surface (see Figure 2). The width of the product must be greater than the diameter of the snack spiral. If it is smaller, the product may fall through when it is in the front, ready to vend position.

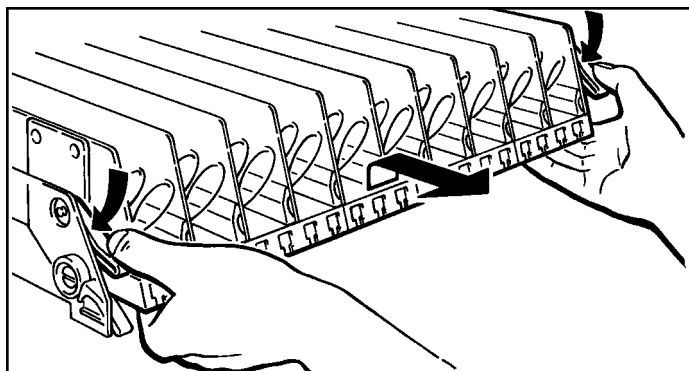

Figure 1. MOVING SHELF TO LOADING POSITION.

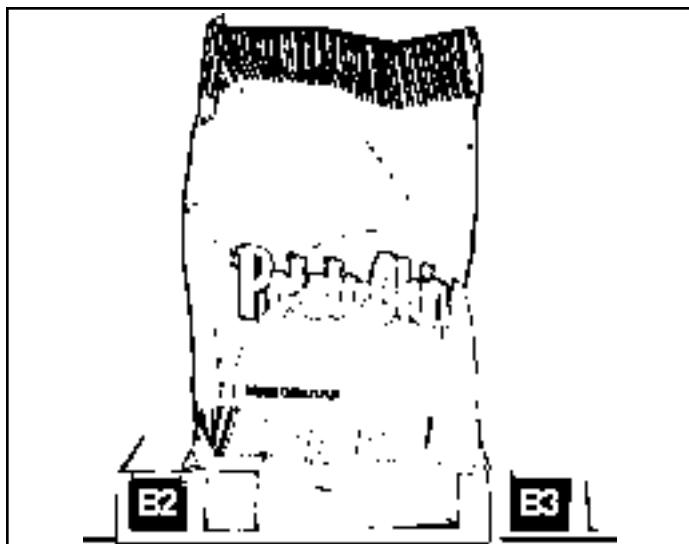

Figure 2. PLACEMENT OF PRODUCT ON MAIN PRODUCT SNACK SHELVES AND FRONT END POSITION OF SPIRAL.

5. **REMOVAL OF SPIRAL:** Grasp the front of the spiral and turn it clockwise. Lift the spiral up and off of the spiral lock. When replacing a spiral attach it around the tab on the spiral lock and turn the spiral counterclockwise to lock it in place. Be sure the front end of the spiral is positioned properly (with the front end of the spiral pointing downward on the left side) (see Figure 3). The spiral lock is attached between the spiral retainer tabs. Give a light forward pull on front of the spiral to check it is locked in place.

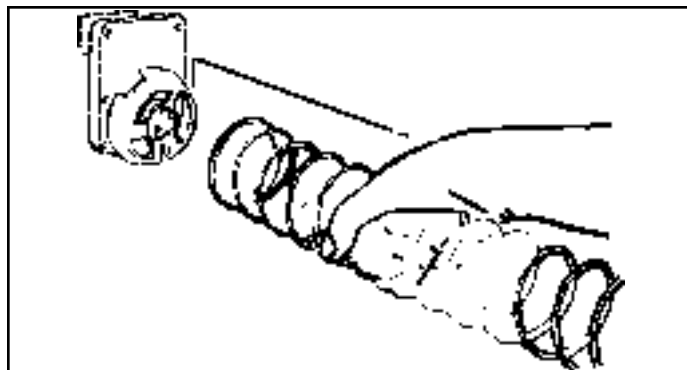

Figure 3. REMOVING AND INSTALLING SPIRAL.

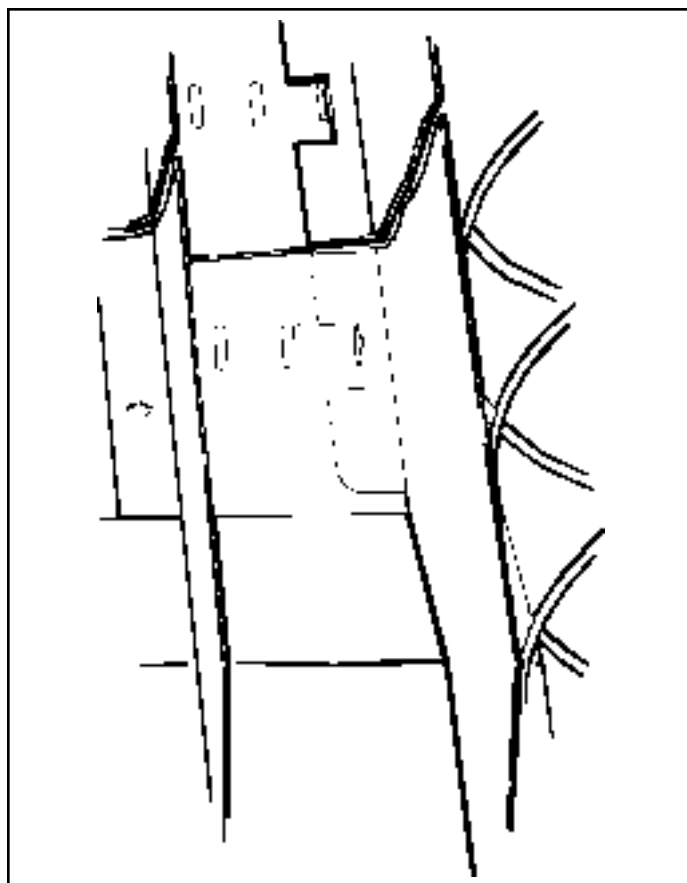

Figure 4. ALIGNMENT OF MOVEABLE PRODUCT SPACERS.

6. **PRODUCT SPACERS—5 SELECTION SHELF:** A product spacer is used to reduce the width of the product area and should be used on any 5-selection snack shelf where the product width is 4 1/2" or less. Spacers should fit within 1/8" of the product but should not fit tight against the product. There are three positions in each snack space where these spacers can be placed. To install the spacer, align the lock ears (on the lower edge of the spacer) with one of the three sets of slots (one front and one rear). (See Figure 4). Push the spacer to the rear to allow the ears to enter the slots, then allow the spacer to move forward. Be sure the ears are in the same set of slots, front and rear. (See Figure 4). Continue loading all spirals adjust with spacers where needed in the top shelf. Return the top shelf to the vend position and following this procedure load the remainder of the large spiral shelves. The shelf divider separating the right (lock side) column from the next column is movable to allow vending of products wider than 5 1/2" in the second column. If this is used the right column must be used to vend a narrower product.
7. **LOADING MAIN PRODUCT CANDY SHELVES:** The 10-selection (candy type) shelves are loaded similar to the 5-selection shelves except that the bottom of the product sits on the shelf in front of the spiral wire (see Figure 5) that rests on the shelf. These products must also fit properly product in the spiral space; do not force product into spiral.

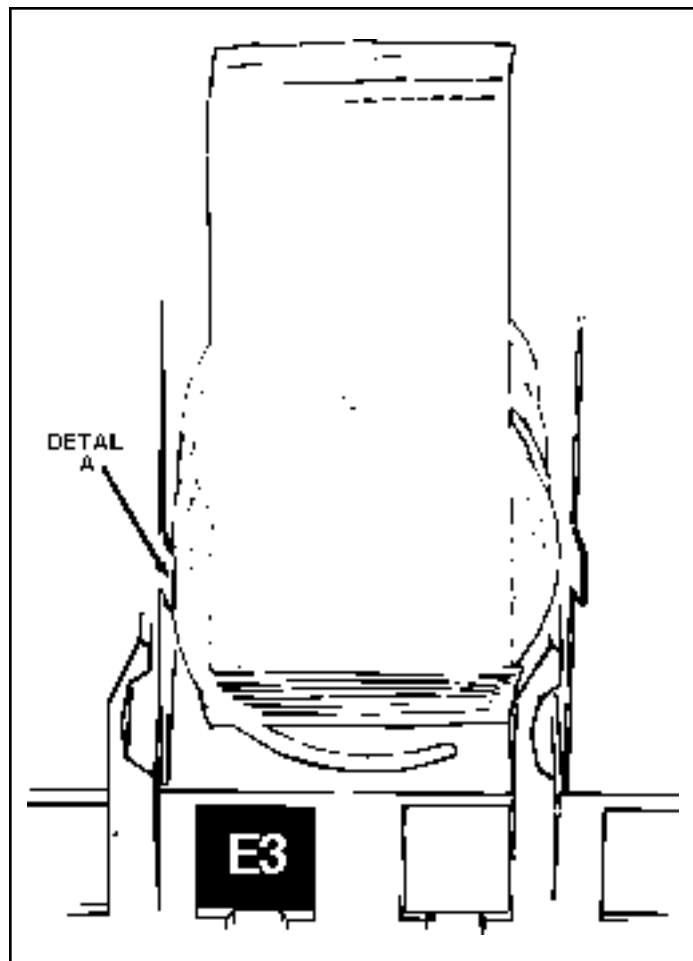

Figure 5. PLACEMENT OF PRODUCT ON MAIN PRODUCT CANDY SHELVES AND FRONT END POSITION OF SPIRAL.

These spirals are removed and installed the same as the large spiral (see Figure 3), except that the front end position is different (approximately 5 o'clock) (see Figure 5) and the front left side of the spiral must be behind the small tab located on the left side of the product space side wall (see Figure 5, Detail A).

8. **PRODUCT SPACERS—10 SELECTION SHELF:** The 10 -selection shelves are equipped with a product spacer (see Figure 6) that can be pivoted from the right side of each product space. These spacers should be pivoted out to hold the product upright, but not tight against the product. Leave about 1/8" clearance between the spacer and the product.

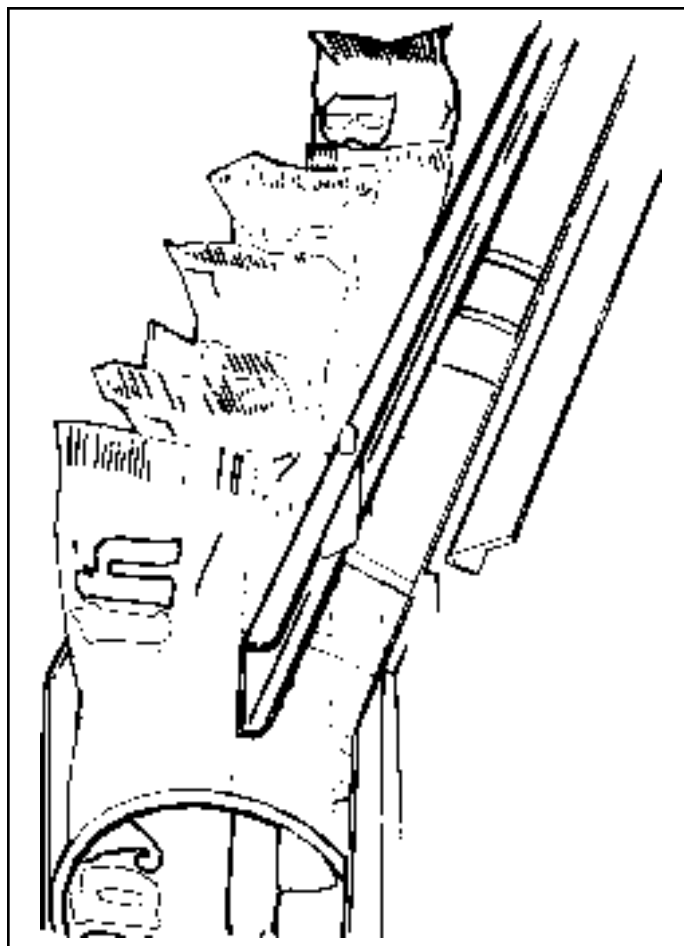

Figure 6. 10 SELECTION SHELF PRODUCT SPACER POSITIONED TO HOLD CANDY UPRIGHT.

9. **PRODUCT PUSHER:** The machine contains enough pushers for you to install a pusher on each candy spiral. This plastic part is designed to push the top of the product forward while it is vending, helping it fall from the shelf. It can also be used with products that have the wrapper end flap on the outside of the package. In this case, the pusher prevents these products from hanging on the spiral by spreading the flap. The pusher is installed approximately 210 degrees from the front end of the spiral with the tab extending forward (see Figure 7). Locate the pusher in its proper position, hold it against the spiral wire and push the semi-circular part around the spiral wire. Note: Not every selection spiral will need a product Pusher. (Example—Box Items)

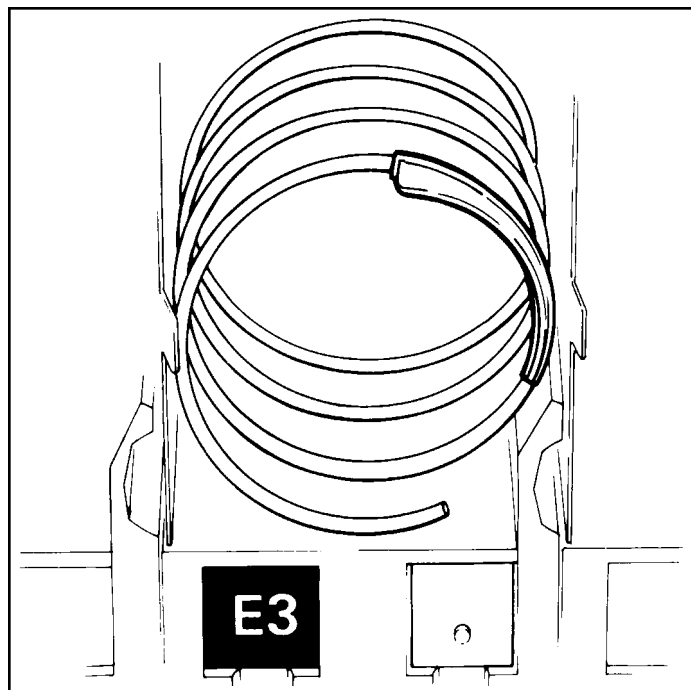

Figure 7. LOCATION OF PRODUCT PUSHER ON SPIRAL.

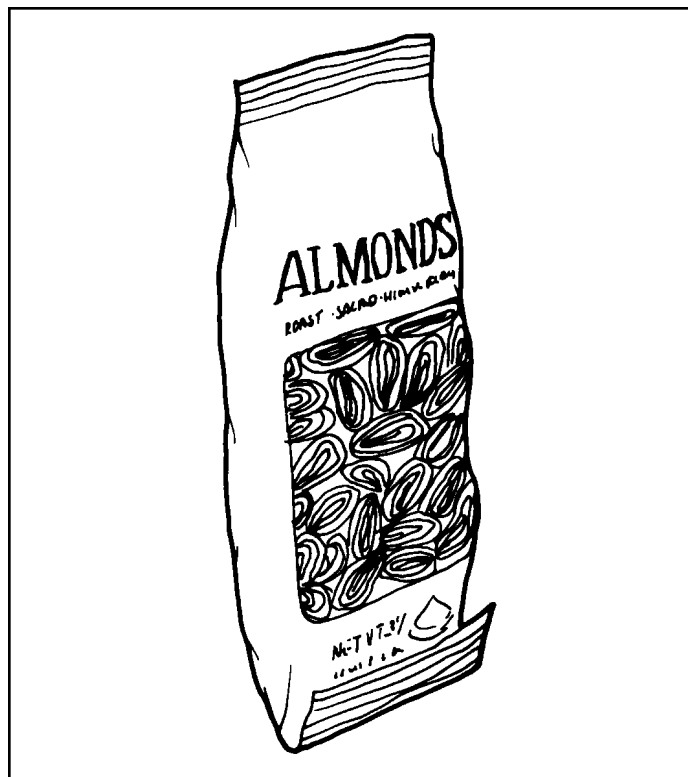

Figure 8. FOLD BAGGED ITEMS BOTTOM EDGE FORWARD AND UP.

10. BAGGED OR BOXED ITEMS in the 10-selection shelves if not loaded properly could be a problem. The sealed edge of the bag may get under the spiral wire causing the product to hang up after it has been vended. It is recommended that the lower edge of these types of product be folded forward and up (see Figure 8) next to the product before inserting into the spiral space. It is also recommended to use an 18 count spiral for bagged items because of the product settling to the bottom of the package.

11. CIGARETTE VENDING FROM SNACKSHOP 113: Cigarettes can be vended from the candy shelves using the (15 capacity) spiral for the soft pack regular, king, 100mm or 120 mm packs. The (12 capacity) spiral should be used for (box) packs.

12. LOCK PRODUCT SHELVES. After all the product has been loaded be sure all shelves are returned to their vend position behind the front roller guide.

13. INSTALL PROPER PRICE TABS into price tab holder for each selection in the main product area.(See Figure 9.)

14. LOADING GUM AND MINT. The Gum and Mint shelf is located below the Snack Shelves (optional). Unlatch the shelf by pulling forward the two metal latches located to the right and left of the shelf and pull forward. The cover can be pushed back to the rear for easy loading. The shelf contains four individual selections.

The first selection on the left contains two fillers for use with thin mints. (Roloids - Certs, etc.). These fillers can be removed for standard gum or mints.

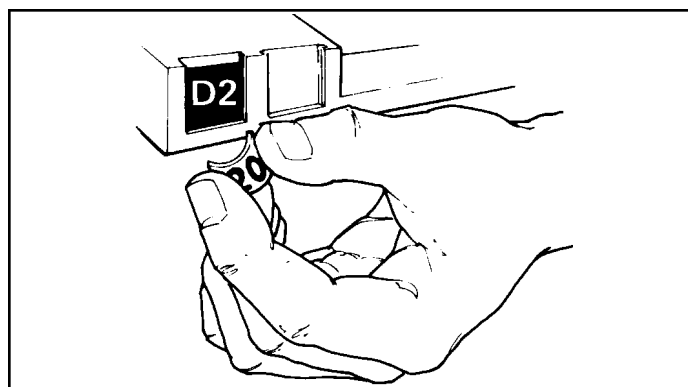

Figure 9. INSTALLING PRICE TABS

The two selections on the right of the Gum and Mint shelf also have fillers. These selections can be used for standard size gum and mints or the fillers may be removed for larger gum and mint products.

Each selection has a display hinge assembly which should be adjusted after the shelf is loaded. To adjust the display hinge, loosen the wing nut and slide the spring hinge of the flipper over the second product and fasten tightly.

1. POWER SUPPLY

The 115 volt power cord from the wall outlet comes into the machine and plugs into the bottom of the main junction box located to the right of the swing out panel. The other connections on the main junction box are for the light, fan (optional), 115 volt plug for bill validator and changer plug. The 115 VAC goes to the on & off switch and then to the circuit breaker. The 115 VAC goes to the transformer in which the voltage outputs (total of five) then goes to the P1 location on the control board.

2. CHANGERS

The Snackshop 113 can use a variety of either Mars or Coinco changers. The machine is wired for either 24 volt or 115 volt models. When using a 24 volt 12 pin changer either (Coinco 9302L) or Mars (TRC-6010) an adapter harness MUST be used and inserted into the main junction box. The Coinco (9302LF) & Mars (TRC-6010XV) are 15 pin, 24 volt chargers which do not need an adapter harness. The 115 volt models available are the Mars (TRC-6000), (MC-5000), and Coinco (9300L).

When installing the changer or removing the changer from the machine be sure to turn the power off. The changer is to be mounted on the three studs provided on the swing out bracket & fastened down. (Refer to the changer manufacturer on the installation and operation guide of the changer.) Load the changer payout tubes with coins and turn your power switch on.

Limit Coin Payout-Service Code 0130

Under certain conditions, a high vend price (greater than \$10.00) may cause the level of coins available for change payback in the coin mechanism to be repeatedly depleted and prevent further sales. If this situation exists, then you have the option to limit the amount of change that is returned to \$3.00 or if the amount of change to be returned exceeds \$3.00, permit the vend but return no change. This option is controlled as follows:

1. Press mode switch 1 time to access service mode.
2. Press 0130, display will now show "NO CHG Y/N" with either the Y or the N flashing. When the Y is flashing the amount of change to be paid is limited to \$3.00. When the N is flashing, the machine operates normally and returns the full amount of change required. Option is normally set with the N flashing from the factory.
3. Use any letter but K to toggle the Y/N back and forth to the required setting.
4. Press K to return to service and lock in the change.

CODE 133

Allows the user to turn tube leveling on or off. Once the code is entered, the display will show "TUBE_L Y/N" with the cursor at "Y" (tube leveling: the coin tube that has the highest height in coins is paid out first) or "N" (normal change payout: change will be paid out with the least number of coins). Press button "10" to alternate between the choices. Pressing the "K" button will lock in the information and return the user to the Service mode.

(NOTE: This code will not work with executive mechs.)

3. COIN MECH INVENTORY

This function allows the monitoring and adjustment of the coin levels in the tubes of the coin mechanism, as long as all coins have entered the coin mech through the coin entry chute and not through the tube slots, the display will show a current and accurate inventory of monies in the coin mech.

From the "service" mode, press #10, #1, #2, #5 the display will show "INV XX.XX" which represents the coin mechanism inventory. Deposit some coins through the coin entry chute to increase the inventory. Pressing the normal payout buttons, #1, 2, 3 or 4 will decrease the inventory. When or if the power to the machine

is turned off, the information is retained so that the coin mechanism and bill validator continue to operate properly. The scrolling display will reflect the current inventory as coins are added or subtracted. Entering 012C from service will reset the inventory to \$0.00 and reenter the mode to allow a new inventory to be established.

4. MODE SWITCH

The Snackshop 113 has only one mode switch that allows control of the machine functions. It is located on the control board. This switch will allow three modes of operation – operate (normal mode), control & service mode, and price setting mode.

5. OPERATE MODE

The operate mode is the normal vending position. This position allows three functions:

- A. Pressing a selection will display the price of that selection. If any selection is not operating or not programmed in the machine a beep will sound and the display will read "Make another selection".
- B. Insertion of coins will display "Credit" and the amount.
- C. Customer instructions will appear on the display "Make another selection", "Use correct change", or "Check selection price" for those three conditions which might occur.

NOTE: If in any of the other modes of operation the mode switch or coin return has to be depressed to get back into the operate mode.

6. CONTROL-SERVICE MODE

The mode switch on the control board should be pressed once to enter the control-service mode. Upon pressing the switch all non-operating selections will be displayed. Next, continue to press the letter "K" to advance any other problem with a failed motor until you reach "Service". Entering into the service mode use of the selection buttons (1-10) is necessary for the following functions.

Press #1 – Dispenses 5¢ from the changer.

Press #2 – Dispenses 10¢ from the changer.

Press #3 – Dispenses 25¢ from the changer.

Press #4 – Dispenses \$1.00 from the changer.

Press #5 – Displays escrow y/n.

(NOTE: y/n use is for yes or no. Pressing #5 changes the position of the flashing letter. This display indicates which way the bill will be taken.)

Press #5 – Escrow y/n. In the "yes" mode the bill will be escrowed so if you push the coin return button you will get that bill back. If a selection is priced over a dollar (Example: A1 is \$1.25) the bill validator will not take a second dollar. You must use a dollar and insert change. In the "no" mode the bill will not be escrowed (goes directly into the stacker) so if you push the coin return you will get back change.

(NOTE: The coin mechanism must contain enough coins in all three coin tubes for this function.)

Press #6 – Displays force y/n. (NOTE: y/n use is for yes or no. Pressing #6 changes the position of the flashing letter.) Pressing #6 in the "yes" mode when pricing in the machine is above a dollar, the bill will be taken and you must buy a selection. In the "no" mode allows you to make a selection or if you change your mind push the coin return button to get your money back.

Press #7 – Displays multi y/n. (NOTE: y/n use is for yes or no. Pressing #7 changes the position of the flashing letter.) When multi vend is in the "yes" mode after a dollar bill or change is inserted, will register the amount on the digital display. When a

selection is made the amount on the digital display will deduct the price of that selection. At this time the total cash will be displayed of the amount left of that dollar so that another selection may be made without inserting more money. You, therefore, can push the coin return for your change or make as many selections you want to until the digital display reads below the lowest selling price in the machine, then the rest of the money will be paid automatically. **(NOTE:** When using the shoppers mode, there is also a delay time incorporated on the control board. If a customer does not make another selection after a period of 10-15 seconds the changer will pay back automatically.)

Press #8 – The display will show cash 000 (total cash sales). Pressing #8 again gives the amount of vends 000 (total vends). Pressing #8 will show (total bills) 000 accepted. Pressing #8 will show the amount of times the machine has been reset.

Press #9 – Displays free vend y/n. **(NOTE:** y/n use is for yes or no. Pressing #9 changes the position of the flashing letter). When using the “yes” mode push the coin return button and you can now free vend or test each motor. **(NOTE:** Test vend will not add money or vends to cash sales or total vends.) Closing the door removes the test mode to the “no” mode automatically.

Press #10 – The display will appear blank. This will allow you to program from 100 mode through 900 mode in the machine. **(NOTE:** When programming into different modes, the #10 button will be 0.) Re-entry from one mode back to the blank display can be accomplished by pressing “K” (which puts you back in service) then pressing #10 (blank display) and programming another mode. From the Service Mode - press #10 (blank display.)

100 MODE – Winner mode. Press #1-#10-#10 which is the **winner mode**. This function enables you to program the machine to give “free” products every so many cash vends. Setting this program at 001 will set the machine on free vend. (Every vend will give you that product and then return the money.) Setting on 012 will give a “FREE” product every twelve vends. “FREE” products can be set from 001 to the maximum range of 255 vends. **(NOTE:** Pressing the letter “K” will return you to the start of the service mode.)

200 MODE – Clock mode. From the service mode, press #10 (blank display). Press #2-#10#10 which is in the **clock mode**. This function enables you to set or change a clock. (Used for discounts and machine shut down time.) After pressing 200, the digital display will show 00 which represents the last two numbers of the year. Press the numbers for the present year. Press the letter “J” and 00 will appear which represents the month. Press 01 to 12 for the month. Press “J” again and 00 will reappear for the day. Press the numbers 01 to 31 for the day. Press “J” and 00 will be displayed for the hour. Set the hour from 00 thru 23; Midnight being 00 to 01 a.m. Press “J” and 00 will reappear for minutes. Use 00 to 59 for the current minute. Lock the clock times in by pressing “J”. **(NOTE:** Pressing the letter “K” will return you to the start of the service mode.)

300 MODE – Identification mode. From the service mode-Press #10 (blank display). Press #3-#10#10 which is the **identification mode**. This function enables you to set a machine identification number. The display will show 8 zeros and by pressing any combination of numbers (maximum of 8 numbers) you can enter a machine identification number. **(NOTE:** This identification number will appear in the sales data mode 500.) **(NOTE:** Pressing the letter “K” will return you to the start of the service mode.)

400 MODE – Message mode. From the service mode-Press #10 (blank display). Press #4-#10#10 which is the **message program**. This function enables you to change the scrolling message “Have A Nice Day” to any message you want to program. Alternative languages are also available by pressing:

English	#4 #10 #1	French	#4 #10 #6
German	#4 #10 #2	Danish	#4 #10 #7
Spanish	#4 #10 #3	Swedish	#4 #10 #8
Italian	#4 #10 #4	Russian	#4 #10 #9
Dutch	#4 #10 #5	Slovenia	#4 #10 #10

Entering into the message program (any language) one of the letters will be flashing. The flashing letter is the character to be changed. The character may be moved to the right by pressing #1 or to the left by pressing #2. When the character you want changed is flashing use the letter “A” to change it. Passing up the character (letter or symbol) you can reverse the scrolling direction by pressing the letter “B”. Complete your message by moving and changing each character. Pressing the letter “C” you can insert a new letter. Pressing the letter “D” will delete the flashing character and move the whole message to the right (out of view) which delays the scroll from coming on the display. Your message can be programmed up to 137 characters. **(NOTE:** To eliminate your programmed message in any language and have the original “Have A Nice Day” appear you just program (401-408). When not using the message display as an option, the display can display the exact time (set in the clock mode - 200). Displaying the time can be achieved by moving the flashing character to the far left with button #2 and entering the “ø” character with button “A”. **(NOTE:** the “ø” character can be used to delete all or part of the message.) Exit the message program (close door, push operate button, depress coin return, or push the button “K” to return to “Service” mode).

500 MODE – Sales data mode. From the Service mode, press #10 (blank display). Press #5-#10#10 which is the display **sales data mode**. The machine identification number, if programmed in the (#300) mode, will appear. **(NOTE:** The display sales data can be retrieved only when using the product codes. See price setting mode.) Press button #1 and the first product code will be displayed with the number of vends of that product code. Press number #1 for the next product code and sales data. Continue pressing #1 until you reach the machine identification number. Press “K” to return to the “Service” Mode.

501 MODE – MIS Print – Allows you to print to a hand held printer the information on page 46 by using the following procedure.

- A. POWER DOWN MACHINE
- B. CONNECT HARNESS PART#680509 TO P10 TERMINAL ON BOARD AND THE 25 PIN RS 232 END TO PRINTER.
- C. POWER UP MACHINE
- D. ENTER SERVICE MODE
- E. PRESS 10 DISPLAY (DISPLAY WILL GO BLANK)
- F. PRESS 5-0-1 TO INITIATE PRINTOUT MODE
- G. DISPLAY WILL SHOW MIS PRINT AND THE PRINTER WILL START.
- H. IT WILL AUTOMATICALLY TERMINATE AT THE END OF THE DATA TRANSMISSION, AND RETURNS TO THE SERVICE MODE. (A SERIES OF THREE BEEPS ARE PRODUCED, SIGNIFYING THE END OF DATA TRANSMISSION.

600 MODE – Reset sales data mode. From the Service Mode-Press #10 (blank display). **CAUTION:** Press #6-#10-#10 which is the **reset sales data mode**, resets all vends programmed with product codes retrieved in the 500 mode.

700 MODE – Bill Value Set Up: From the Service Mode, press #10 (blank display). Press #7-#10-#10 which is the 700 mode. Display will show “B VALXXXX” once this code has been entered. You can enter a 4 digit number representing the value of the bill.

(Example: for U.S. Dollars, the value is 100.) Note that the credit is incremented by the entered value for each pulse coming from the bill acceptor. When the XRAM is initialized, the bill value is set to 100. When a TRC mech is connected to the controller, the controller ignores the bill value entered and uses 100 (note that it ignores, not alters, the entered value).

800 MODE - Whole Machine Discount: This function allows you to discount the selling of merchandise for the entire machine at a percent and up to three time periods per day (A, B, C,) and up to seven days of the week. (NOTE: The time must be programmed in the 200 mode for this feature.)

Step #1 – From the Service Mode, press #10 (blank display). Press #8-#10-#10 which is the 800 mode (machine or selection discount mode). The “STRT” will appear (this will automatically put you in time period “A”). Enter the time when you want the discount of the entire machine to start. The start time is set on a 24 hour (military) basis starting with 00:00 as midnight (Example: 1:00 p.m. as 1300 hours).

Step #2 – Press the “G” button once and “STOP” will appear. Enter the stop time (NOTE: The “STOP” time is set for the machine to go back to full price of the products).

Step #3 – Press the “H” button and “PRCT” will appear. Select the (%) percent of discount desired using the number buttons to enter the discount for the “Whole Machine”. (Setting at 100% the products will sell for free.) (NOTE: Clearing or cancelling all of the 3 steps can be done by pressing the “J” button.)

Step #4 – If a discount is only desired on certain days of the week, it can be programmed by pressing the “F” button. Pressing “F” the display will show DY0000000. This represents each day of the week “Sunday through Saturday” from right to left.

Display Shows:

“0” meaning “OFF”
“1” meaning “ON”

DY	0	1	0	1	0	1	0
	S	F	T	W	T	M	S
	A	R	H	E	U	O	U
	T	I	U	D	E	N	N

Pressing button “1” or button “10”-“0” will set each “day” on or off for discounting.

Example: Shows Monday, Wednesday and Friday - machine will be on discount for time period “A”.

Display Shows:

DY	0	1	0	1	0	1	0
	S	F	T	W	T	M	S
	A	R	H	E	U	O	U
	T	I	U	D	E	N	N

Step #5 – Press button “K” to return to the service mode and lock in the “A” discount time period. Setting up for more than one discount time period by using buttons B, C, and D. Example: After setting the time period “A” with the four programming steps, press the letter “B” to enter its time period and repeat the four steps in programming the discount time period, the display will read “Buy Now and Save X%” at the different times.

800 MODE - Discount by Selection: This function allows you to discount the selling of merchandise by selection at a discount price. Prices can be set up to four time periods per day (A, B, C & D) and up to seven days of the week.

Step #1 – From the service mode, press #10 (blank display). Press #8-#10-#10 which is the 800 mode (selection discount mode). The “STRT” will appear (this will automatically put you in time period “A”). Enter the time when you want the discounted

price per selection to occur. The start time is set on a 24 hour (military) basis starting with 00:00 as midnight (Example: 1:00 p.m. as 1300 hours).

Step #2 – Press the “G” button once and “STOP” will appear. Enter the stop time for the discounted prices. (NOTE: The stop time is then set to put the machine back to the original prices.)

Step #3 – Press the “H” button and “PRCT” will appear. Enter buttons #1-#10-#1.(101)

Step #4 – If a discount is only desired on certain days of the week, it can be programmed by pressing the “F” button. Pressing “F” the display will show DY0000000. This represents each day of the week “Sunday through Saturday” from right to left.

Display Shows:

“0” meaning “OFF”
“1” meaning “ON”

DY	0	0	0	0	0	0	0
	S	F	T	W	T	M	S
	A	R	H	E	U	O	U
	T	I	U	D	E	N	N

Pressing button “1” or button “10”-“0” will set each “day” on or off for discounting.

Example: Shows Monday, Wednesday and Friday - machine will be on discount for time period “A”.

Display Shows:

“0” meaning “OFF”
“1” meaning “ON”

DY	0	1	0	1	0	1	0
	S	F	T	W	T	M	S
	A	R	H	E	U	O	U
	T	I	U	D	E	N	N

Step #5 – Press mode switch once (control board) to access price set mode. The display will show “PR”.

Step #6 – Press the “K” button which will access the product code setting. Press #9-#9-#9 the display will show “PRD1 00.00”. This is where all “Cash” discounts are set for time period “A”.

Step #7 – Enter the cash discount desired (Example: 00.05, 00.10, etc.) Using letter and number combinations, you can program the discount per selections similar to set pricing. When the discount is programmed in the selling price of a selection it will be equal to the original price minus the cash discount. You can have more than one cash discount amount in a single time period by repeating step #7.

Step #8 – Setting extra time periods with discounts on selections by using Steps #1 through #7. When in step #1 pressing #8-#10-#10 which is the 800 mode use button “B” for PRD2, button “C” for PRD3, and button “D” for PRD4. When the discount time periods occur, the display will show “Buy Selection A1 for 00.XX”, “Buy Selection B7 for 00.XX” “Have A Nice Day”. All discounted selections will be displayed followed by the normal user message and then repeated.

Clearing Discount by Selection: IMPORTANT: Clearing discounts on individual selections is a *two step* procedure. Both steps, if not programmed, will leave previous discounted selections with any discounted selections being set in the program.

Step #1 – Press mode switch once (control board) to access the service mode. Press #10-#8-#10-#10 (0800) the display will show “START XX: XX” time period “A”. Clearing the time period “A” of discounts by pressing the letter “J”, the display will be blank. Clearing other time discounts by pressing “B” time period and pressing the letter “J”, same on “C” and “D” time periods. After

clearing the time periods, press "K" to return to the service mode and lock in the information.

Step #2 – Press mode switch once (control board) to access the price set mode. The display will show "PR". Press the button "K" which will access you into the product code setting. Press button #9-#9#9 which will display "PRD1 00.00. This is where all cash discounts are set for period "A". Press button "J" to clear the cash discounts for time period "A". Press button "K" to advance to time period "B" which will show "PRD2 00.00" on the display. Press button "J" to clear time period "B". Repeat the step for "C" time period PRD3 and timer period "D" PRD4.

900 MODE – Shut-down mode. From the service mode, press #10 (the display will be blank). Press #9-#10-#10 **shut-down mode.** This function enables the machine to be turned off at a certain time and then be turned back on at a given time. (**NOTE:** The machine must be programmed in the 200 mode to use this feature.) The machine can be programmed to be turned off and then back on in four different time periods (A, B, C and D) and any day of the week.

The display will show "STRT". (This automatically puts you in time period "A"). Enter the start time by pressing the buttons using the clock (military) from 00:00 as midnight to 23:00 hours as 11:00 p.m.

(**NOTE:** The "Start" time is for the shut down time and the "Stop" time is for resuming time.) Press button "G", it will display "Stop" time. Enter the stop time. Press button "F", the display will show DY0000000. This simulates days of the week Sunday through Saturday (right to left). Use button #1 for on and #10 as 0 for off.

"0" meaning "OFF"
"1" meaning "ON"

DY	0	1	0	1	0	1	0
	S	F	T	W	T	M	S
	A	R	H	E	U	O	U
	T	I	U	D	E	N	N

Example: Shows Monday, Wednesday, Friday machine will shut down. For START and STOP time, set in "A" period.

Display Shows:
"0" meaning "OFF"
"1" meaning "ON"

DY	0	1	0	1	0	1	0
	S	F	T	W	T	M	S
	A	R	H	E	U	O	U
	T	I	U	D	E	N	N

Setting more than one time period by using buttons "B", "C" and "D", Example: After setting time period "A", press button "B". Press button "G", the display will show "STRT". Enter the time for period "B". Press button "G", the display will show "STOP". Enter the stop time for period "B". Press button "F", the display will show DY0000000. Set days you want period "B" to shut down the machine. (See chart, above). Continue if needed for periods C & D by using the same procedure. During the shut down time, the display will scroll "Machine Use Not Allowed until XXXX." Service functions are allowed during the shut down times.

Previous machines had to be programmed to start and stop on the same day. A software change on the control board makes it possible now to start on one day and to stop on the next day. This feature may be used in both the 800 (discount) or 900 (shut down) mode. The day of the stop time does not need to be specified by using the "F" button. The board will automatically stop the 800 or 900 feature the day after it is started.

Example: Periods of discount or shutdown Monday 10:00 p. m. to Tuesday 2:00 a.m., Thursday 10:00 p.m. to Friday 2:00 p.m.

Display Shows:
"0" meaning "OFF"
"1" meaning "ON"

DY	0	1	0	1	0	1	0
	S	F	T	W	T	M	S
	A	R	H	E	U	O	U
	T	I	U	D	E	N	N

Two for One Option Mode – This function will allow you to vend two products for the price of one. From the service mode – Press #10 (blank display). Press #1-#1-#10, the "_->_" will appear on the display. Select the purchased selection letter (A-G) then the number (1-10). The display will then show your selection letter (A-G) then the number (1-10). The display will then show your selection on the display (Example: "B3->_") Now select the free selection letter and number. The display will then be (Example: "B3 - B5"). The two for one option is available for six combinations. After setting the first combination, press button "J" to set the next combination. **NOTE:** Programming the same selection on both sides of the arrowhead (Example: B2 - B2) the selection will run twice.

Clearing 2 for 1 Option – From the service mode, press button 10 (blank display) **Press #1-#1-#C**, this will clear all combinations for this option. The display will show "_->_" to allow re-entering of new combinations or press button "K" to return to service.

EXITING SERVICE MODE

1. Press the mode switch on the board twice.
2. Deposit Money
3. Close the Door.
4. Push Coin Return.
5. Wait 5 Seconds.

7. PRICE SET MODE

The mode switch on the control board should be pressed twice to enter into the price set mode or once from the service mode. The display will then show (.) a decimal point. To set prices push the numbers (1-10) needed to change the display (Example 7 & 5 will display .75) Pressing the letter and then number (A-1) you will get two beeps indicating that selection price is set. To cancel the price display push letter "J".

To set prices with a product code which are available (00 to 99) press the letter "K" and push the desired code. Press the letter "J" and set the price. The product code & price showing on the display can now be entered to the program. Set all selections using "J" for pricing & "K" for product code. (**NOTE:** 500 mode is used to retrieve sales data of the product codes.)

8. PRICE CHECK MODE

This mode allows you to check prices and products codes set on each selection. Entering into the price check mode can be done by pressing the mode switch on the control board three times from operate (stand-by) or once from the prices set mode. Check each selection by pressing the letter and then the number. (**NOTE:** You can re-enter the service mode by pressing button "K" from the price check mode. This function saves time by not having to wait for the motor home check and the shelf check and "*****")

Discount Time Periods

Checking prices of an item in one of the four discount time periods may be accomplished by pressing the mode switch (control board) two times to access the price set mode. Press the letter "K". Press #9-#9-#9. The display will show "PRD1 00.00". Press the mode switch (control board) once to access price check mode. The display will show "CK". Press button "J" the display will show "CK D1". Any selection that has a cash discount set in time period A will show the discounted price when that letter/number

components

combination (i.e. A3, F3). Press J will step to CK D 2 for time period B etc. If no discount has been set, then the normal vend price will be displayed.

9. SELECTION PANEL

The selection panel (see figure 10) on the Snackshop 113 incorporates that use of a self enclosed membrane switch panel. This eliminates the need for individual switches and wiring. The membrane switch panel is housed in a stainless steel panel with individual buttons protecting the switch face. The casting front also houses the display lens. The display lens gives instructions to the customer for three conditions which might occur (make another selection, use correct change, or check selection price). The display lens also can carry any message which can be programmed. For example "Have a good day."

10. VEND MOTORS

The Snackshop 113 incorporates the use of a high RPM DC motor. Due to the new design, the vend motor may no longer be homed by hand. **DO NOT TRY TO TURN THE SPIRALS BY HAND. DAMAGE TO THE MOTOR WILL RESULT.** It is also important to check polarity before applying current to the motor. Two diodes and a capacitor are used to prevent circuit feedback and may have to be checked when trouble shooting motor problems.

11. LIGHTING SYSTEM:

There is only one fluorescent lamp in the Snackshop 113. The lamp is located on the top inside of the door which lights up the main product area. The starter is located on the hinge side of the lamp. The ballast and line filter is located on the top front left shelf support. (page 17, item 18)

12. MAIN PRODUCT SHELVES:

There are five or six main product shelves per machine. Each containing either five or ten selections. Each selection has its own motor mounted to the back of the shelf. Every shelf has its own harness and plug for connecting to the remainder of the circuit through the cabinet receptacle, located in the rear right of the cabinet. The motors are the same on either type shelf. It is now possible in the Snackshop 113 to exchange a five selection shelf with a ten selection shelf or visa versa. You also have the capability to gain 1/2 inch either up or down on any shelf. To do this the shelf should be removed and the cabinet back harness receptacle lowered or raised with the right & left shelf tracks.

NOTE: When exchanging the shelves, you will not need any parts, but you will have to reprogram the machines for prices and selections.

REMOVAL OF PRODUCT SHELF:

- Lift up and push the lock levers toward the back of cabinet. See figure 1, page 4.
- Pull the shelf to its loading position.
- Grasp shelf in front and rear center. Lift front of shelf up above horizontal and pull shelf forward while lifting.
- To install shelf, reverse above procedure.

13. DELIVERY BIN:

This is located below the display window on the door and is mechanically operated. The linkage on the outside end of the delivery bin may require occasional lubrication. Should the door become difficult to operate, place a small amount of grease on the arm tracks.

REMOVAL OF DELIVERY BIN:

- Remove the screws from the underside of the delivery bin . These screws fasten into the lower door brace and remove

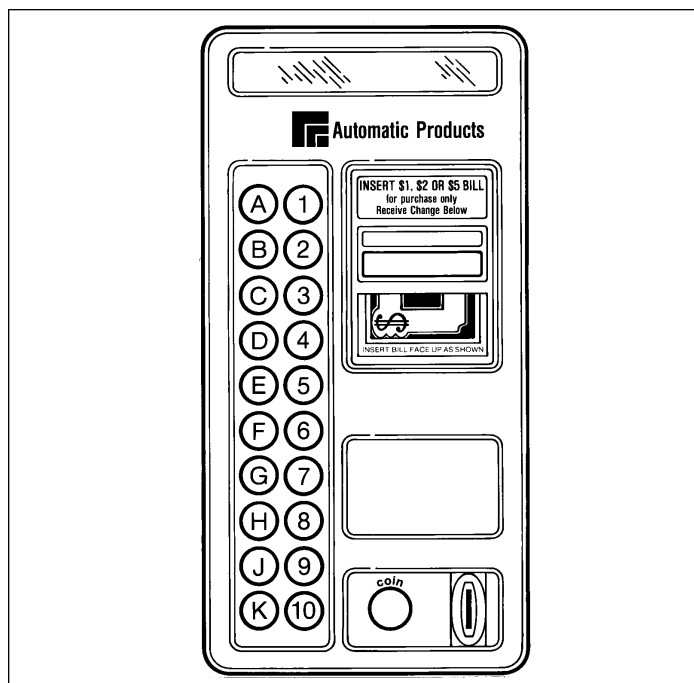

the two screws and brackets at the top of the delivery bin.

- Grasp delivery bin on both sides and lift up and pull back. Should bin be tight, rock it by lifting on one end, then the other.

REPLACEMENT OF DELIVERY BIN:

- Locate lip on front edge of delivery bin over lower edge of opening in door and behind trim. Press down along lip to make sure it is fully engaged between door and trim.
- Install the four screws and two brackets, to secure bin to door.

14. REMOVAL OF GUM AND MINT MOTOR AND/OR EJECTORS:

Disconnect the two wires going to the motor and remove the four screws holding it to the shelf. The components attached to the front base can also be replaced. These consist of the gum and mint shelf front (Price tabs and selection), gum and mint shelf front base, gum and mint display front stop (plastic) and the gum and mint ejector.

NOTE: Before replacing the gum and mint motor it would be helpful to tap the motor first with the screws. Assemble the four components together and mount them to the motor making sure that the head crank of the motor is inserted into the ejector. Replace the four screws and test vend that selection for proper operation.

15. REMOVAL OF GUM AND MINT SHELF:

Below the gum and mint shelf remove the two screws holding the gum and mint receptacle harness bracket (page 19, item 21). Loosen the other two screws on each end of the gum and mint pusher stop strap (page 29, item 20) and disengage it from the cabinet. Grasp the shelf and pull the shelf straight out. With the shelf out you can replace the gum and mint pusher (page 29, item 31) by removing the screw (page 29, item 21).

Reverse the procedure to replace the shelf. Pay special attention when you put the gum and mint pusher stop strap back on that all the gum and mint pushers have spring tension and are behind the strap.

16. CHILLED AIR MACHINE

When placing a chilled machine at a location Caution should be taken to keep adequate clearance in the rear and front bottom screens for proper circulation. The front vent screen assembly (page 37, item 25) should be removed and cleaned periodically for proper operation of the refrigeration system.

NOTE: The cold control setting (page 37, item 15) should be set on the #4 position.

17. REMOVAL OF COOLING UNIT:

Replacing a cooling unit can be done by removing the two screws from the Air Duct Support Bracket (page 35, item 3). Then, lift the air duct up and out of the cooling unit. Remove the two screws in the bottom of the cooling pan located to the right and next to the blower (page 37, item 23). The cooling unit can now be pulled straight out from the angle guides. Reverse the procedure to put the cooling unit back in the machine.

cleaning

The Snackshop 113 will do the best merchandising job for you if it is kept clean. The display window can be cleaned with any good glass cleaner. The exterior and interior surfaces should be cleaned with warm water and mild detergent. Rinse thoroughly and dry all surfaces.

The main product shelves can be best cleaned with the spirals and product spacers removed. Refer to page 4 for removal of spirals and page 5 for removal of the product spacer.

CAUTION:

Do not use any cleaners containing silicon as this could cause electrical failures.

Clean the acceptor on the changer frequently as accumulated dirt in this area can cause coins to hang or not be accepted. Follow recommended cleaning procedures as described by the manufacturer.

optional equipment

1. VENTILATING FAN: (Part #660441 - 120 Volts)
(Part #660441-1 - 240 Volts) Export

The ventilating fan keeps a steady flow of air moving through the vendor cabinet. Installation of the fan takes only a few minutes. All the vendors are wired with a fan plug on the junction box for easy installation.

2. BASE KITS: (Part # 660146-13)

Base kits are available to make the vendor compatible with other manufacturers.

3. GUM AND MINT:

Gum and Mint units are available as an option with Snackshop 113 vendors. For information pertaining to loading or servicing gum and mint unit, refer to this service manual for loading instructions and for service instructions.

4. SPECIAL SPIRALS:

Special candy spirals are available for use in the five (5) selection snack shelves. For the sake of identification, the back end of these spirals are colored RED and should never be used in the ten (10) selection candy shelves.

These spirals allow vending products that are too wide for the standard candy columns but may be too thin for the regular snack spirals. A product pusher and spacer should be used where required. Part numbers for these special spirals are as follows:

- 400139-1 12 space special spiral
- 400140-1 15 space special spiral
- 400141-1 18 space special spiral
- 400142-1 24 space special spiral
- 400143-1 30 space special spiral
- 400151-1 20 space special spiral

NOTE: The difference between the standard candy spiral and the special candy spiral used in the wide snack columns is in the overall length of the spiral. The special spiral is shorter than the standard candy spirals.

CAUTION: Do not attempt to use the special candy spirals in an ten (10) selection shelf.

5. SOUP DISPENSER: (Kit 750083)

A canned soup dispenser is available as an option for use in the five selection snack shelves. The dispenser is easy to install and holds up to nine cans in the unit

6. DOLLAR BILL VALIDATORS:

The validators take only a few minutes to install and may be purchased through the manufacturer of that unit. Mars has a 24 volt & 115 volt Validator available which will work in the machine provided that you use the right harness. The 115 volt harness can be ordered from Automatic Products under part #680475. The 24 volt harness can be ordered under part #680355. ARDAC validators need a kit supplied FROM ARDAC under part #48X600-4 to be added to the 113 machine. Coinco validators can also be used, which are the 115 volt model (BA30SA) or the 24 volt model (BA32SA).

7. DEBIT CARD READERS:

The 113 series machine will also have the option to add a debit card reader. The two choices available are the Mars and Debitek Systems.

8. CHILLED MACHINE:

The 113 machine may be ordered with a refrigeration unit which allows the inside of the cabinet to be cooled. **THE REFRIGERATION UNIT CANNOT BE ADDED TO A MACHINE AT A LATER DATE.**

9. DUAL SPIRAL SHELF:

Snack shelves can be set up to have dual spirals per selection on the shelf. The dual spirals will help vend specialty items better.

10. CONVERTIBLE SHELF:

The convertible shelf allows you to convert a snack shelf into a combination candy and snack shelf. The convertible shelf can be converted from two to ten candy selections. (Example: 4 candy selections & 3 snack).

11. 114 MASTER:

This unit can slave a 115 machine and is an optional model. The master machine must be a six shelf machine limited to 30, 35 or 40 selections. The gum and mint unit is optional. The master machine does not come in Euro-Styling.

12. MIS Printer (Part # 380310)

Printer Harness (Part # 680577)

DEX-UCS Harness (Part # 680509)

All three are needed for printer use (mode 501)

13. DOOR GUARD (Part #750176)

A kit is available to attach the guard to the door to help prevent someone prying the door open.

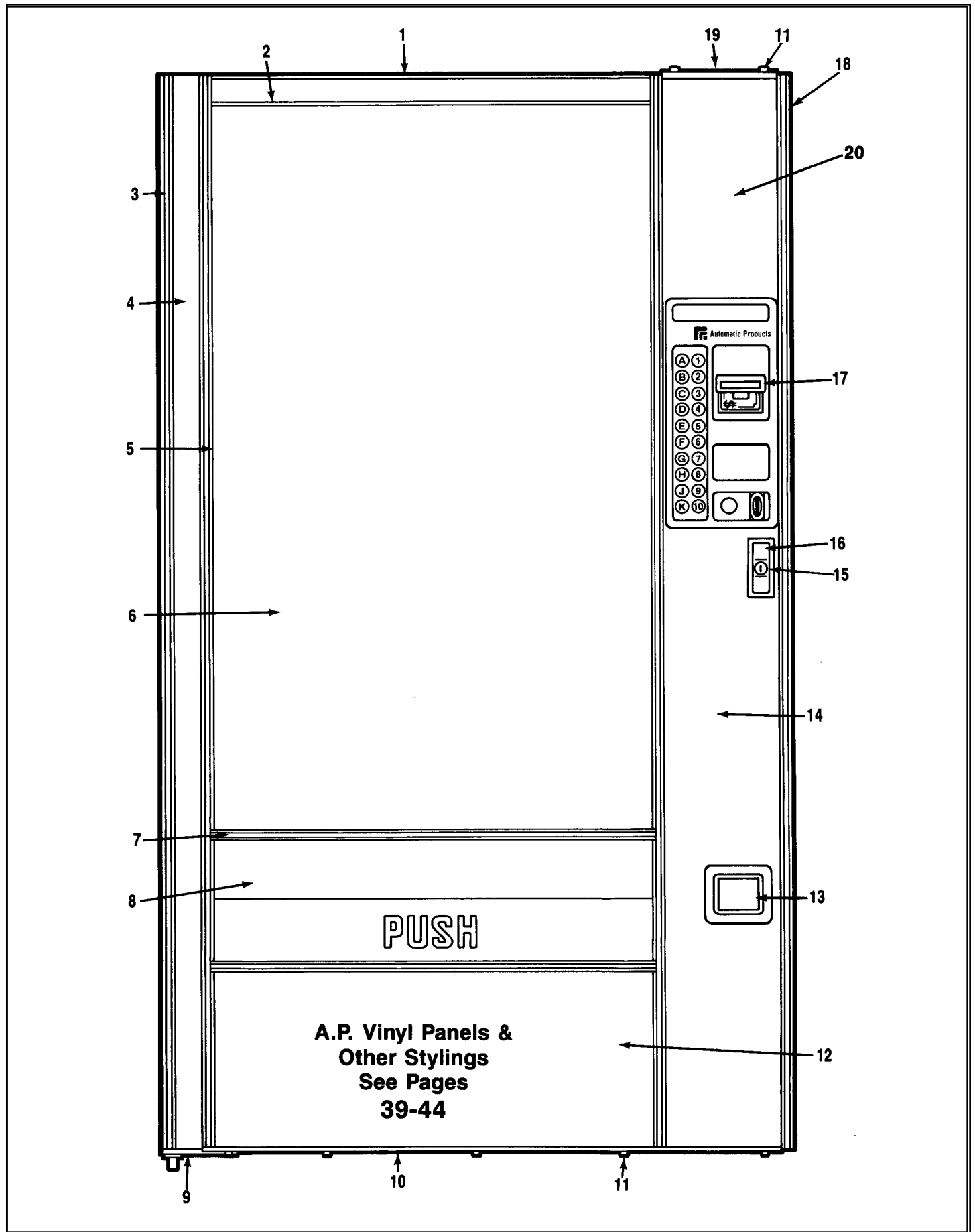

Item No.	Part No.	Description
1	340044-9	Top Trim Vantage.
2	201690-2	Top Trim Insert. True Grit Black.
	201690-15	Top Trim Insert. Dark Gray
3	340057-2	Trim Outside Vertical.Black. Right & Left Side.
4	202059-52	Panel, Left Side Vertical.Sterling Royce.
	202059-48	Panel, Left Side Vertical.White.
	202059-50	Panel, Left Side Vertical.Dove Gray.
	202059-8	Panel, Left Side Vertical. Painted.
5	340058-46	Trim Vertical.Window. Black, Right & Left Side.
6	750141	Front Window. (44 5/8 x 26 7/8 x 1/8). NOTE Replacement Glass Must Be Hard Tempered or Lexan Only.
7	340058-5	Trim Horizontal.Window. Black.
8	201356-1	Delivery Tray Panel. True Grit Black.
9	640154	Assembly, Lower Door Hinge Plate. Specify Color.
10	201678	Bottom Door Edging.
11	420186	Screw Pan Hd.#2 Drill Pt 6-20.
12	201692-1	Lower Horizontal Panel. Black.
	201692-56	Lower Horizontal Panel. Dark Gray.
	201356-43	Delivery Tray Panel. Dark Gray.
13	440296	Coin Cup Trim. Black.
	440296-1	Coin Cup Trim. Dark Brown.
	440296-2	Coin Cup Trim.Medium Gray.
	201156	Coin Cup Door.

Item No.	Part No.	Description
14	202061-42	Panel, Right Side Vertical.Lower. Sterling Royce
	202061-38	Panel, Right Side Vertical. Lower. White.
	202061-40	Panel, Right Side Vertical. Lower. Dove Gray.
	202061-7	Panel, Right Side Vertical. Lower. Painted.
15	420071	Ace Lock W/2 Keys.
	420071-1	Ace Lock W/1 Key.
	420071-2	Ace Lock W/O Key.
16	660319	Assembly Lock Handle W/Lock Arm & Nut.
	420146	Lock Handle Only.
17	660368	Assembly Complete. Selection Panel. See Page #21 for Itemized Parts.
18	600600	Door Only. Specify Color.
	600600-1	Door Only. European Style. Specify Color.
	600600-2	Door Only. With Validator Hole And Debit Card Use. Specify Color.
19	201678-6	Top Lock Door Edging.
20	202060-50	Panel, Right Side Vertical. Upper. White.
	202060-52	Panel, Right Side Vertical. Upper. Dove Gray.
	202060-8	Panel, Right Side Vertical. Upper. Painted.
	202060-54	Panel, Right Side Vertical.Upper. Sterling Royce.

door - inside front

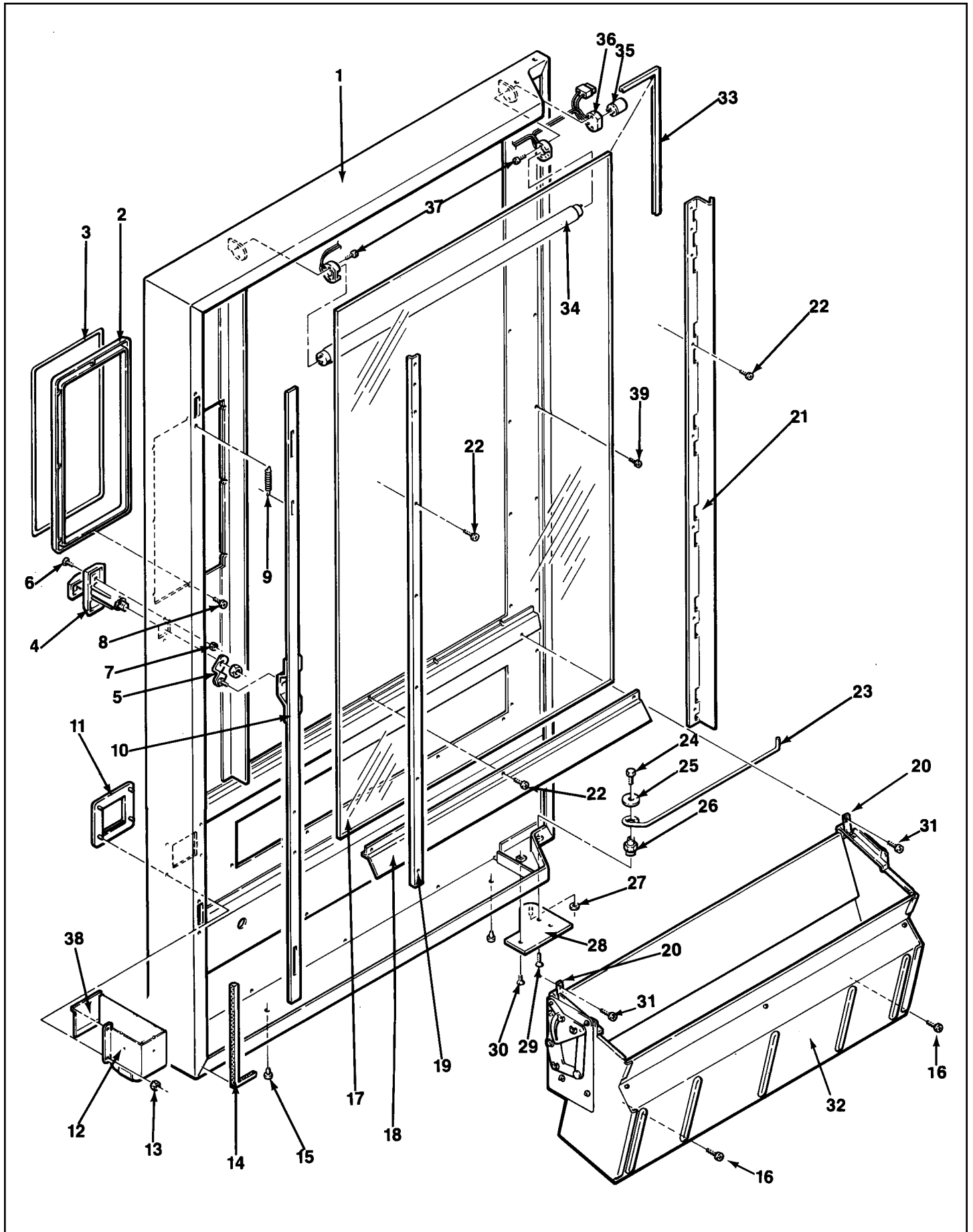

Item No.	Part No.	Description
1	600600	Door Only. Specify Color.
	600600-1	Door Only. European Style. Specify Color.
	600600-2	Door Only. With Validator Hole And Debit Card Use. Specify Color
2	750176	Kit, Door Guard Plate (Not Shown). Specify Color
	660444-1	Bezel Ring . Assembly w/Trim. Black.
	660444-2	Bezel Ring.Assembly w/Trim. Brown.
	660444-3	Bezel Ring.Assembly w/Trim. Gray.
	320060-1	Bezel Ring Only.
3	460499	Bezel Trim. Black.
	460499-1	Bezel Trim.Dark Brown.
	460499-2	Bezel Trim. Medium Gray.
4	660319	T-Handle & Lock Arm Assembly.
	420146	T-Handle Only w/Nut.
5	640131	T-Handle Lock Arm
6	118-10-8	Carriage Bolt #10-24.
7	404-10	Nut, Hex #10-24.
8	276-6R4	Screw Pan HD. Phil. Type 23. #6-32x1/4.
9	400112	Lock Bar Spring.
10	600432-2	Lock Bar Assembly.
11	440296	Coin Cup Trim. Black.
	440296-1	Coin Cup Trim. Dark Brown.
	440296-2	Coin Cup Trim. Medium Gray.
	201155	Coin Return Cup
12	660569	Assembly Coin Cup & Striker Export (not shown)
	600705	Coin Return Cup only Export
	202432	Striker, Door Switch Export
	300184	Shoulder Bushing Export
	276-8R6	Screw, Pan HD Self Tap (8-32x3/8)(2)
	400188	Spring, Striker Door Switch
	201894	Coin Cup Filler Plate.
13	18443	Nut 1/4. Self-Threading.
14	460041-1	Door Gasket Foam 1/4 x 1/4.
15	420040-9	Hole Plug.
16	276-8R6	Screw, Pan Hd.Phil. Type 23# 8-32x3/8.
17	750141	Front Window. (44-5/8 x 26-7/8 x 1/8) NOTE: Replacement Glass Must Be Hard Tempered or Lexan Only.
	460570	Decal."COOL - COOL" (not shown).

Item No.	Part No.	Description
18	201384	Bottom Window Clamp.
19	202118	Window Clamp. Lock Side.
20	200906	Bin Anchor Strap.
21	201381-3	Shield & Window Clamp. Pivot Side.
22	201-6R11	Screw RD. HD. Philips Type B #6 x 11/16.
	300206	Screw, Window
23	400095	Door Stop.
24	114-41-8	Screw, Hex HD. Cap 1/4 -20 x 1/2.
25	420010-10	Washer 1 1/8 OD.
26	300156	Door Stop Anchor.
27	420010-18	Washer, Brass (Door Adjustment).
28	640154	Lower Door Hinge Plate Assembly. Specify Color.
		Flat Head Socket Screw. 3/4 Lg.
29	420003	Flat Head Socket Screw. 1/2 Lg.
30	420003-1	Flat Head Socket Screw. 1/2 Lg.
31	217-8R10	Screw. Pan Head, Philips Type B #8 x 5/8.
32	660558	Delivery Bin.Assembly Complete. See Page 31 For Itemized Parts.
		Window Edging (Order Per Inches) 143 Total.
33	460436	Window Edging (Order Per Inches) 143 Total.
34	380022-5	Fluorescent Lamp F18T8/CWK24.
	380023-4	Starter FSII 240 volt
35	380023	Starter FS-25.
36	680512	Lamp Harness Assembly.
		Light Cord (Not Shown)
37	420062-1	Screw Round Head Slot Mach.#4-36 x 3/4.
38	201156	Coin Cup Door.
39	2016R7	Trim Screws. Screw Rd. Hd. Phillips Type A (6-18 x 3/8).
		Trim Screws. Screw Rd. Hd. Phillips Type A (6-18 x 3/8).
		Trim Screws. Screw Rd. Hd. Phillips Type A (6-18 x 3/8).
	2006R6	Trim Screws. Screw Rd. Hd. Phillips Type A (6-18 x 3/8).

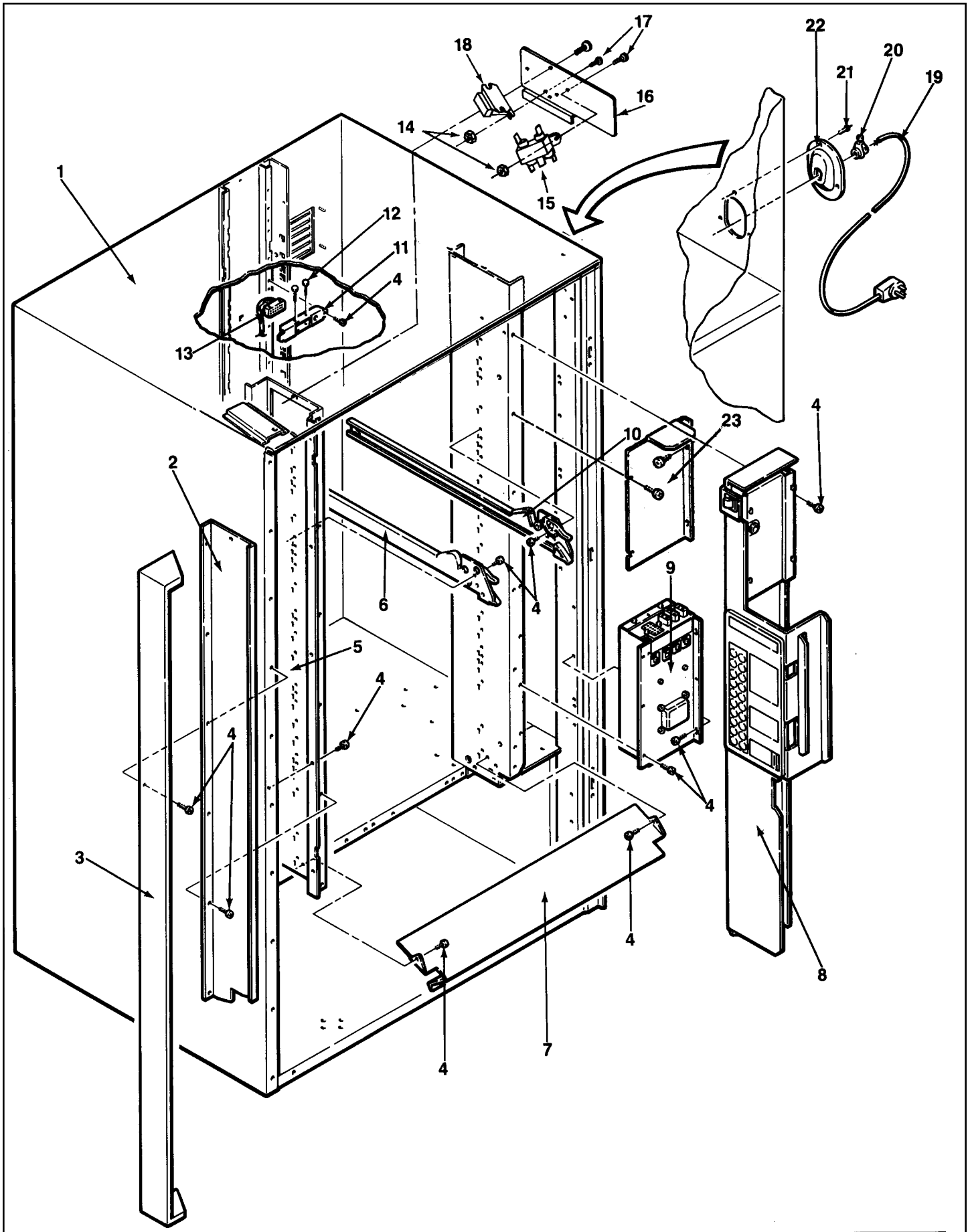

Item No.	Part No.	Description
1	750100-4	Cabinet Assembly Complete. With Legs. Specify Color. (113)
	750100-5	Cabinet Assembly Complete With Legs Specify Color. (114)
2	202119	Filler Plate. Left Front.
3	600310	Assembly, Cabinet to Door Filler. Specify Color.
4	276-8R6	Screw, Pan Hd.Self Tap. (8-32 x 3/8)
5	202120	Shelf Support. Left Front.
6	640177	Assembly, Cabinet Shelf Track. Left.
7	201386	Gum & Mint Filler Panel. (Use w/o G/M Shelf).
8		See Page #21 For Itemized Parts.
9		See Page #33 For Itemized Parts.
10	640177-1	Assembly, Cabinet Shelf Track. Right.
11	202177	Cabinet Receptacle Mounting Bracket Only.
12	420142-2	Drive Pin.
13	660442	Assembly Comp. Cabinet Back Harn.5 Shelves.
	660442-1	Assembly Comp. Cabinet Back Harn. 6 Shelves.
	660442-4	Harness Cabinet Back. 6 Shelves 114 only.

Item No.	Part No.	Description
14	404-6	Nut, Hex Hd. (6-32)
15	380303	Assembly, Line Filter.
16	660492	Assembly Complete. Light Ballast & Filter. 115 Volt
	660492-1	Assembly Complete. Light Ballast Filter. 220 Volt.
	660492-2	Assembly Complete. Light Ballast Filter. 240 Volt.
	202251	Cover Mounting Plate Only.
17	276-6R6	Screw, Pan Hd.(6-32 x 3/8).
18	680514	Ballast Only. 115 Volt.
	680513-1	Ballast Only. 220 Volt.
	680513	Ballast Only. 240 Volt.
19	360163	Power Inlet Cord Only.
	660506	Assy. Complete Power Cord w/plate.
	660505-1	Assy. Complete Power Cord w/plate.
20	380052-3	Strain Relief Bushing w/screw.
21	420078-1	Pop Rivet.
22	202270	Power Inlet Cord Plate.
23	202238	Validator Guard.
	680455-4	Ground Wire

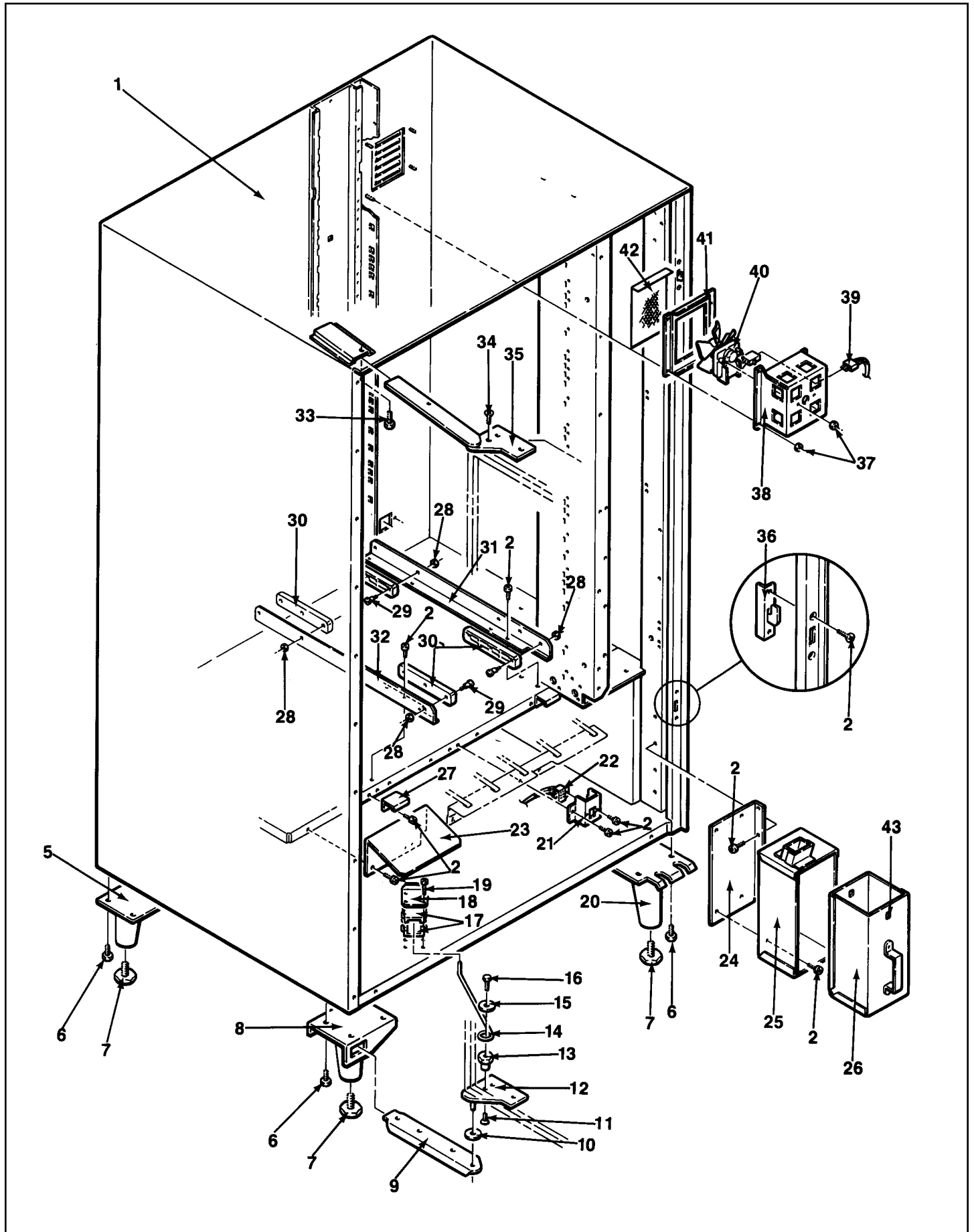

Item No.	Part No.	Description
1	750100-4	Cabinet Assembly Complete. With Legs. (113) Specify Color.
	750100-5	Assembly Complete. With Legs (113 M) Specify Color.
2	276-8R6	Screw, Pan Hd. Self-Tap (8-32 x 3/8).
5	600195	Leg Assembly Rear. Specify Color.
6	420187	Screw, Hex Hd. Mach.(5/16 - 18 x 3/4).
7	300103	Leg Leveler.
	660599	Leg Leveler Bolt "Multisnack".
8	600302	Leg Assembly Front. Pivot Side. Specify Color.
9	202088	Lower Hinge Support. Specify Color.
10	420010-18	Washer (1-1/4).
11	420003	Screw, Flat Hd.(1/4 - 20 x 3/4).
12	640154	Assembly, Lower Door Plate. Specify Color.
13	300156	Door Stop Anchor.
14	400095	Door Stop.
15	420010-10	Washer.
16	114-41-8	Screw Hex Hd.Mach.(1/4 - 20 x 1/2)
17	440204	Door Stop Friction Pad.
18	201042	Door Stop Plate.
19	277-10R16	Screw Pan Hd.Self Tap. (10-32 x 1).
20	600197	Assembly, Leg Front.Lock Side. Specify Color.
21	201415	Gum & Mint Mounting Bracket Plug.
22	380230	Gum & Mint Receptacle Plug Only.
23	202065	Plate, Gum & Mint Deflector.
24	202124	Cash Box Support.

Item No.	Part No.	Description
25	600648	Assembly Cash Box Mounting.
26	600179-1	Cash Box.
27	201453	Gum & Mint Tray Catch.
28	437-41	Nut, Keps (1/4 - 28).
29	300137	Screw, Shelf Roller.
30	440278	Gum & Mint Tray Slide.
31	660439	Assembly Complete. Gum & Mint Support. Right Side.
	202064	Gum & Mint Support.Right Side.
32	202064-1	Gum & Mint Support.Left Side.
	660439-1	Assy. Complete. G&M Support. Left Side.
33	164-51-7	Screw Hex Hd.Sems (5/16 - 18 x 3/8).
34	420003-1	Screw Flat Hd.(1/4 - 20 x 1/2).
35	640107-1	Assembly, Upper Hinge. Specify Color.
36	600433	Assembly, Door Lock Catch.
37	404-4	Hex Nut (8-32).
38	202072	Fan Housing.
39	680456	Harness, Fan.
40	360122-2	Fan Motor. 115 Volt.
	660441	Kit, Fan Add-On.115 Volt.
	660441-1	Kit, Fan Add-On. 240 Volt.
	360122-3	Fan Motor. 230 Volt.
41	202070	Screen Bracket.
	202235	Cover Plate (Use w/o Fan).
42	202071	Screen.
43	750097	Lock and Cam door Cash Box.w/2 Keys. Specify Number.
	420020	Lock w/1 key. Specify Number.
	420069	Cam Cash Box Locking only.

swing out – panel assembly

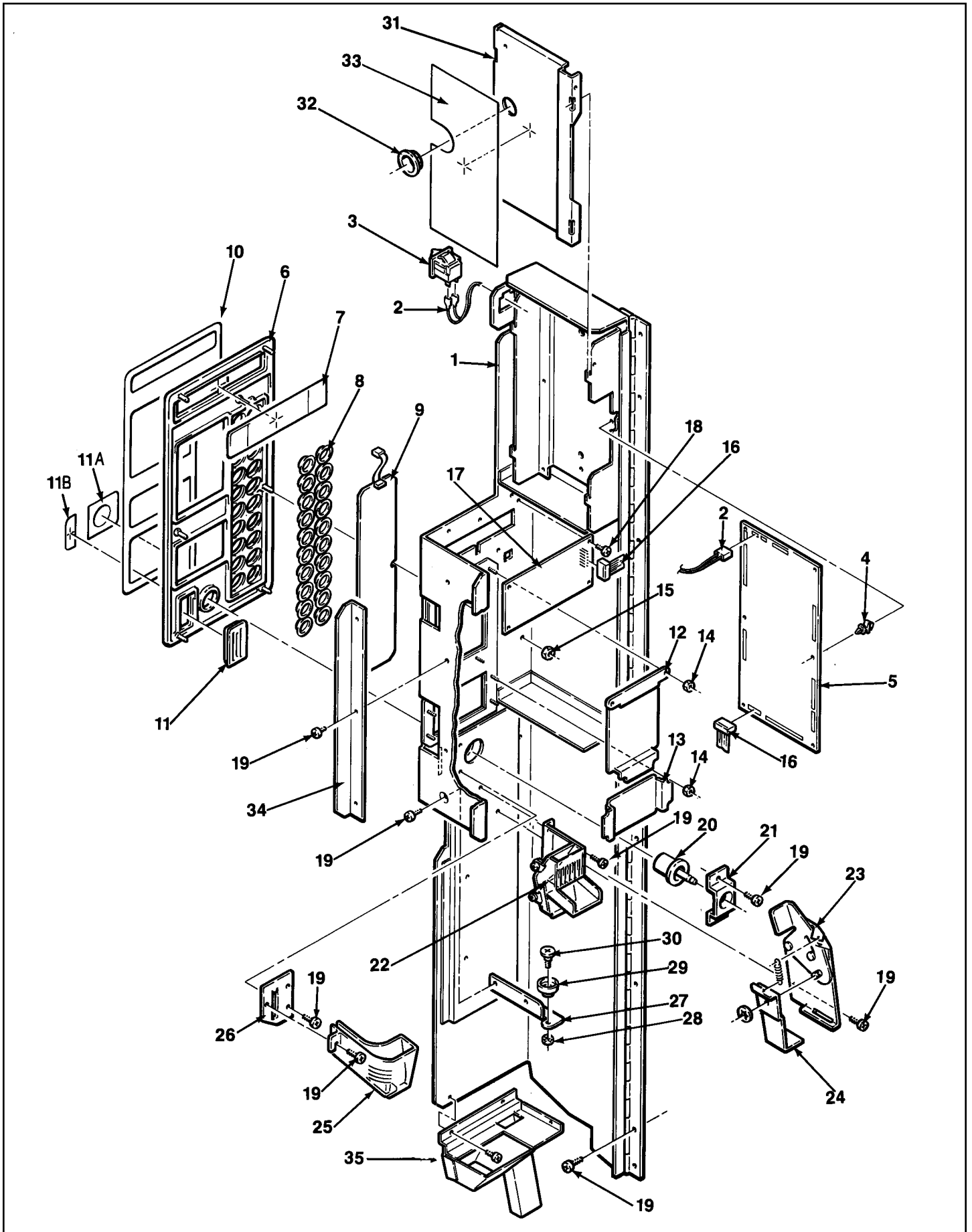

Item No.	Part No.	Description
1	660446 600614	Assembly Complete, Swing Out Panel. Panel Only.
2	680310	Door Operate Switch Harness.
3	380258	Door Operate Switch.
4	420095	P.C. Board Stand Off.
5	360165 380308	Control Board. Battery (Not Shown)
6	660368 660368-1 660368-2 320057-1	Front Bezel, Assembly Complete. Black. Front Bezel, Assembly Complete. Brown. Front Bezel, Assembly Complete. Gray. Front Bezel Only.
7	440310	Display Lens.
8	440304 460415 460415-1 460415-2	Selector Button. Quantity 20. Decal, Selector Button Background, Black. Decal, Selector Button Background, Dark Brown. Decal, Selector Button Background, Medium Gray.
9	660366	Selector Switch & Plate Assembly.
10	460414 460414-1 460414-2 460414-3	Bezel Background. Black. Bezel Background. Multicard. Bezel Background. Dark Brown. Bezel Background. Medium Gray.
11	440309 440309-1	Coin Entrance. Coin Entrance (Use W/Debitek Only).
11A	460416 460416-1 460416-2	Decal, Coin Return Button. Black. Decal, Coin Return. Dark Brown. Decal, Coin Return. Medium Gray.
11B	460417 460417-1 460417-2	Decal, Right Side Insert Filler. Black. Decal, Right Side Insert Filler. Dark Brown. Decal, Right Side Insert Filler. Medium Gray.
12	660370 460424 660370-1 460424-1 660370-2 460424-2 460424-4 460636	Assembly, Validator Filler. Black. Validator Decal Only. Black. Assembly, Validator Filler. Dark Brown. Validator Decal Only. Dark Brown. Assembly, Validator Filler. Medium Gray. Validator Decal Only. Medium Gray. Validator Decal. Dark Gray. Validator Decal French

Item No.	Part No.	Description
	202708	Adaptor Bracket CBV (Not Shown).
13	660371 460425 660371-1 460425-1 460425-2 660371-2 460425-3	Debit Card Filler Assembly. Black. Debit Card Decal Only. Black. Debit Card Filler Assembly. Dark Brown. Debit Card Decal (Use w/Debitek Only). Debit Card Decal Only. Dark Brown. Debit Card Filler Assembly. Medium Gray. Debit Card Decal Only. Medium Gray.
	460637	Debit Card Decal Only French
15	18443	Hex Nut 1/4 Self Threading.
16	680457	Connector Ribbon - Control Board.
17	360166 360166-1 460533	Display Board W/O Optics. Display Board W/Optics. Display Board Pad.
18	200-6R6	Screw, Rd. Hd. Type AB #6.
19	276-8R6	Screw, Pan.Had. Phil. Type 23 #8-32 x 3/8.
20	440289 440289-2 440289-3	Coin Return Button. Gray. Coin Return Button (Use w/Debitek Only). Coin Return Button. Black.
21	201660	Coin Return Support Bracket.
22	660488	Coin Chute Assembly. Plastic.
23	660367 640152 751-25 400034	Coin Return, Assembly Complete. Coin Return Bracket Only. Retaining Ring (1/4). Spring, Indexing Lever.
24	201703	Coin Return Link.
25	440311	Coin Chute.
26	201712	Coin Chute Support Bracket.
27	660445 202121	Panel Latch, Assembly Complete. Latch, Bracket Only.
28	437-41	Nut 1/4-28 Keps.
29	440362	Shelf Roller.
30	300203	Shelf Roller Screw.
31	660448 660448-3 660448-2 202175	Control Board Cover Assembly. Control Board Cover Assembly England Control Board Cover Assembly French Cover Only.
32	420040-3	Hole Snap Bushing.
33	460514 460539 460657 460575	Instructions, Control Board. Instructions, Control Board. French. Instructions, Control Board England Instructions, Control Board Export
34	202136	Panel Stop. (111,112 Only).
35	750182	Assembly Complete. Coin Chute. (2 pcs.)

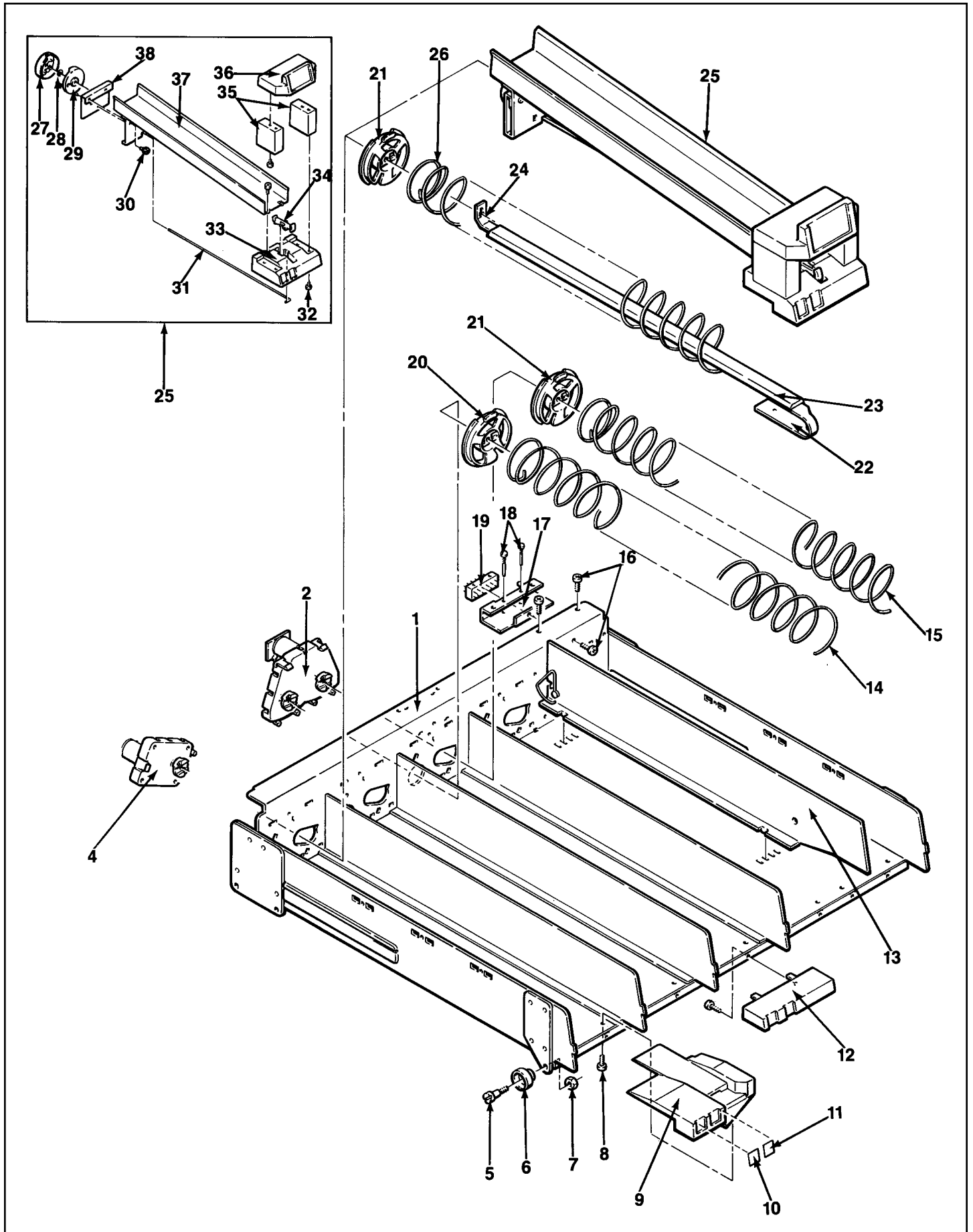

Item No.	Part No.	Description
1	750121-3 750162 600240-3	Assembly Complete Snack Shelf w/o Spirals Assembly Complete. Dual Snack Shelf w/o Spirals. Snack Shelf Only.
2	750159 360169	Kit, Dual Spiral Add-On. Dual Spiral Motor Only. White.
4	360138	Vend Motor Complete. White.
5	300203	Shelf Roller Screw.
6	440362	Shelf Roller.
7	437-41	Nut, Keps (1/4 x 28).
8	305-8R6	Screw Pan Head. Phillips. Plastite (8-16 x 3/8).
9	440285	Price and Selection Tab Holder.
10	460346	Item Tabs.
11	460347 460602	Price Tabs. Assorted 25¢ - \$1.50. Price Tabs. Assorted \$3.10 - \$4.05 (See Candy Shelf Additional Price Sheets Next Page)
	460529	Price Tabs. French
	460540	Price, Tabs. Mexico
	460561	Price Tabs. Spanish
	460727	Price Tabs. Italian
	460644	Price Tabs. English
12	440367	Dual Spiral Pastry Shelf. Front Only.
13	640101 202770	Spacer, Snack Shelf. Snack Shelf Extra Extension (Not Shown).
14	400169-1 400170-1 400171-1 400179-1 400178-1	Dual Spiral Only. Left Hand.10 Space. Chrome. Dual Spiral Only. Left Hand.12 Space. Chrome. Dual Spiral Only. Left Hand.15 Space. Chrome. Dual Spiral Only. Left Hand. 9 Space Chrome. Dual Spiral Only. Left Hand. 7 Space Chrome.
15	400168-1 400120-1 400121-1 400166-1 400164-1	Dual Spiral Only. Right Hand. 10 Space. Chrome. Dual Spiral Only. Right Hand.12 Space. Chrome. Dual Spiral Only. Right Hand.15 Space. Chrome. Dual Spiral Only. Right Hand. 9 Space. Chrome. Dual Spiral Only. Right Hand. 7 Space. Chrome.
16	276-8R6	Screw, Pan Head.Self-Tap. (8-32 x 3/8).

Item No.	Part No.	Description
17	600601	Shelf Plug,Bracket Only.
18	420142-2	Pin Drive.
19	660435-2 680446	Assembly Complete. Harness and Plug Bracket. Harness, Pastry Shelf Only.
20	440366	Spiral Retainer. Left Hand. Gray.
21	440287	Spiral Retainer. White.
22	201534	Front Support Only.
23	660330-2 660330-4 660191-8 440148-1 600723	Assembly Product Rail. For Use W/Pastry. Product Rail for Use W12 Oz. Cans. Assembly Product Rail for Use With Kit Kat. Plastic Product Rail Only. Metal Rail R.R.Battery.
24	200913	Rear Support Bracket Only. Use W/Pastry Spiral.
25	750083	Kit, Can Dispenser.
26	400127-1 400128-1 400129-1 400136-1 400137-1 400153-1 400162-1 400163-1 14000002	Snack Spiral. 10 Space, Chrome. Snack Spiral. 12 Space, Chrome. Snack Spiral. 15 Space, Chrome. Snack Spiral. 30 Space, Chrome. Snack Spiral. 40 Space, Chrome. Snack Spiral. 7 Space, Chrome. Snack Spiral. 6 Space, Chrome. Snack Spiral. 18 Space, Chrome. Snack Spiral. 5 Space, Chrome.
27	440201	Drive Cam.Rear.
28	751-31	Retaining Ring (#31).
29	440200	Drive Cam. Front.
30	300184 277-10R8	Shoulder Bushing. Screw Type 23 (#10-32 x 1/2).
31	400094	Actuator Wire.
32	305-8R6	Screw Pan Hd.Phillips Plastite (8-16 x 3/8).
33	440196	Price And Selection Trim.
34	440199	Stop Lever.
35	440198	Leg, Top Can Guide & Sign Trim.
36	440197	Top, Can Guide & Sign Trim.
37	600308	Can Dispenser. Trough Only.
38	640109	Cam., Mtg. Bracket & Spring Assembly.

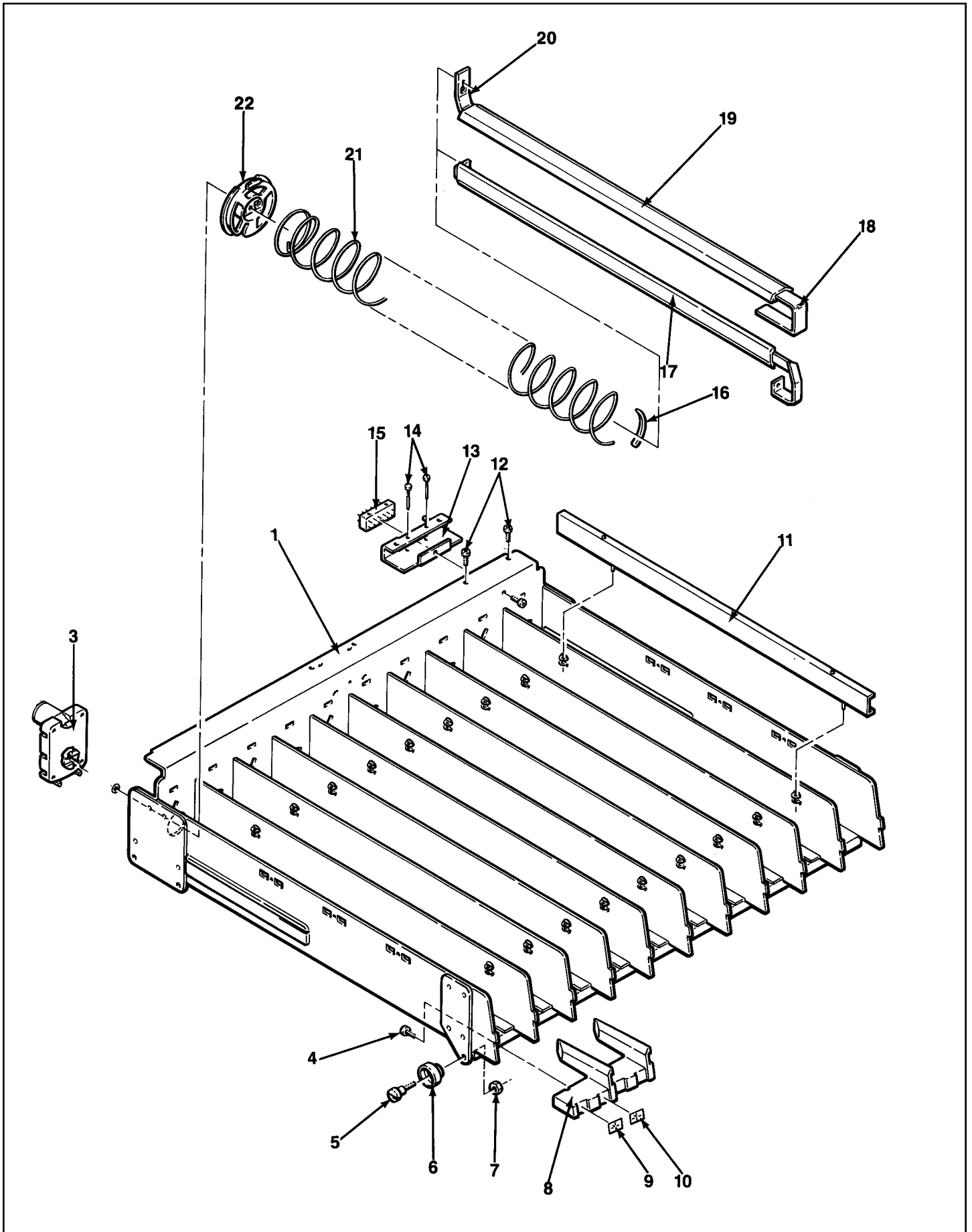

Item No.	Part No.	Description
1	750122-3	Assembly Complete. Candy Shelf w/o Coils.
	750122-6	Assembly Complete. Candy Shelf w/o Coils.
	600239-2	Candy Shelf Only.
	600662	Candy Shelf Only. 9 Selections.
3	360138	Vend Motor Complete. White.
	360155	Vend Motor Complete. Half-Cycle. Brown & White
	750135	Kit, Half-cycle Add-on.
4	305-8R6	Screw, Pan Hd.Plastite (#8 x 3/8).
5	300203	Screw, Shelf Roller.
6	440362	Shelf Roller.
7	437-41	Nut, Keps (1/4 x 28).
8	440262	Price and Selection Tab Holder. Off-set.
	340063	Shelf Front Trim. 9 Selections. (Not Shown)
9	460346	Item Tabs.
10	460347	Price Tabs. Assorted 25¢ - \$1.50
	460602	Price Tabs. Assorted \$3.10 - \$4.05
	460347-1	Price Tabs. All 30¢ - 35¢
	460347-2	Price Tabs. All 40¢ - 45¢
	460347-3	Price Tabs. All 50¢ - 55¢
	460347-4	Price Tabs. All 60¢ - 65¢
	460347-5	Price Tabs. All 70¢ - 75¢
	460347-6	Price Tabs. All 80¢ - 85¢
	460347-7	Price Tabs. All 90¢ - 95¢
	460347-8	Price Tabs. All \$1.00 - \$1.05.
	460347-9	Price Tabs. All \$1.10 - \$1.15.
	460347-10	Price Tabs. All \$1.20 - \$1.25.
	460347-11	Price Tabs. All \$1.30 - \$1.35.
	460347-12	Price Tabs. All \$1.40 - \$1.45.
	460347-13	Price Tabs. All \$1.50 - \$1.55.
	460347-14	Price Tabs. All \$1.60 - \$1.65.
	460347-15	Price Tabs. All \$1.70 - \$1.75.
	460347-16	Price Tabs. All \$1.80 - \$1.85.
	460347-17	Price Tabs. All \$1.90 - \$1.95.
	460347-18	Price Tabs. All \$2.00 - \$2.05.
	460347-19	Price Tabs. All \$2.10 - \$2.15.
	460347-20	Price Tabs. All \$2.20 - \$2.25.
	460347-21	Price Tabs. All \$2.30 - \$2.35.
	460347-22	Price Tabs. All \$2.40 - \$2.45.
	460347-23	Price Tabs. All \$2.50 - \$2.55.
	460347-24	Price Tabs. All \$2.60 - \$2.65.
	460347-25	Price Tabs. All \$2.70 - \$2.75.
	460347-26	Price Tabs. All \$2.80 - \$2.85.
	460347-27	Price Tabs. All \$2.90 - \$2.95.
	460347-28	Price Tabs. All \$3.00 - \$3.05.
	460740	Price Tabs. (75¢ - \$1.25)
	460529	Price Tabs. French.
	460540	Price Tabs. Mexico.
	460561	Price Tabs. Spanish.
	460644	Price Tabs. English.
	460727	Price Tabs. Italian.

Item No.	Part No.	Description
11	660178	Assembly, Candy Spacer.
12	276-8R6	Screw Pan Hd.Self Tap (8-32 x 3/8).
13	600601	Shelf Plug, Bracket Only.
14	420142-2	Drive Pin.
15	660435-1	Harness & Bracket Complete.
	680445-1	Harness, Candy Shelf Only.
16	440141-1	Candy Product Pusher.
17	660296	Small Product Guide.
	660503	Product Guide Assembly For Use w/ Half Cycle Motor.
18	201258	Front Support Only.
19	660191	Assembly Product Rail.
	440148-1	For Use w/Candy Spiral.
	600618	Plastic Product Rail Only.
	660191-8	Product Rail For Use W/ 12 Oz.Cans.
	660191-8	Product Rail for Kit Kat.
20	200913	Rear Support Bracket Only.
21	400120-1	12 Space Candy Spiral, Chrome.
	400121-1	15 Space Candy Spiral, Chrome.
	400122-1	18 Space Candy Spiral, Chrome.
	400123-1	24 Space Candy Spiral, Chrome.
	400135-1	30 Space Candy Spiral, Chrome.
	400138-1	40 Space Candy Spiral, Chrome.
	400164-1	7 Space Candy Spiral, Chrome.
	400166-1	9 Space Candy Spiral, Chrome.
	400167-1	6 Space Candy Spiral, Chrome.
	400168-1	10 Space Candy Spiral, Chrome.
22	440287	Spiral Lock.

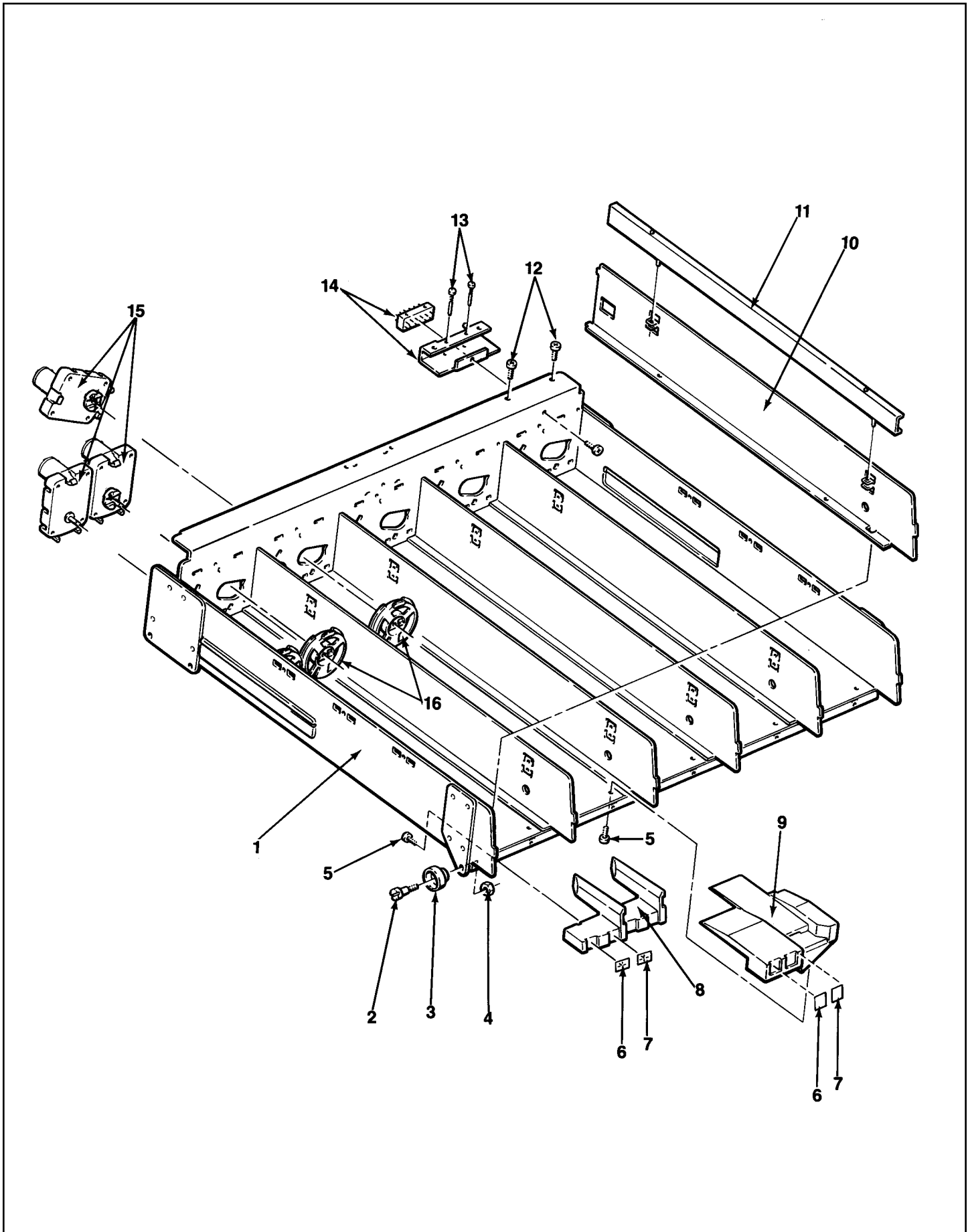

Item No.	Part No.	Description
1	750147-6	Assembly Complete. Convertible Shelf. (5 Snack Selections).W/o spirals.
	750147-7	Assembly Complete. Convertible Shelf. (4 Snack Selections and 2 Candy).W/o spirals.
	750147-8	Assembly Complete. Convertible Shelf. (3 Snack Selections and 4 Candy).W/o spirals.
	750147-9	Assembly Complete. Convertible Shelf. (2 Snack Selections and 6 Candy).W/o spirals.
	750147-10	Assembly Complete. Convertible Shelf. (1 Snack Selection and 8 Candy).W/o spirals.
	750147-11	Assembly Complete. Convertible Shelf. (10 Candy Selections).
	750162	Assembly Complete. Dual Spiral Snack Shelf. W/o Spirals.
	750159	Kit, Dual Spiral Add-On.W/o spirals (Use per selection).
	600240-3	Convertible Snack Shelf Only.
2	300203	Screw, Shelf Roller.
3	440362	Roller, Shelf.
4	437-41	Nut, Keps (1/4 x 28).
5	305-8R6	Screw Pan Hd.Phillips. Plastite (8-16 x 3/8).
6	460346	Item Tabs.
7	460347	Price Tabs. Assorted 25¢ - \$1.50.
	460602	Price Tabs Assorted \$3.10 - \$4.05
	460347-1	Price Tabs. All 30¢ - 35¢.
	460347-2	Price Tabs. All 40¢ - 45¢.
	460347-3	Price Tabs. All 50¢ - 55¢.
	460347-4	Price Tabs. All 60¢ - 65¢.
	460347-5	Price Tabs. All 70¢ - 75¢.
	460347-6	Price Tabs. All 80¢ - 85¢.
	460347-7	Price Tabs. All 90¢ - 95¢.
	460347-8	Price Tabs. All \$1.00 - \$1.05.
	460347-9	Price Tabs. All \$1.10 - \$1.15.
	460347-10	Price Tabs. All \$1.20 - \$1.25.
	460347-11	Price Tabs. All \$1.30 - \$1.35.

Item No.	Part No.	Description
	460347-12	Price Tabs. All \$1.40 - \$1.45.
	460347-13	Price Tabs. All \$1.50 - \$1.55.
	460347-14	Price Tabs. All \$1.60 - \$1.65.
	460347-15	Price Tabs. All \$1.70 - \$1.75.
	460347-16	Price Tabs. All \$1.80 - \$1.85.
	460347-17	Price Tabs. All \$1.90 - \$1.95.
	460347-18	Price Tabs. All \$2.00 - \$2.05.
	460347-19	Price Tabs. All \$2.10 - \$2.15.
	460347-20	Price Tabs. All \$2.20 - \$2.25.
	460347-21	Price Tabs. All \$2.30 - \$2.35.
	460347-22	Price Tabs. All \$2.40 - \$2.45.
	460347-23	Price Tabs. All \$2.50 - \$2.55.
	460347-24	Price Tabs. All \$2.60 - \$2.65.
	460347-25	Price Tabs. All \$2.70 - \$2.75.
	460347-26	Price Tabs. All \$2.80 - \$2.85.
	460347-27	Price Tabs. All \$2.90 - \$2.95.
	460347-28	Price Tabs. All \$3.00 - \$3.05.
	460740	Price Tabs. (75¢ - \$1.25)
	460529	Price Tabs. French.
	460540	Price Tabs. Mexico.
	460561	Price Tabs. Spanish.
	460644	Price Tabs. English.
	460727	Price Tabs. Italian.
8	440262	Price and Selection Tab Holder, Offset Candy. (Please see Page 25, Item #21 for Candy Spirals).
9	440285	Price and Selection Tab Holder, Snack.(Please see Page 23, Item #26 for Snack Spirals).
10	200753-2	Shelf Divider. Candy.
11	660178	Assembly Candy Spacer.
12	276-8R6	Screw Pan Hd.Self-Tap (8-32 x 3/8).
13	420142-2	Pin, Shelf Plug.
14	660435	Harness, Candy Shelf with Plug Bracket.
	600601	Shelf Plug Bracket Only.
15	360138	Vend Motor Complete. White.
	750150	Kit, Convertible Shelf. 2 Selection Add-On.
16	440287	Spiral Lock.

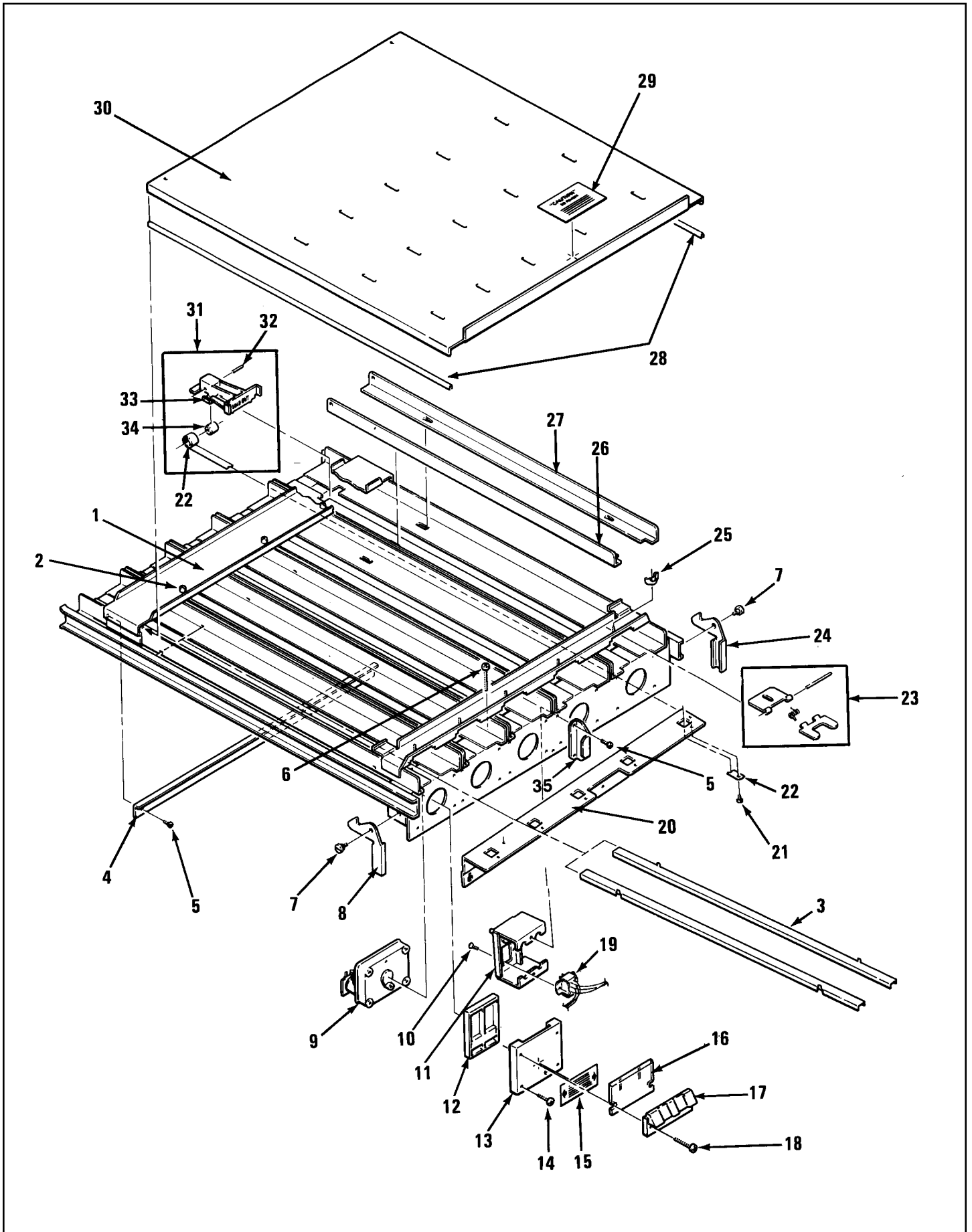

Item No.	Part No.	Description
1	660316 660316-3	Assembly Complete. Gum & Mint Shelf. Assembly Complete. Gum & Mint Shelf, Export Only.
	600420 600460-1	Gum and Mint Shelf Only. Gum and Mint Shelf Only. Export.
	750165 750165-9	Kit, Gum and Mint Add-On. Kit, Assembly Complete Gum and Mint Shelf Australia.Add-on.
2	420040-9	Snap Bushing and Hole Plug.
3	201412	Thin Mint Adapter (2 per selection).
4	201458 201458-2	Gum and Mint Rear Pusher Stop. Gum and Mint Rear Pusher Stop, Export Only.
5	276-8R6	Screw, Pan Hd.Self-Tap Phillips (8-32 x 3/8).
6	217-8R22	Screw, Pan Hd.Phillips Type AB (1-3/8).
7	300184 277-10R8	Shoulder Bushing. Screw Type 23 (#10-32 x 1/2).
8	201454-1	Gum and Mint Shelf Latch. Left Side.
9	360105	Gum and Mint Motor. White
10	420089	Screw,100° Flat Hd. (6-32 x 1/2).
11	600427	Gum and Mint Plug Mounting Bracket.
12	440267	Ejector, Gum and Mint.
13	440266	Gum and Mint Shelf Front Base.
14	305-7R16	Screw, Pan Hd.Plastite (#7 x 1).
15	460352	Decal, Gum and Mint Shelf Latch.
16	440270	Display Stop. Gum and Mint Column Front.
17	440273	Gum and Mint Shelf Front.

Item No.	Part No.	Description
18	305-7R22	Screw, Pan Hd.Plastite (#7 x 1-3/8).
19	680305 660340 380229 660340-1	Harness, Gum and Mint Shelf. Harness, Gum and Mint Shelf. W/BRKT Gum and Mint Shelf Plug Only. Harness G & M Shelf & Bracket, Export Only.
	680322	Harness Only. Export.
20	201414 201527	Strap, Gum and Mint Pusher Stop. G & M Pusher Stop Strap, Export Only.
21	262-6R5	Screw, Flat Hd. Phil. Type 23 (6-32 x 5/16).
22	400106	Spring, Gum and Mint Pusher Return.
23	660314 660314-1	Assembly, Complete Gum and Mint Display. Hinge. Assembly, Complete Gum and Mint Display Hinge, Export Only.
24	201454	Gum and Mint Shelf Latch. Right Side.
25	420023	Wing Nut (8-32).
26	201411-1	Column Spacer, Left.
27	201411	Column Spacer, Right.
28	420296	Shelf Grommet. (NGS #1 22).
29	460351	Decal, Caution. Gum and Mint Shelf.
30	201409 201530	Cover,Gum and Mint Shelf. Cover Gum and Mint Shelf, Export Only.
31	660313	Assembly, Complete. Gum and Mint Pusher and Spring.
32	801G125-12	Roll Pin (1/8 x 3/4).
33	440265	Pusher Only.
34	440274	Roller, Gum and Mint Pusher.
35	201691	Shelf Closer.

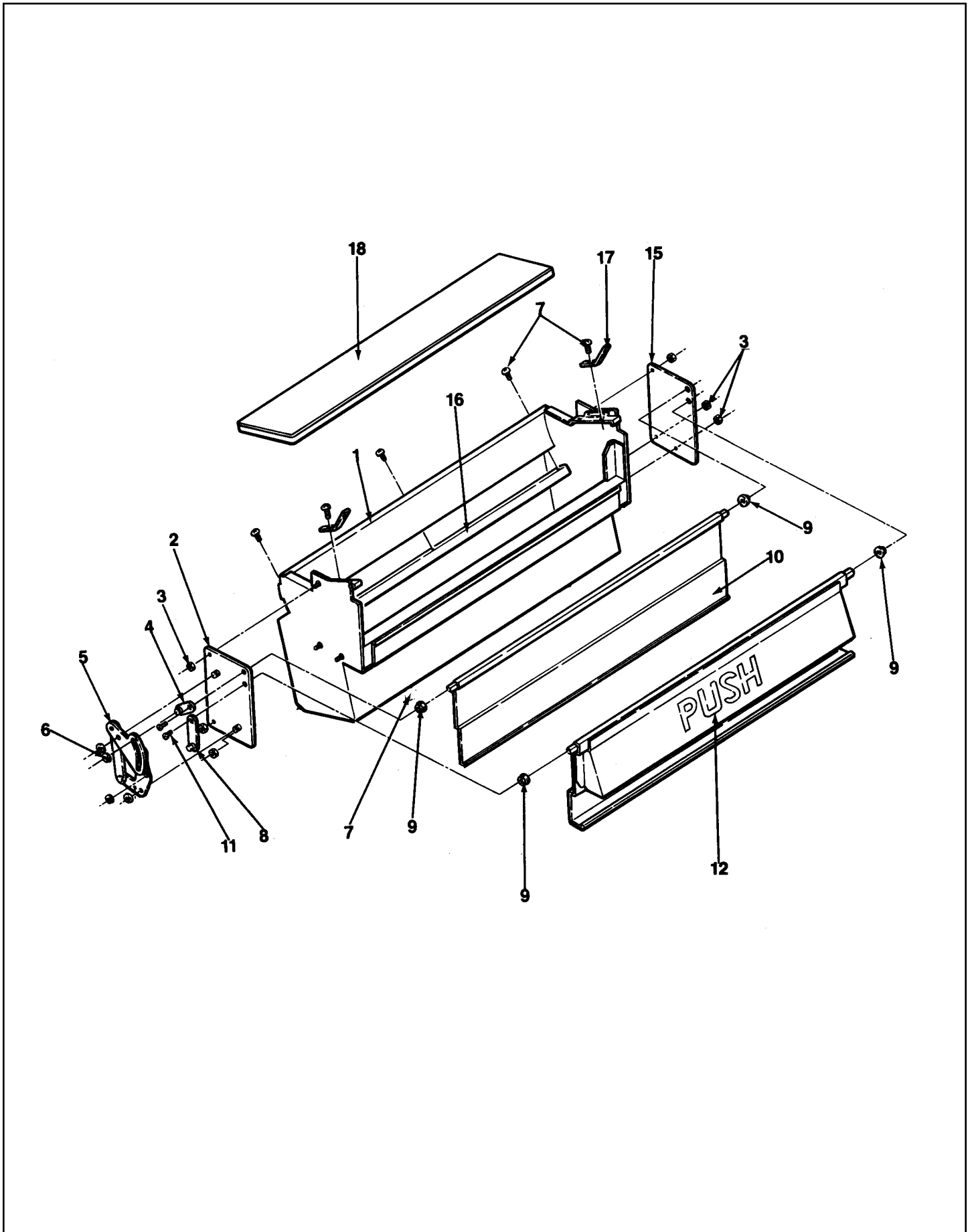

Item No.	Part No.	Description
1	660558	Delivery Bin Assembly. Complete. Black.
	660558-2	Delivery Bin Assembly. Complete. Gray.
	600704	Delivery Bin.
2	640187-1	Arm Mounting Bracket.
3	438-8	Nut, Keps. No. 8-32.
4	640098	Inner Door Bin Arm.
5	640100-1	Bin Door Drive Assembly.
6	751-37	Retaining Ring No. 37.
7	750183	Kit, Lower Bracket Repair.
8	640097	Door Drive Arm.

Item No.	Part No.	Description
9	440129	Door Bearing.
	420282	Bin Door Washer (Not Shown).
10	200763	Inner Door.
	200763-5	Inner Door Steel
11	276-846	Screw, Pan Hd., Self Tap. (8-32 x 3/8)
12	440373	Door, Delivery Bin.Black.
	440373-2	Door, Delivery Bin.Gray.
15	202285	Arm Mounting Bracket (Lock Side).
16	200902	Baffle, Rear Delivery Bin.
17	200906	Delivery Bin Anchor Strap.
18	420315	Delivery Bin Pad Assembly for Can Dispenser.

main junction box

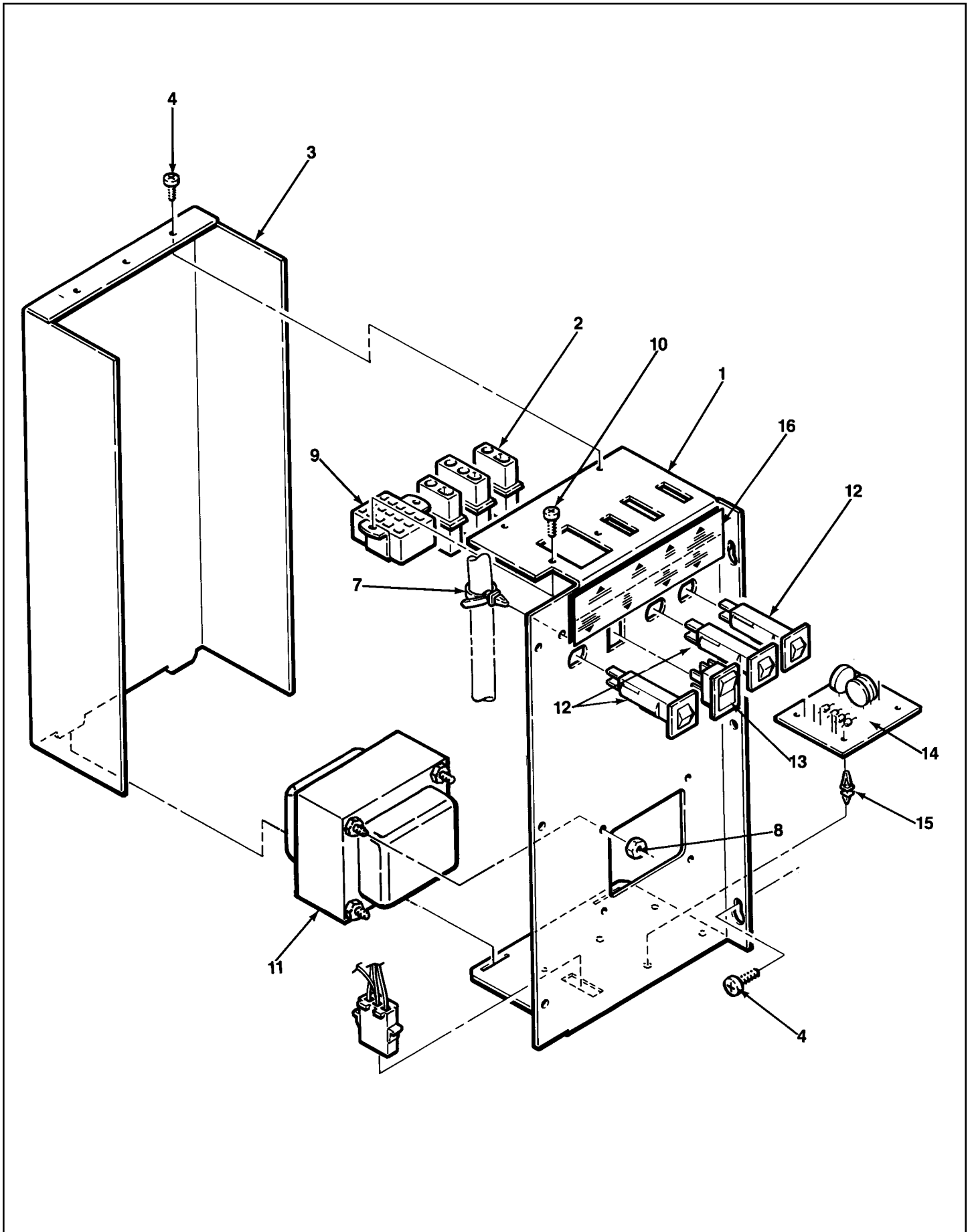

Item No.	Part No.	Description
1	660489	Assembly Complete, Junction Box. 110 Volts.
	660489-2	Assembly Complete, Junction Box. 220 Volts. Export Only.
	660489-1	Assembly Complete, Junction Box. 240 Volts. Export Only.
	660489-3	Assembly Complete. Junction Box. 115 Volt. Export. Mexico.
	202249	Junction Panel Only.
2	680511	Junction Box Harness, Domestic.
	680510	Junction Box Harness. Export Only.
3	202087	Cover, Junction Panel.
4	276-8R6	Screw, Pan Hd.Phil. Type 23 (8-32 x 3/8).
7	380291	Push Mount Cable Tie.
8	437-10	Nut, Keps,10-32.

Item No.	Part No.	Description
9	680452	Changer Harness. U.S.
	680516	Changer Harness (L+).
10	276-6R6	Screw Pan Hd.Phil. Type 23 (6-32 x 3/8).
11	360164	Transformer, Domestic.
	360167	Transformer, Export.
12	380241	Circuit Breaker.
13	380243	Switch, On/Off.
14	360109	Control Power Board. U.S. Only.
15	420095	PC Board Stand-Offs. U.S. Only.
16	460506	Decal, Breaker Identification. Domestic.
	460578	Decal, Breaker Identification. Export.
	460458-2	Not Shown. Voltage Decal 240 Volt.
	460458-1	Not Shown. Voltage Decal 220 Volt
	460535	Decal, Breaker Identification. French.

electrical harnesses

Part No.	Description
360163	Line Cord Set. U.S.
680305	Harness, Gum and Mint Shelf.
680445-1	Harness, Candy Shelf.
680446	Harness, Pastry Shelf.
660442	Cabinet Back Harness 5 Shelves.
660442-1	Cabinet Back Harness 6 Shelves.
660442-2	Cabinet Back Harness 7 Shelf.
680452	Harness, Mars Changer Hook-Up.
680542	Harness Interconnect 115.
680544	Line Cord Israel Only.
680456	Harness, Fan or Light.
680464	Assembly Lamp Harness.
680310	Harness, Operate Switch.

Part No.	Description
680355	Harness, Mars/Coince Bill Validator. Hook-Up. 24 Volt.
680457	Connector Ribbon.
680475	Harness, Mars/Coince Bill Validator. Hook-Up. 115 Volt.
680319	Harness, Mars Changer Hook up. Export Exec.
660505-2	Assy. Line Cord Australia.
660483	Assy. Complete Line Cord. Export.
660505-3	Assy. Complete. Line Cord. Israel.
680475-1	Harness, Mars Validator w/Card Reader w/ 2 pin molex
680577	Harness Printer.
680509	Harness, Board to Printer.
660505-5	Assy Complete Line Cord Multisnack

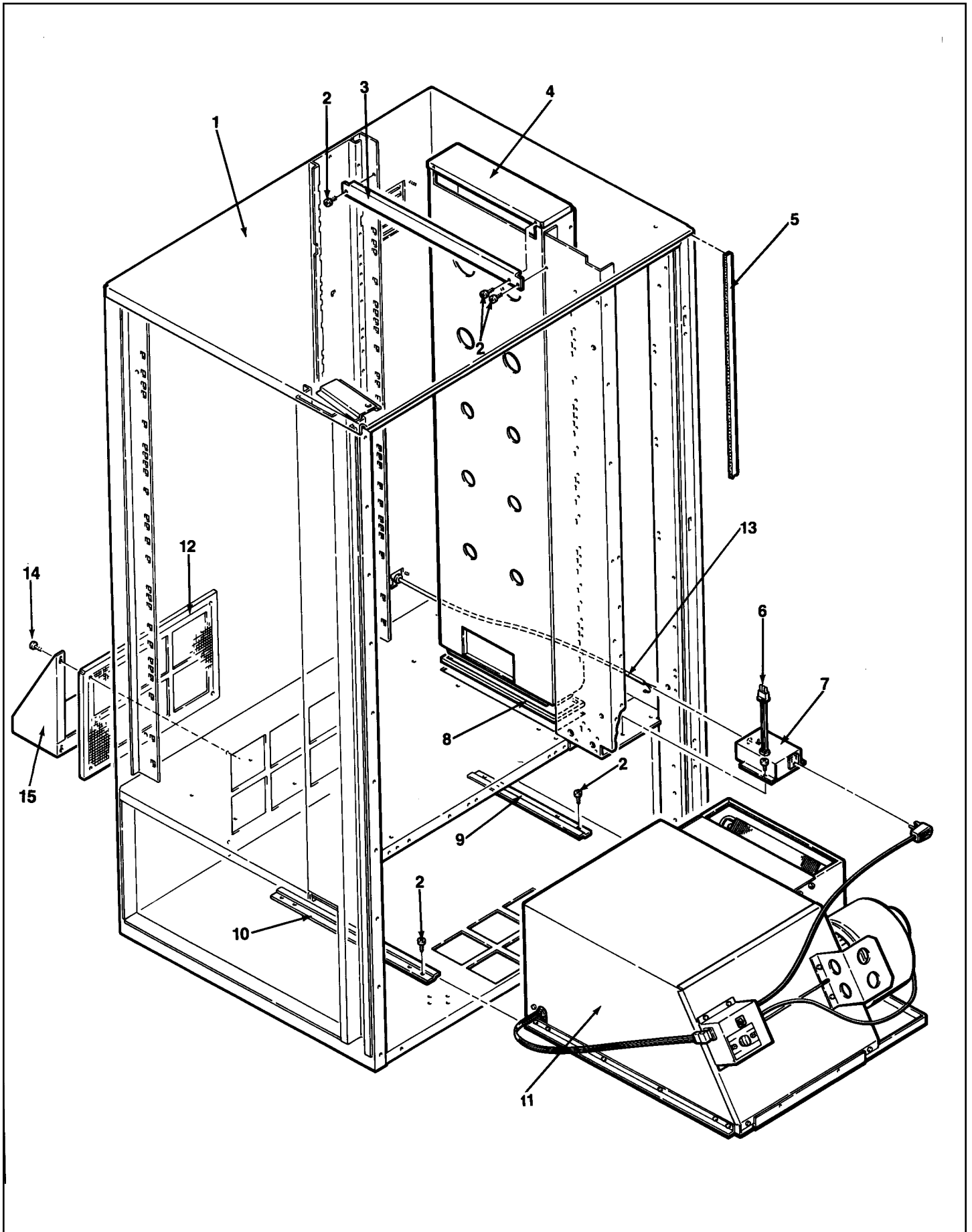

Item No.	Part No.	Description
	660451	Assembly Complete. Cabinet & Insulation Only Model 113. Specify Color.
2	276-8R6	Screw, Pan Hd.Phillips (8-32 x 3/8).
3	202404	Air Duct Top Support -113.
4	660455	Assembly, Air Duct.
5	460468	Door Gasket.Order by Inches (Qty. 80).
6	680458-1	Harness, Power Inlet Box.
	680503	Harness, Power Interlock Box.Export.
7	660447-1	Assembly Complete. Power Interconnect Box.
	660486	Assembly, Power Interconnect Box.Export.

Item No.	Part No.	Description
8	460468	Gasket. Order by Inches.
9	202145	Right Retainer.
10	202144	Left Retainer.
11	660514	Assembly Complete. Cooling Unit.115 Volt. R134A.
	660513	Assembly Complete. Cooling Unit. 220/240 Volt, Export. R134A.
12	660504	Assembly. Vent Screen.
13	660505	Assembly. Line Cord. Cooled.
14	276-8R8	Screw Pan HD Phillips (8.32X1/2)
15	202471	Deflector

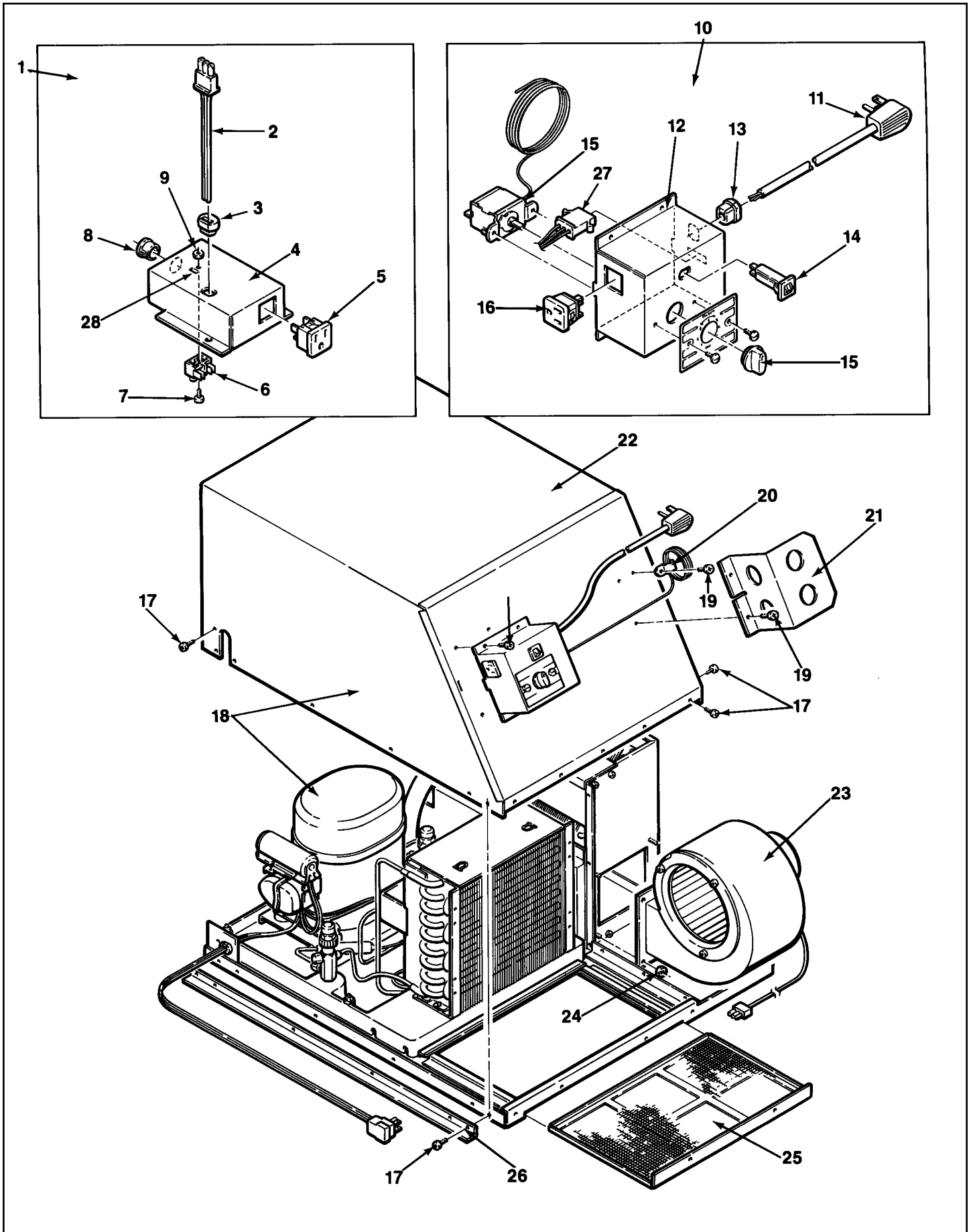

Item No.	Part No.	Description
1	660447-1 660486	Assembly Complete. Power Interconnect Box. Assembly Complete. Power Interconnect Box. Export.
2	680458-1 680503	Harness, Power Interlock Box. Harness, Power Interlock Box. Export.
3	380052-5	Strain Relief Bushing.
4	202122 202243	Power Interconnect Box Only. Power Interconnect Box. Export.
5	380252	Receptacle W/Ground. Snap in.
6	380285	Terminal Block.
7	210-8R6	Screw Rd.Hd.Phillips (#8 x 3/8).
8	420040-2 380078	Snap Bushing (1/2). Cable Tie (Not Shown).
9	404-6	Hex Nut (6-32)
10	660497 660484	Assembly Complete. Cold Control Housing. Assembly Complete.Cold Control. Export.
	460603	Decal "Press to Reset" (Not Shown)
11	680468 680504	Cold Control Cord. Cold Control Cord.Export.
12	202164 202246	Cold Control Housing Only. Cold Control Housing.Export.
13	380052-1	Strain Relief Bushing (14/3).
14	380241-1	Circuit Breaker 15 amp.

Item No.	Part No.	Description
15	360182	Cold Control Switch. Export & U.S.
16	380252	Receptacle W/Ground. Snap In.
17	276-8R6	Screw, Pan Hd., Type A, Phillips (8-32 x 3/8).
18	660514 660513	Assembly Complete. Cooling Unit 115 Volt. Assembly Complete. Cooling Unit 220/240 Volt. Export. Cooling units use 11 oz. of 134A Refrigerant (PARTS #19-21 NOT INCLUDED)
19	210-8R6	Screw Pan Hd., Type A, Phillips (#8 x 3/8).
20	420035-1	Cable Clamp (3/8).
21	202173	Guard. Cold Control.
22	660470	Assem. Comp., Condensing Cover & Insul.
23	660466-1 660466	Assembly Complete. Blower, 115 Volt. Assembly Complete. Blower 220/240 Volt. Export.
24	438-41	Keeps Nut (1/4-20).
25	600626	Assembly, Vent Screen.
26	202142 202143	Guide Angle. Left. Guide Angle. Right (Not Shown).
27	680505	Harness, Cold Control. Export.
28	440065	Insulation Mylar. (Not Shown).

AP II style

Item No.	Part No.	Description
1	340044-5	Trim, Top, For use wNinyl Insert.
2	440258-2	Insert Top Trim "Snacks".
	440285-3	Insert Top Trim "Cigarettes".
3	340057	Trim, Outside Vertical (Right or Left).
4	340058-2	Trim, Inside Vertical.(Right or Left).
5		PANEL, LEFT SIDE VERTICAL.
	202059	Presidential Walnut, Vinyl.
	202059-1	Honeytone Teak, Vinyl.
	202059-2	Painted, Specify Color.
6		PANEL RIGHT SIDE VERTICAL-LOWER.
	202061	Presidential Walnut.
	202061-1	Honeytone Teak.
	202061-2	Painted. Specify Color.
7	340058	Trim, Inside Horizontal.
8		PANEL DELIVERY TRAY.
	201356	Presidential Walnut, Vinyl.
	201356-31	Regency Walnut, Vinyl.
	201356-3	Honeytone Teak, Vinyl.
	201356-6	Painted, Specify Color.
9	340055-3	Trim, Inside Horizontal.
10		PANEL, LOWER HORIZONTAL.
	200296-36	Presidential Walnut, Vinyl.
	200296-39	Honeytone Teak Vinyl.
	200296-42	Painted, Specify Color.
11	600600	Door Only, Specify Color.
12		PANEL RIGHT SIDE VERTICAL-UPPER.
	202060	Presidential Walnut, Vinyl.
	202060-1	Honeytone Teak.Vinyl.
	202060-2	Painted. Specify Color.

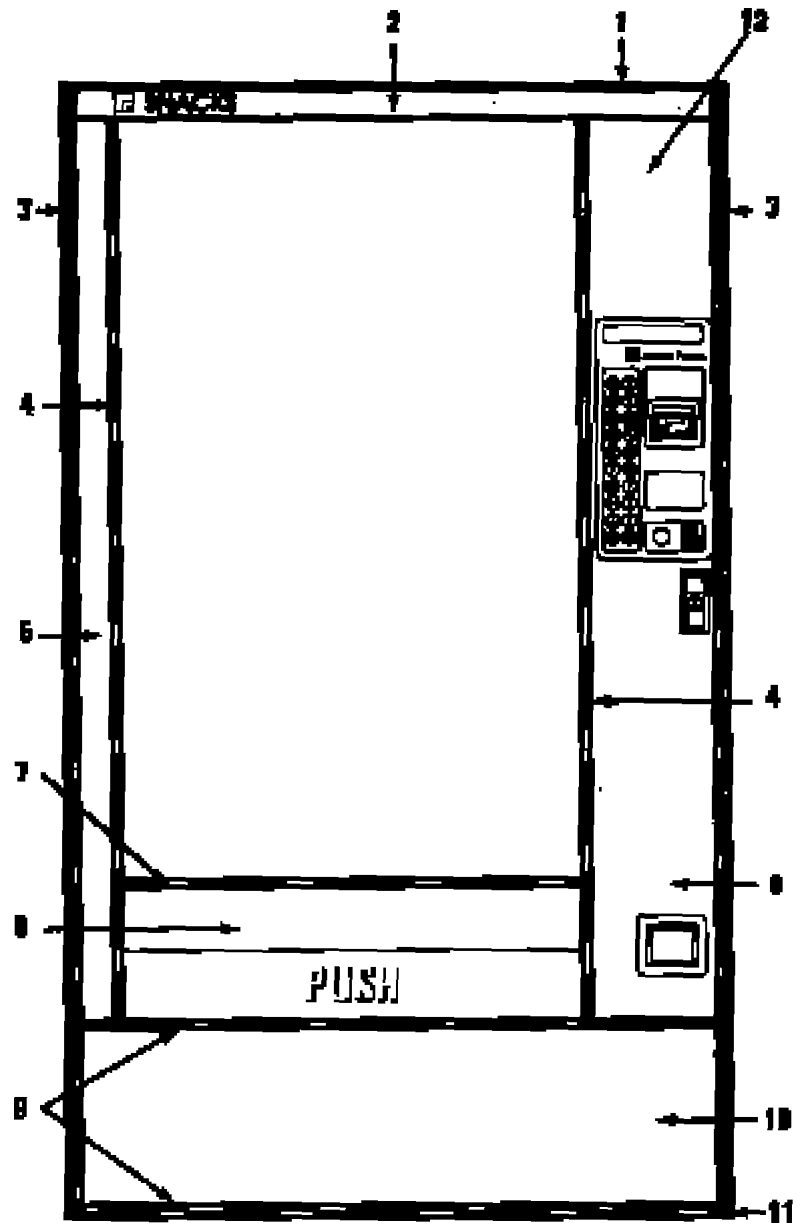

Item No.	Part No.	Description
1	660231-3	Trim, Horizontal w/Black Stripe.
2		PANEL, COVERPLATE 3".
	201417	Presidential Walnut, Vinyl.
	201417-4	Regency Walnut, vinyl.
	201417-5	Honeytone Teak, Vinyl.
	201417-6	Painted, Specify color.
	201417-21	Dove Gray.
3	340057	Trim, Outside Vertical (Right or Left).
4	340058-4	Trim, Inside Vertical (Right or Left).
5		PANEL, LEFT SIDE VERTICAL.
	202059-4	Presidential Walnut, Vinyl.
	202059-12	Regency Walnut, Vinyl.
	202059-17	Honeytone Teak, Vinyl.
	202059-6	Painted, Specify Color.
	202059-5	Port Au Prince, Vinyl.
	202059-54	Sterling Royce.
	202059-16	Dove Gray.
6		PANEL, RIGHT SIDE VERTICAL-LOWER.
	202061	Presidential Walnut, Vinyl
	202061-10	Regency Walnut, Vinyl.
	202061-1	Honeytone Teak, Vinyl.
	202061-2	Painted, Specify Color.
	202061-5	Port Au Prince, Vinyl.
	202061-44	Sterling Royce.
	202061-14	Dove Gray.
7	340058	Trim, Inside Horizontal.
8		PANEL, DELIVERY TRAY.
	201356	Presidential Walnut, Vinyl.
	201356-31	Regency Walnut, Vinyl.
	201356-3	Honeytone Teak, Vinyl.
	201356-6	Painted, Specify Color.
	201356-36	Dove Gray.
9		PANEL, LOWER HORIZONTAL.
	200296-36	Presidential Walnut, Vinyl.
	200296-37	Regency Walnut, Vinyl.
	200296-39	Honeytone Teak, Vinyl.
	200296-42	Painted, Specify Color.
	200296-9	Dove Gray.
10	600600	Door Only, Specify Color.
11		PANEL, RIGHT SIDE VERTICAL-UPPER.
	202060-4	Presidential Walnut, Vinyl
	202060-12	Regency Walnut, Vinyl.
	202060-17	Honeytone Teak, Vinyl.
	202060-5	Port Au Prince, Vinyl.
	202060-6	Painted, Specify Color.
	202060-56	Sterling Royce.
	202060-16	Dove Gray.

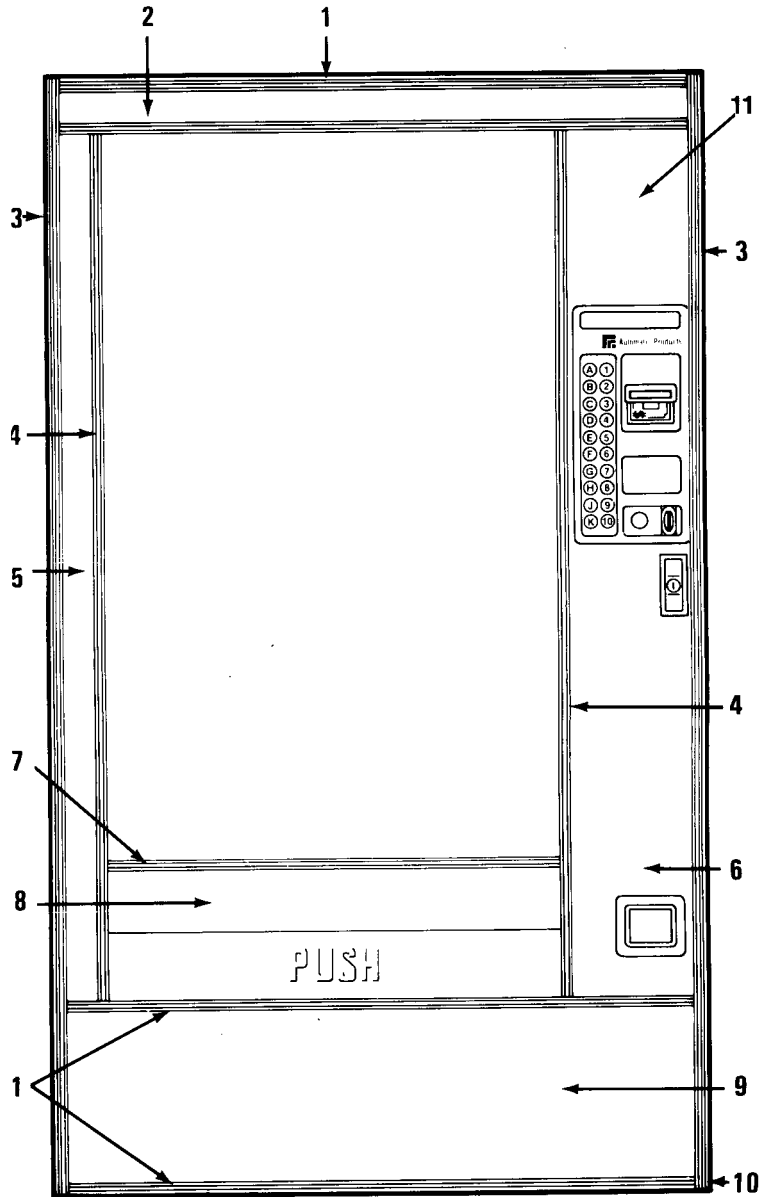

Item No.	Part No.	Description
1	340042-3	Trim, Top Only. Use only Vinyl Insert.
2	201260	Vinyl Insert, Top Trim, Sterling Royce Vinyl.
3	340057-2	Trim, Outside Vertical (Right or Left).
4	340058-7	Trim, Inside Vertical (Right or Left).
5		PANEL, LEFT SIDE VERTICAL.
	202059-9	Sterling Royce Vinyl.
6		PANEL, RIGHT SIDE VERTICAL- LOWER.
	202061-4 1	Sterling Royce Vinyl.
7	340058	Trim, Inside Horizontal.
8		PANEL, DELIVERY TRAY.
	201356-3 1	Sterling Royce Vinyl.
9	340055-3	Trim, Inside Horizontal.
10		PANEL, LOWER HORIZONTAL.
	200296-54	Sterling Royce Vinyl.
11	600600	Door Only. Specify Color.
12		PANEL, RIGHT SIDE VERTICAL-UPPER.
	202060-9	Sterling Royce Vinyl.

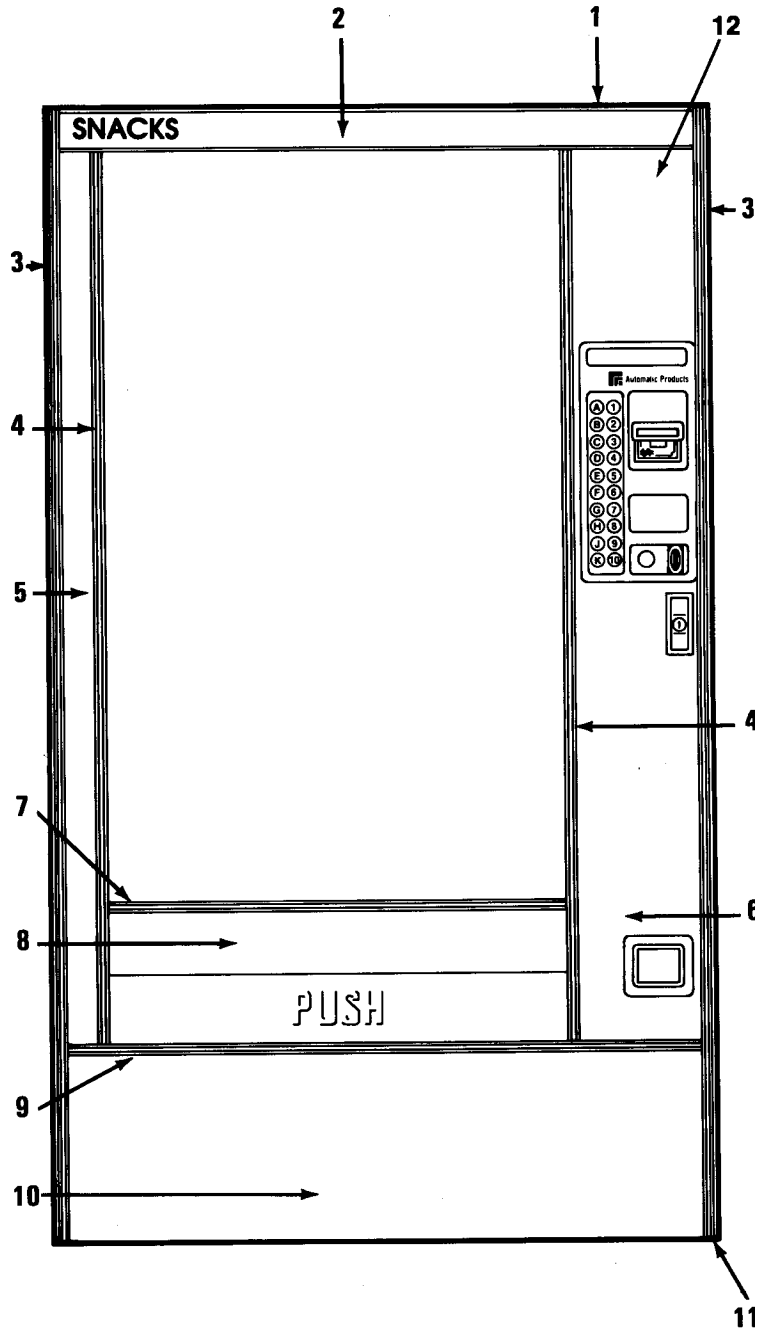

Item No.	Part No.	Description
1	340055-9	Trim Horizontal, Top & Bottom, Black.
2	201417-2	Cover Up Plate, Galvanized.
	440312-1	Top Insert, Black.
3	660231-3	Trim, Horizontal w/Black Stripe.
4	340057-2	Trim, Outside Vertical, Left or Right, Black.
5	340058-8	Trim, Inside Vertical, Left or Right, Black.
6	202059-16	L S V P Dove Gray Tron.
7	340058	Trim, Horizontal, Window.
8	201356-34	Delivery Tray Panel, Sterling Royce.
9	200296-9	Panel Lower Horizontal, Dove Gray, Tron.
10	202061-14	R S V P Dove Gray, Tron, Lower.
11	202060-16	Panel, Right Side Vertical - Upper. Dove Gray.
12	600600	Door Only. Specify Color.

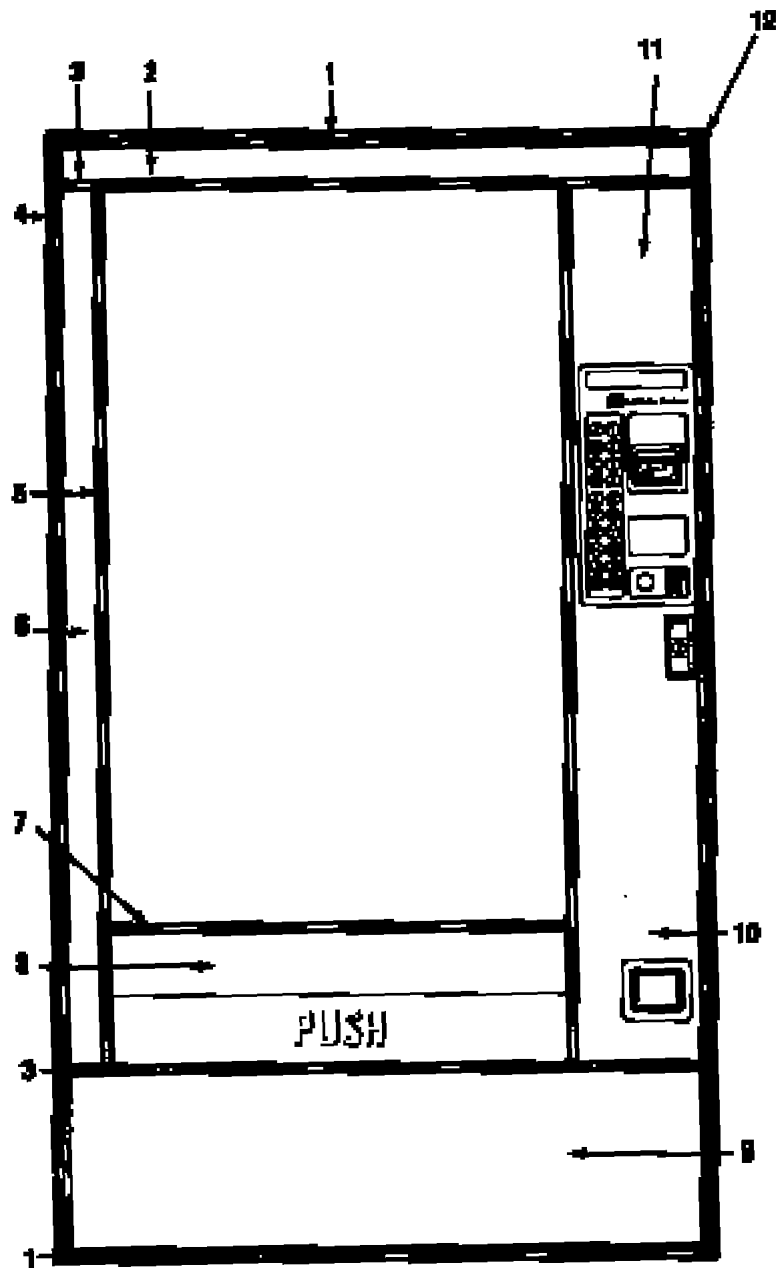

Item No.	Part No.	Description
1	340042-8	Top Trim Only.
2	200526-1	Panel, Top Trim. Black Hyde.
3	340057	Trim, Outside Vertical. Silver.
4	202059-42	Panel, Left Side Vertical. Black Hyde.
5	340058-6	Trim, Inside Vertical. Black.
6	340058-5	Trim, Horizontal Window. Black.
7	201356-3	Panel, Delivery Tray. Sterling Gray.
8	340055-9	Trim, Horizontal. Black.
9	201692-4	Panel, Lower Horizontal. Black Hyde.
	201678	Bottom Vinyl Door Edging (Not Shown).
	420186	Screw, HWH Drill Pt. Black. (6-201/2) Qty. 5.
10	202061-3	Panel, Right Side Vertical. Lower. Blk. Hyde.
11	202060-42	Panel, Right Side Vertical. Upper. Blk. Hyde.

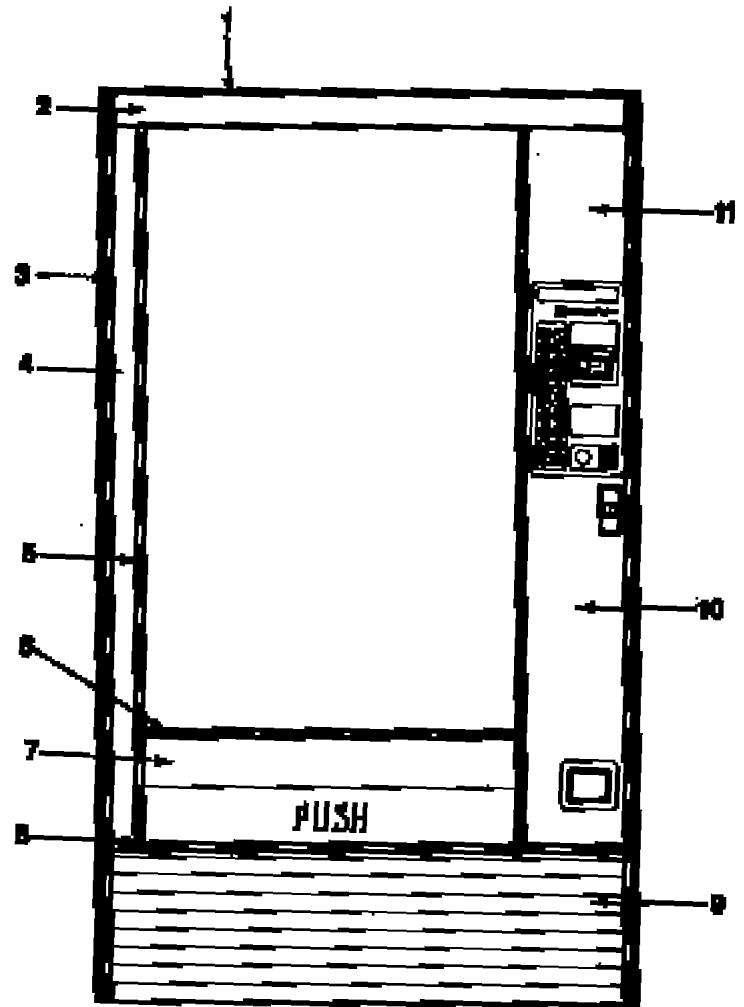



PUSH MOUNT CABLE TIE
380291



CABLE CLAMP ADHESIVE
3/4 - 420098
1/2 - 420098-1



WIRE CLAMP
420051

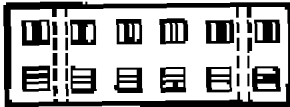

PLUG - 12 PIN
380290

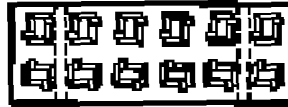

SOCKET - 12 PIN
380290



MOLEX CRIMP TERMINAL
380294

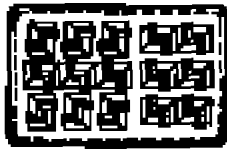

SOCKET 16 CIRCUIT
380276



MOUNTING TYPE
CABLE TIE
380078



2 PIN INTERNATIONAL MOLEX
380281



2 PIN INTERNATIONAL MOLEX
RECEPTACLE
380280



4 PIN INTERNATIONAL MOLEX PLUG
380296
3 PIN INTERNATIONAL MOLEX PLUG
FREE HANGING - 380286
PANEL MOUNT - 380286-1



4 PIN INTERNATIONAL MOLEX
RECEPTACLE
380293
3 PIN INTERNATIONAL MOLEX
RECEPTACLE
380288

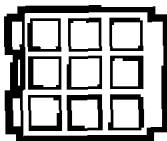

8 PIN INTERNATIONAL MOLEX
PLUG
380282



MALE MOLEX TERMINAL
SMALL .093 - 380085
LARGE .082 - 380130

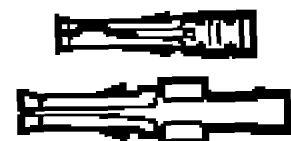

FEMALE MOLEX TERMINAL
SMALL .093 - 380084
LARGE .082 - 380129

mis printout for 110 series snack

REPORT DATE 09/23/94		COMMENTS
REPORT TIME 09:05		Special notes or Service Mode For Access in BOLD
ID101	12345678	<i>Eight digit machine ID number - Mode Service 0300</i>
EA301	6	<i>Number of electronic audits</i>
EA203	0	<i>Number of Audit Resets</i>
VA101	20.45	<i>Cash Meter, all vends - Mode Service 8</i>
VA102	38	<i>Vend Counter all vends - Mode Service 8</i>
VA202	19	<i>Counter, Test Vends - Mode Service 9</i>
VA301	3.25	<i>Cash Meter, Winner Vends - Mode Service 0100</i>
VA302	6	<i>Vend Counter, Winner Vends - Mode Service 0100C</i>
VA702	0.00	<i>Cash Meter Discount Vends - Mode Service 0800 & 0110</i>
CA306	12.45	<i>Cash to Coin Box</i>
CA308	8.00	<i>Value of Bills Accepted</i>
DA201	0.00	<i>Cash Meter, Debit Card Sales</i>
DA202	00	<i>Vend Counter, Debit Card Sales</i>
CA602	40	<i>Number of Door Openings</i>
EA1	*1*23*09:00*01	<i>Time of most recent door open (hour)</i>
		<i>*Number*Day of month*hour:OO*Duration of opening</i>
EA1	*2*23*08:00*21	<i>Time of second most recent door open</i>
EA1	*3*22*09:00*11	<i>Time of third most recent door open</i>
EA1	*4*21*09:00*15	<i>Time of fourth most recent door open</i>
PA 1	*11**A1,A3,A5,A7	<i>Product Code (* 11) and Selections assigned to that code</i>
PA202	10	<i>Vend Counter, Product Code (*11) - Mode Service 0500</i>
PA202	5.00	<i>Cash Meter, Product Code (* 111</i>
EA1	*11*23*08:00	<i>Most Recent Product Code Vend (hour)</i>
		<i>*Product Code*Day of month*hour:OO**</i>
PA1	*21**B1,B3,B5,B7	<i>Product Code (*21) and Selections assigned to that code</i>
PA202	6	<i>Vend Counter, Product Code (*21) - Mode Service 0600</i>
PA202	3.00	<i>Cash Meter, Product Code (*21)</i>
EA1	*21*23*08:00	<i>Most Recent Product Code Vend ((hour)</i>
END OF PRINTOUT`		

Note: Dotted lines added to printer tape for clarity.
 All clock dependent functions require that time & date are correctly set in Service Mode 0200.
 Revision M or higher software required. Mode Service 0501

Problem	Cause	Remedy	
No power	No lights	Check wall outlet for correct wiring, and line cord. See page 3.	
	Lights work - no power to board	Check transformer outputs & circuit breakers	
	No power to the board	Check wiring connections	
	Defective power board	Replace power board	
	Display blank		Check for voltage at P1-110 Machine-4.7 volts between yellow wires
			<i>LCM machines-24VAC at white wires at P1</i>
Won't take coins	No power to machine	Check wall outlet, line cord & voltage	
	Defective changer	Replace changer	
	Machine only accepts one coin	Machine lost its vend prices - reprice and test	
	Defective circuit breaker	Replace circuit breaker	
	No power to coin payouts	Replace power board <i>or logic board on LCM machines</i>	
Won't payout coins/incorrect change returned	No voltage	Check voltages	
	Defective power board	Replace power board	
	Defective coin mechanism.	Replace coin mechanism.	
	Jammed coins in tube	Remove coins	
Won't take bills	No coins in coin tubes	Fill coin tubes	
	Belts or stacker doesn't run on power-up	Check for 110 VDC on power board	
	Belts run-bill goes half way but won't accept	Replace validator	
	Incorrect inventory	Check inventory of coin mechanism by entering service mode 10-125	

trouble shooting chart

Problem	Cause	Remedy
Says make another selection	Motor ½ cycled	Home motor and retry / <i>LCM do mode 5 test vend</i>
	Selection lost its price	Reset prices
	Motor won't turn	Swap shelves with another shelf and retry
		Check shelf harness connection to board
	Check 24VAC to logic board (blue wires 110) / <i>white wires LCM</i>	
Display messages	"Machine use not allowed"	Machine set in shutdown mode see mode 800 in manual
	"Buy now & save X%"	Machine set in discount mode see mode 900 in manual
	"Free"	Winner vend set to 01
		Discount set on
		Selection priced at 00.00
Free vend on		
Use correct change	Coin tubes empty	Re-fill coin tubes
	Says use correct change with coin tubes full	Replace coin mechanism
Spirals turn more than one turn	Capacitor discharging current	Re-solder capacitor or replace motor
	Loose wire on motor	Repair wire
	Defective motor switch	Replace switch
	Defective control board	Replace control board
More than one motor turns together	One of the motor wires is shorting out	Check each individual motor for loose or pinched wire
	Defective control board	Replace control board
	Incorrect vend motors installed	<i>Black bodied motors for LCM</i>
		Ivory bodied motors for 110 series

Problem	Cause	Remedy
Unable to enter service mode	Check plugs on control board	Power down and remove and install connectors
	Defective changer	Replace changer
	Defective main board	Replace board
Coin mechanism jackpots	Incorrect voltage	Check voltages \pm 10%
	Defective coin mechanism	Replace coin mechanism
	Defective board	Replace control board
Motor doesn't home on door close	No voltage	Check for correct voltages
	Defective door switch	Replace door switch
	Defective board	Replace board

connector pinouts

P1 POWER IN

- 1 24 VAC HOT
- 2 KEY
- 3 24 VAC NEUTRAL
- 4 7.0 VAC HOT
- 5 7.0 VAC NEUTRAL
- 6 4.7 VAC HOT
- 7 4.7 VAC NEUTRAL
- 8 4.7 VAC CENTER TAP
- 9 24 VAC 50 Ma
- 10 24 VAC 50 Ma

P2 MOTOR DRIVE

- 1 ROW A
- 2 ROW B
- 3 ROW C
- 4 ROW D
- 5 ROW E
- 6 ROW F
- 7 ROW G
- 8 ROW H
- 9 COL 1
- 10 COL 2
- 11 COL 3
- 12 KEY
- 13 COL 4
- 14 COL 5
- 15 COL 6
- 18 COL 7
- 17 COL 8
- 18 COL 9
- 19 COL 10

P3 DISPLAY

- 1 FIL
- 2 FIL
- 3 5VDC
- 4 DOR
- 5 CT
- 6 -27VDC
- 7 DATA
- 8 CLOCK
- 9 DOR
- 10 SERIAL RES. 5VDC
- 11 SERIAL RES. SIGNAL
- 12 OPTICS GND
- 13 OPTICS RECEIVE
- 14 OPTICS TRANSMIT
- 15 OPTICS 5 VOLTS

P4 MODE KEY SWITCH

- 1 KEY SWITCH CONTROL
- 2 KEY SWITCH M/O

P5 - DOOR SWITCH

- 1 SIGNAL
- 2 GND

P6 - BILL VALIDATOR

- 1 ESCRCW HIGH
- 2 \$1 HIGH
- 3 \$2 HIGH
- 4 \$5 HIGH
- 5 ESCROW ENABLE (LOW)
- 6 \$ ENABLE
- 7 \$ ENABLE
- 8 \$ ENABLE
- 9 CREDIT
- 10 (KEY)
- 11 GND
- 12 24VAC HOT
- 13 24VAC NEUTRAL
- 14 +15 VDC
- 15 +9.75 VDC

P7 TRC-6000/6010 Series Mech

- 1 24 VDC RET NF
- 2 KEY
- 3 24 VDC HOT NF
- 4 KEY
- 5 DATA
- 6 INT
- 7 AE
- 8 MECH RESET
- 9 SEND
- 10 +5VDC
- 11 GND
- 12 .05¢ DISPENSE
- 13 .10¢ DISPENSE
- 14 .25¢ DISPENSE
- 15 \$1.00 DISPENSE

P9 - MS 1600/EUROPEAN CARD READER

- 1 REC +
- 2 REC
- 3 XMIT
- 4 GND
- 5 XMIT +
- 6 24VAC HOT
- 7 KEY
- 8 24 VAC NEUTRAL
- 9 EXACT CHANGE

P10 - RS232 SERIAL INTERFACE

- 1 RECEIVE DATA
- 2 GND
- 3 TRANSMIT DATA
- 4 KEY
- 5 GND

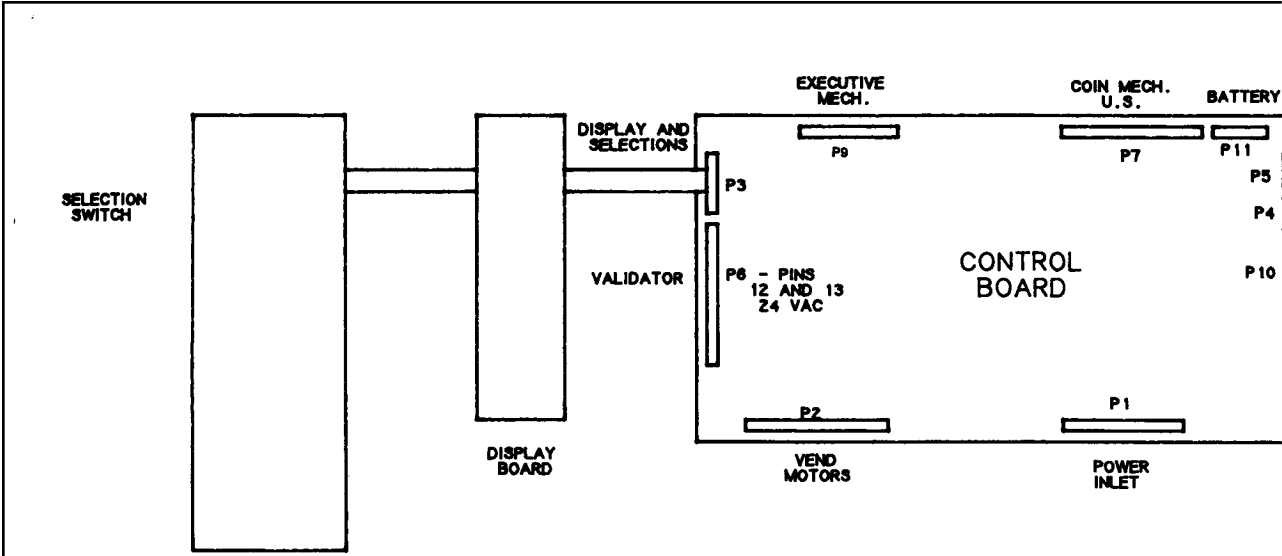

"A" COMMON ON ALL MOTORS (LARGE TERM.)

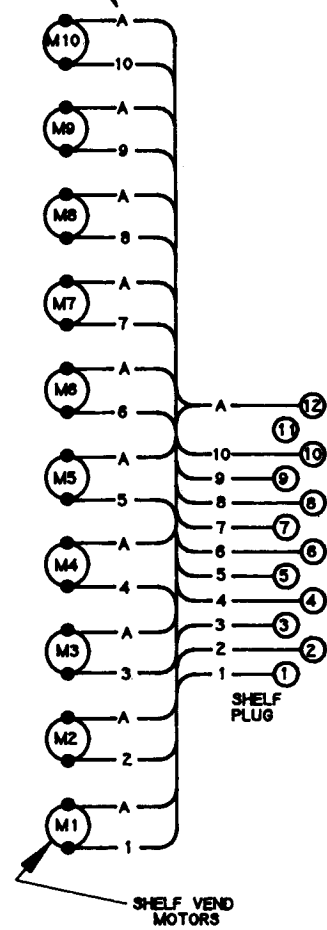

ALL SHELF SOCKETS WIRED THE SAME EXCEPT PIN NO. 12

SHELF NO.	WIRE ON PIN NO. 12
NO. 1	A
NO. 2	B
NO. 3	C
NO. 4	D
NO. 5	E
NO. 6	F

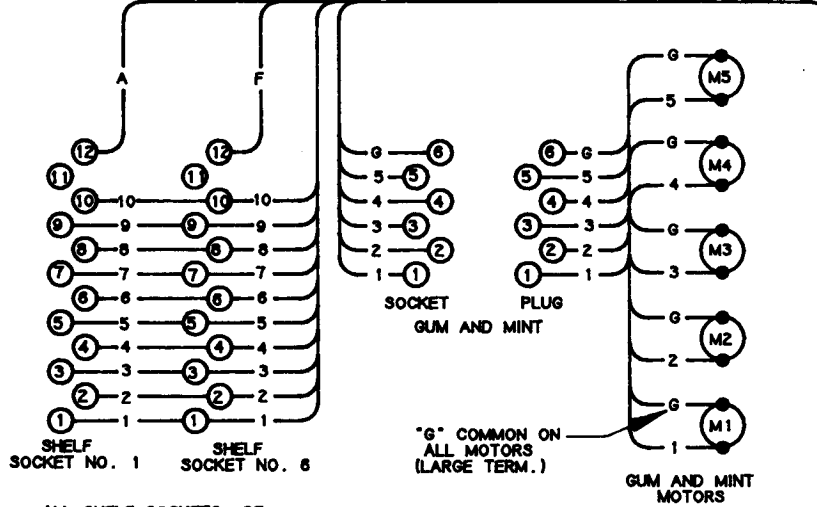
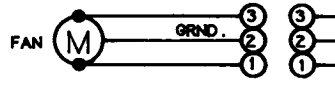

ALL SHELF SOCKETS ARE THE SAME 12 CONTACT. SOME HAVE 4, 5, 8, OR 10 MOTORS.

"G" COMMON ON ALL MOTORS (LARGE TERM.)

ALL GUM AND MINT PLUGS ARE 6 CONTACT. UNIT HAS 4 OR 5 MOTORS.

12 PIN FEMALE-)	15 PIN MALE	113676001	COIN MECH. ADAPTORS
12 PIN MALE-)	15 PIN FEMALE	113663001	MARS P/N COINCO P/N
			407049
			407048

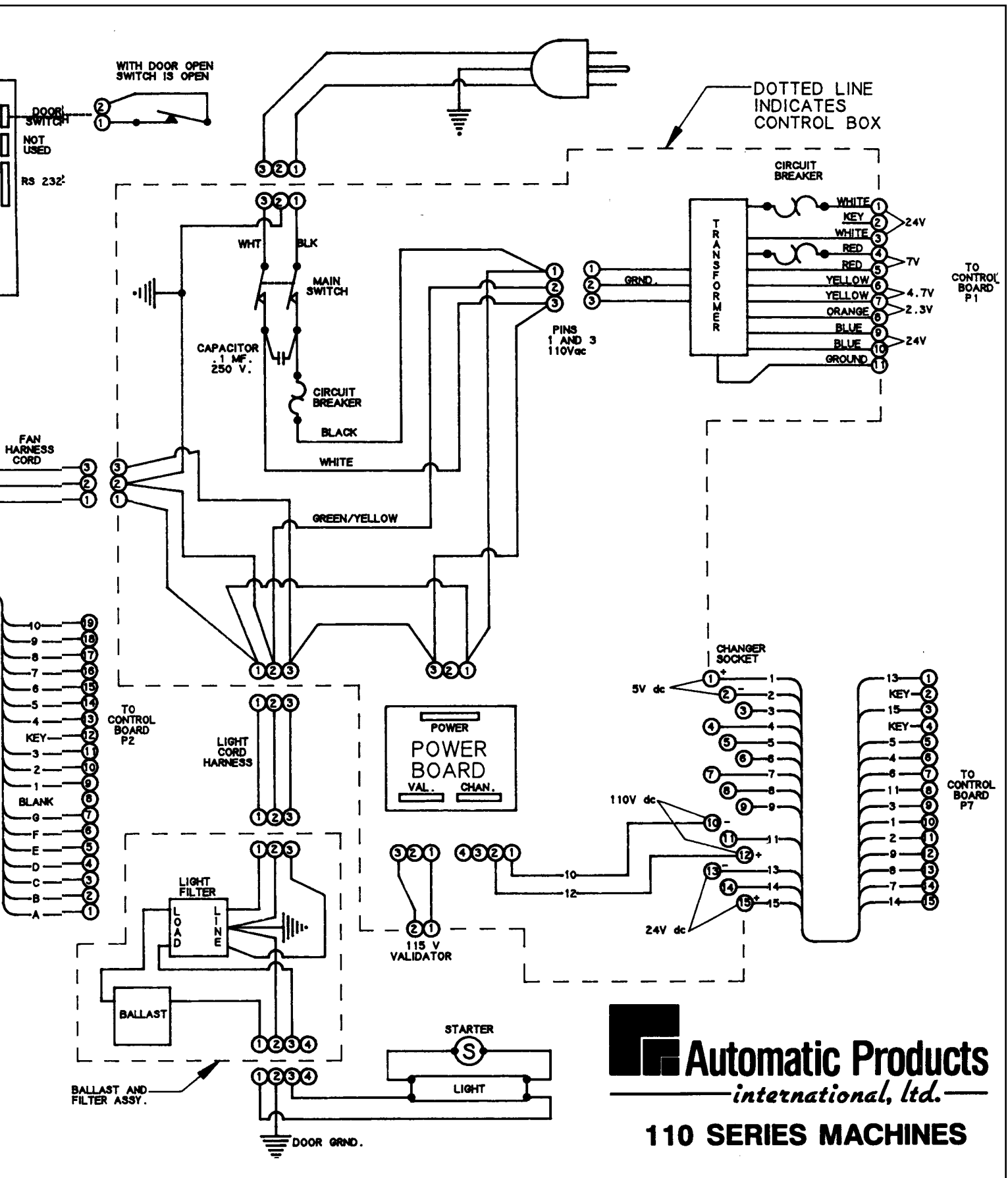

Automatic Products
international, ltd.

110 SERIES MACHINES

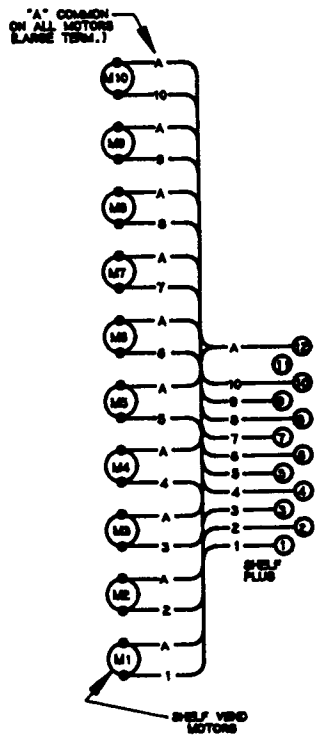
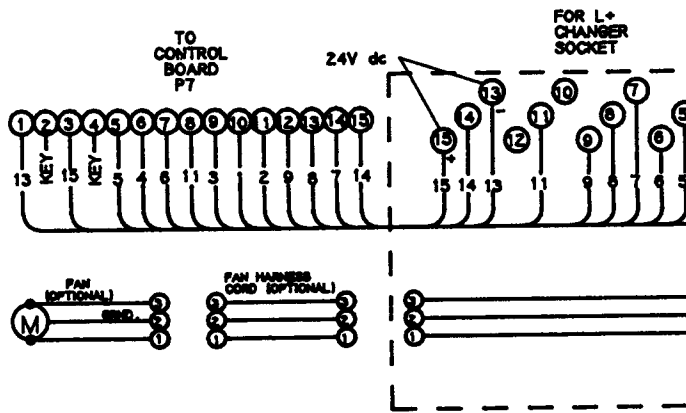
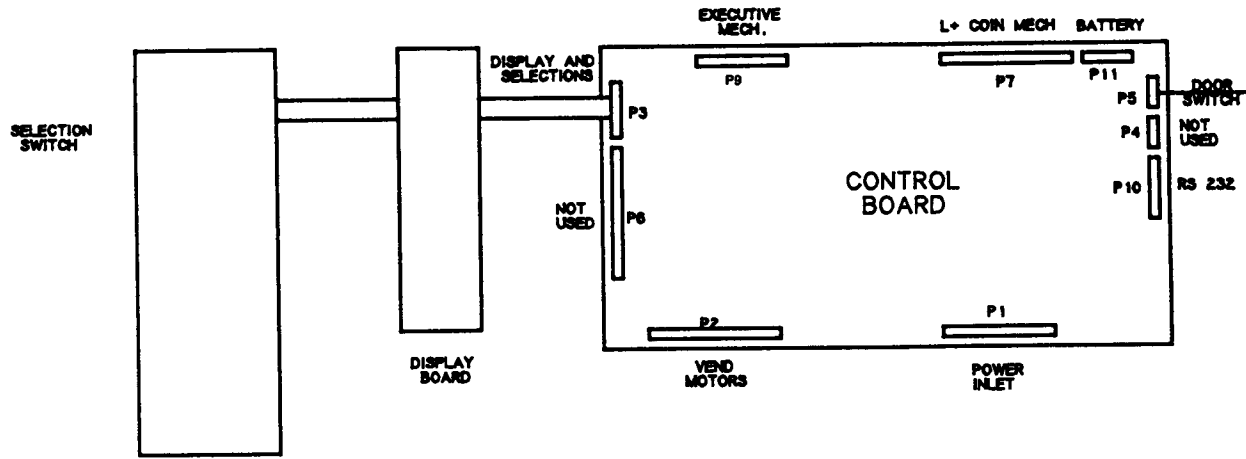

ALL SHelf SOCKETS WIRED THE SAME EXCEPT PIN NO. 12

SHelf NO.	WIRE ON PIN NO. 12
1	12
2	12
3	12
4	12
5	12
6	12
7	12
8	12
9	12
10	12
11	12
12	12

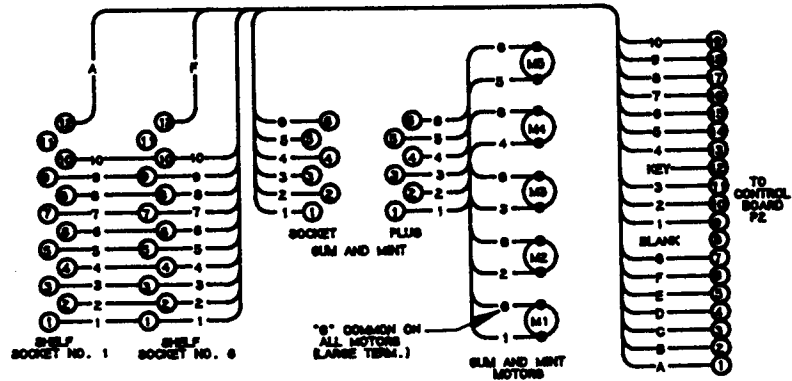

ALL SHelf SOCKETS ARE THE SAME 12 CONTACT. SOME HAVE 4, 5, 8, OR 10 MOTORS.

ALL SLM AND MNT FLUS ARE 8 CONTACT. LIST HAS 4 OR 5 MOTORS.

BALLAS FILTER

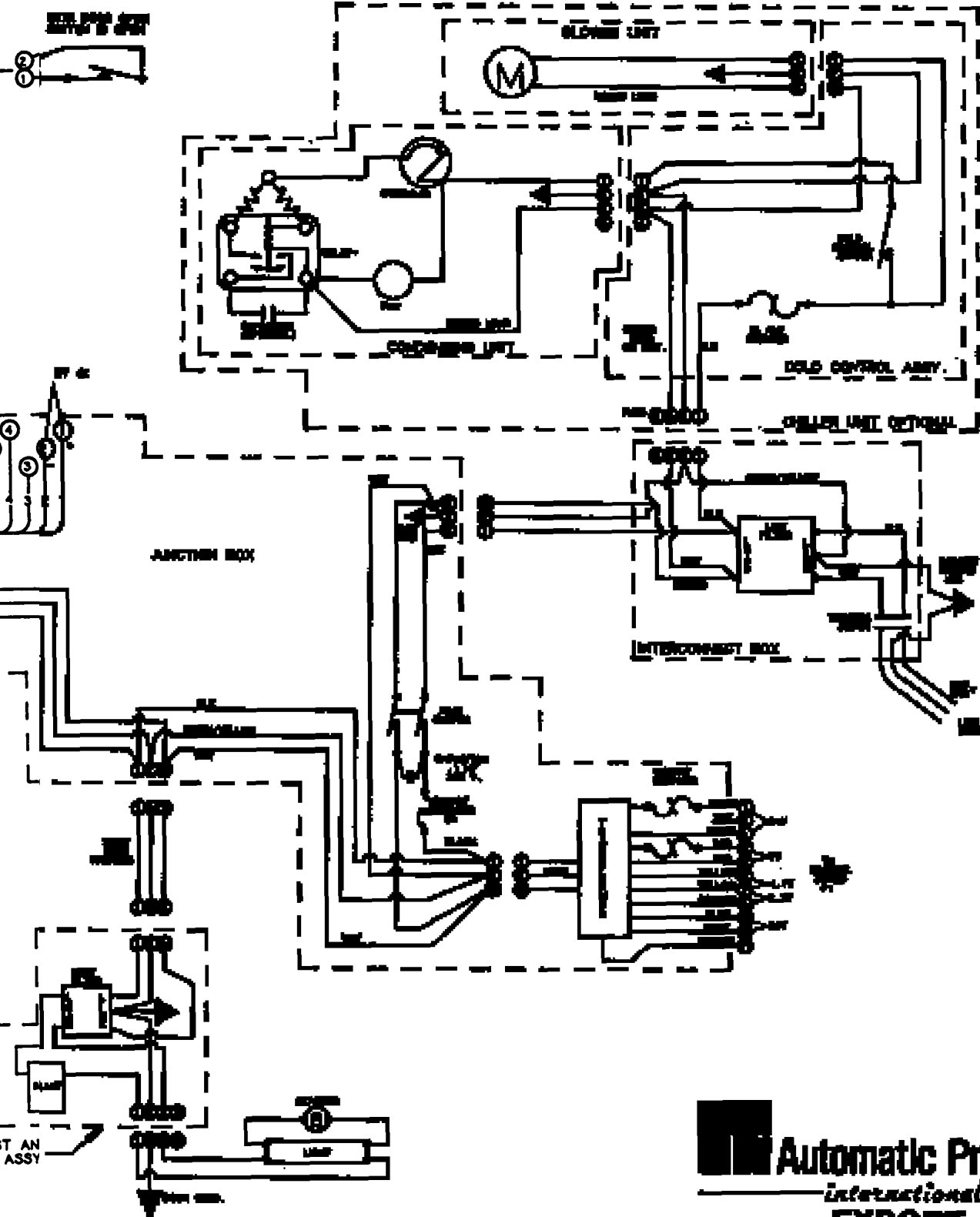

Automatic Products
International, Ltd.
EXPORT
110 SERIES MACHINES